

874 Series Fuse, Lead-free 3.6x10 mm, Fast-Acting Fuse



Agency Approvals

Agency	Agency File Number	Ampere Range
	E10480	0.100A - 10 A

Additional Information



Datasheet



Resources



Samples

Description

Single Pigtail Axial Lead 3.6 x10mm Fast-Acting Fuse

Features

- Designed to UL/CSA 248 Standard
- Single Pigtail Axial Lead format
- Fast Acting, Ceramic body fuse in a compact package
- Pb-free, RoHS Compliant
- Available in ratings of 0.10 to 10 Amperes

Applications

This space saving fuse is ideally suited for lighting, power supply, and adapter applications.

Electrical Characteristics

% of Ampere Rating	Opening Time
100%	4 hours, Minimum
200%	5 seconds, Maximum

Electrical Characteristics

Amp Code	Ampere Rating (A)	Voltage Rating (V)	Interrupting Rating	Nominal Cold Resistance (Ohms)	Nominal Melting I ² t (A ² sec)	Agency Approvals 
.100	0.100	250	50A @ 250 VAC	3.000	0.0010	x
.125	0.125	250		2.0600	0.0039	x
.200	0.200	250		0.9200	0.0066	x
.250	0.250	250		0.6580	0.030	x
.300	0.300	250		0.4350	0.039	x
.400	0.400	250		0.3655	0.0578	x
.500	0.500	250		0.2964	0.078	x
.600	0.600	250		0.2667	0.100	x
.750	0.750	250		0.2130	0.128	x
.800	0.800	250		0.1600	0.215	x
001.	1.00	250		0.0860	0.406	x
01.5	1.50	250		0.0563	0.974	x
01.6	1.60	250		0.0525	0.973	x
002.	2.00	250		0.0400	1.812	x
02.5	2.50	250		0.0329	2.675	x
3.15	3.15	250		0.0216	5.904	x
004.	4.00	250		0.0195	10.03	x
04.5	4.50	250		0.0146	14.42	x
005.	5.00	250		0.0139	14.58	x
006.	6.00	250		0.0111	23.08	x
06.3	6.30	250	0.01074	22.90	x	
06.5	6.50	250	0.0100	35.24	x	
007.	7.00	250	0.0099	36.90	x	
008.	8.00	250	0.0087	75.63	x	
010.	10.00	250	0.0066	70.10	x	

Note: Cold resistance measured at less than 10% of rated current at 23°C.

Temperature Re-rating Curve



Notes:
Re-rating depicted in this curve is in addition to the standard derating of 25% for continuous operation.

Average Time Current Curves

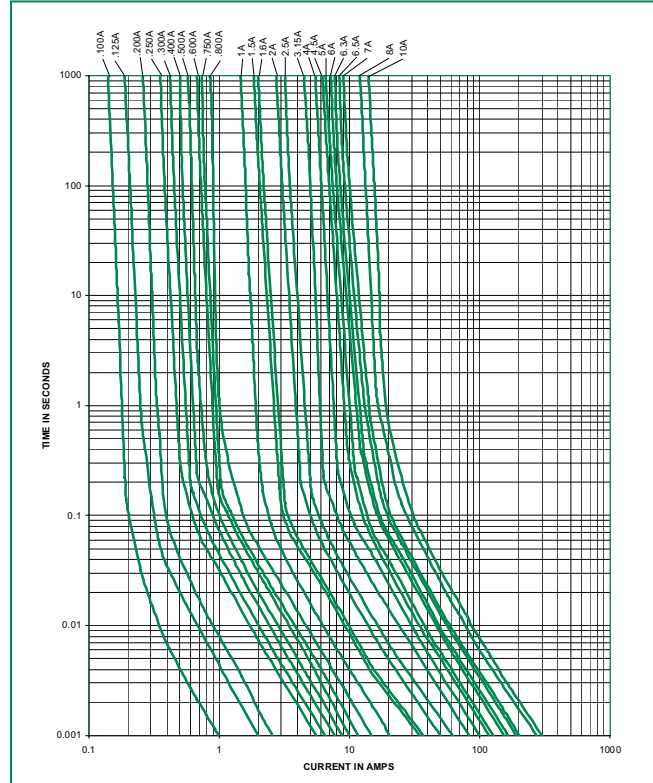

Soldering Parameters - Wave Soldering



Recommended Process Parameters:

Wave Parameter	Lead-Free Recommendation
Preheat: (Depends on Flux Activation Temperature) (Typical Industry Recommendation)	
Temperature Minimum:	100°C
Temperature Maximum:	150°C
Preheat Time:	60-180 seconds
Solder Pot Temperature:	260°C Maximum
Solder Dwell Time:	2-5 seconds

Recommended Hand-Solder Parameters:

Solder Iron Temperature: 350°C +/- 5°C
Heating Time: 5 seconds max.

Note: These devices are not recommended for IR or Convection Reflow process.

Product Characteristics

Materials	Body: Ceramic Cap: Nickel Plated Brass Tin Plated Copper
Terminal Strength	MIL-STD-202, Method 211, Test Condition A
Solderability	MIL-STD-202, Method 208
Product Marketing	Body: Brand Logo, Current Rating Characteristic "F", Agency approval marks
Packaging	Bulk (1000 pcs/pkg) Tape & Reel (1000 pcs/reel)

Operating Temperature	-55°C to 125°C
Thermal Shock	MIL-STD-202, Method 107 Test Condition B3 (5 cycles -65°C to +125°C)
Vibration	MIL-STD-202, Method 201 (10-55 Hz)
Humidity	MIL-STD-202, Method 106, High Humidity (90-98%RH), Heat (65°C)
Salt Spray	MIL-STD-202, Method 101, Test Condition B

Dimensions



All dimensions in mm

Part Numbering System

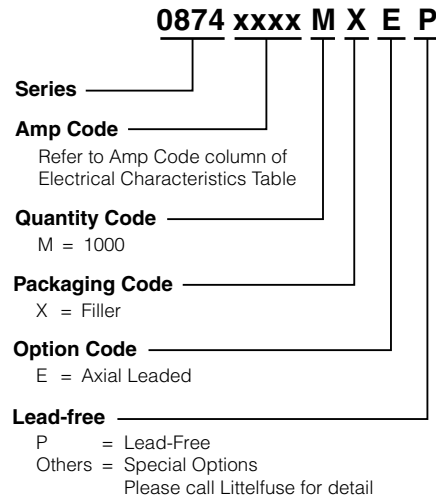

Packaging

Packaging Option	Packaging Specification	Quantity	Quantity & Packaging Code	Taping Width
874 Series				
Bulk	Bulk	1000	MXE	N/A
Tape and Reel	EIA 296	1000	MRET1	T1 = 52mm (2.062")