

# Fast Recovery Rectifier

## 1N3879 — 1N3883

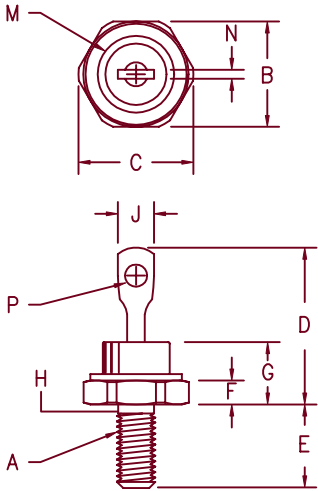

- Notes:
1. 10-32 UNF3A threads
  2. Full threads within 2 1/2 threads
  3. Standard Polarity: Stud is Cathode  
Reverse Polarity: Stud is Anode

Dim.	Inches		Millimeter		Notes
	Minimum	Maximum	Minimum	Maximum	
A	---	---	---	---	1
B	.424	.437	10.77	11.10	
C	---	.505	---	12.82	
D	---	.800	---	20.32	
E	.422	.453	10.72	11.50	
F	.075	.175	1.90	4.44	
G	---	.405	---	10.29	
H	.163	.189	4.14	4.80	2
J	---	.250	---	6.35	
M	---	.424	---	10.77	Dia.
N	.020	.065	.510	1.65	
P	.060	---	1.52	---	Dia.

### D0203AA (D04)

Microsemi Catalog Number	Working Peak Reverse Voltage	Repetitive Peak Reverse Voltage
1N3879*	50V	50V
1N3880*	100V	100V
1N3881*	200V	200V
1N3882*	300V	200V
1N3883*	400V	400V

\*Add Suffix R For Reverse Polarity

- Fast Recovery Rectifier
- 175°C Junction Temperature
- VRRM 100 to 400 Volts
- 6 Amps Current Rating

### Electrical Characteristics

Average forward current	$I_{F(AV)}$ 6 Amps	$T_C = 100^\circ\text{C}$ , Square wave, $R_{\theta JC} = 2.0^\circ\text{C/W}$
Maximum surge current	$I_{FSM}$ 200 Amps	8.3 ms, half sine $T_C = 100^\circ\text{C}$
Max peak forward voltage	$V_{FM}$ 1.40 Volts	$I_{FM} = 20\text{A}$ $T_J = 25^\circ\text{C}^*$
Max peak reverse current	$I_{RM}$ 3 mA	$V_{RRM}$ , $T_J = 150^\circ\text{C}$
Max peak reverse current	$I_{RM}$ 15 $\mu\text{A}$	$V_{RRM}$ , $T_J = 25^\circ\text{C}$
Max reverse recovery time	$t_{RR}$ 200 ns	$I_F = 1\text{A dc}$ , $V_R = 30\text{V}$ , $di/dt = 25\text{A}/\mu\text{s}$ , $T_C = 55^\circ\text{C}$
Typical junction capacitance	$C_J$ 115 pF	$V_R = 10\text{V}$ , $f = 1\text{Mhz}$ , $T_J = 25^\circ\text{C}$

\*Pulse test: Pulse width 300  $\mu\text{sec}$ , Duty cycle 2%

### Thermal and Mechanical Characteristics

Storage temp range	$T_{STG}$	-65°C to 175°C
Operating junction temp range	$T_J$	-65°C to 150°C
Max thermal resistance	$R_{\theta JC}$	2.0°C/W Junction to case
Mounting torque		12-15 inch pounds
Weight		.16 ounces (5.0 grams)

# 1N3879 — 1N3883

Figure 1  
Typical Forward Characteristics

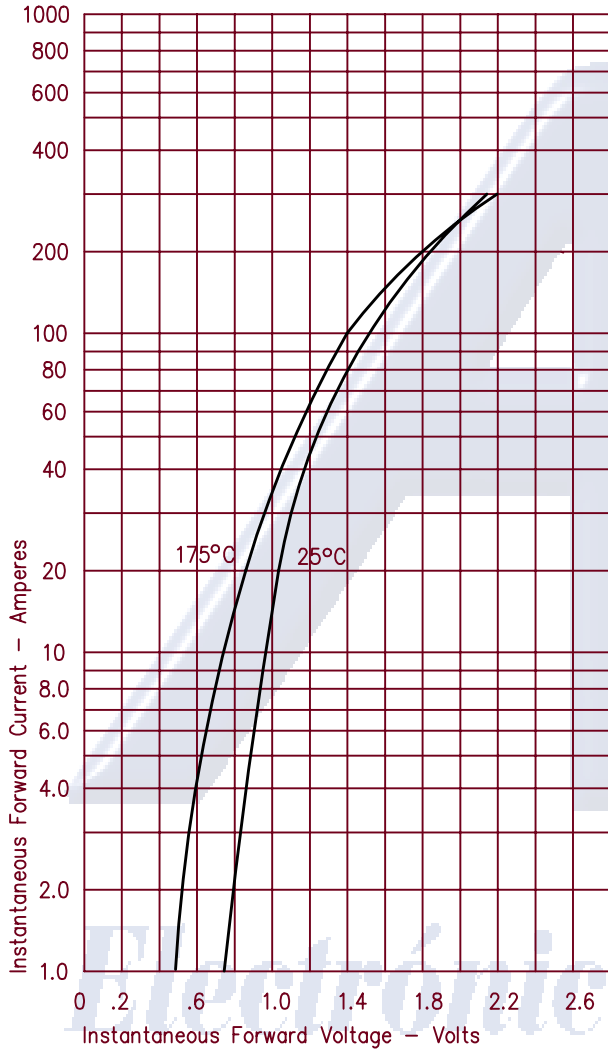

Figure 3  
Typical Junction Capacitance

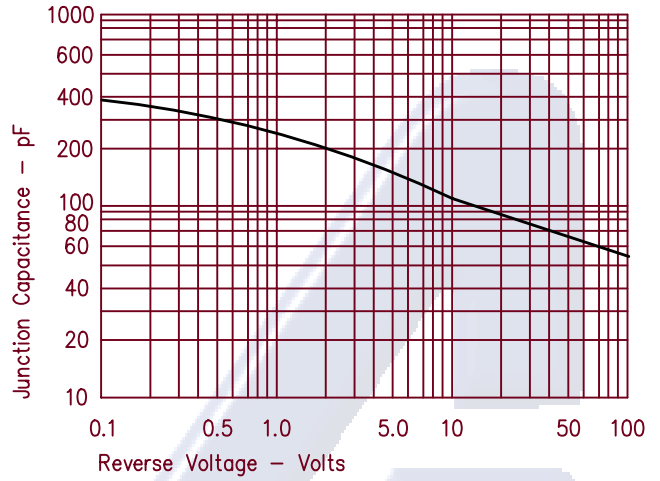

Figure 4  
Forward Current Derating

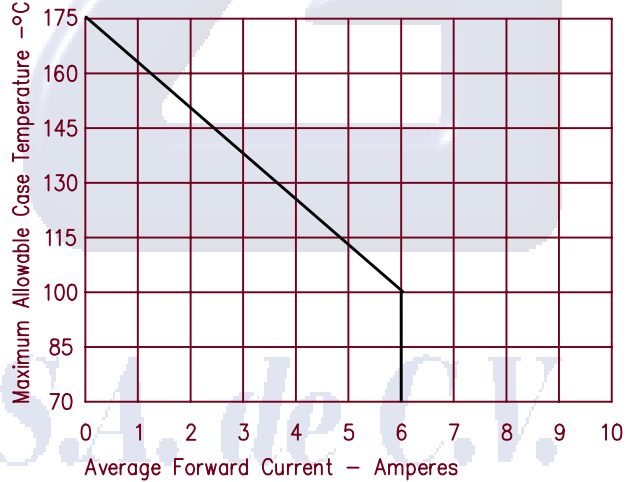

Figure 2  
Typical Reverse Characteristics

