

1.5KE6.8.....1.5KE440CA Transient Voltage Suppressor Diodes Spannungs-Begrenzer-Dioden	P_{PPM} = 1500W P_{M(AV)} = 6.5 W T_{jmax} = 175°C	V_{WM} = 5.5 ... 376 V V_{BR} = 6.8 ... 440 V
---	---	--

Version 2018-11-22

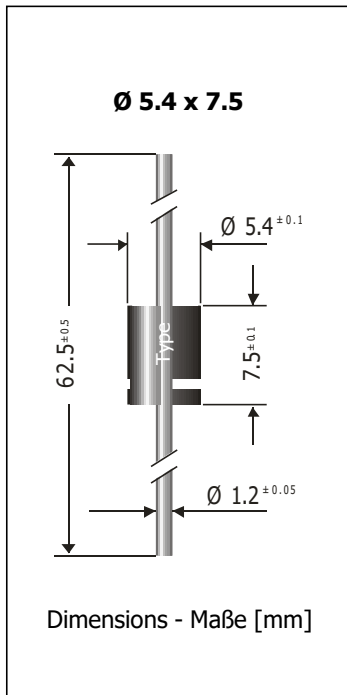

Typical Applications

- Over-voltage protection
- ESD protection
- Free-wheeling diodes
- Commercial grade
- Suffix -Q: AEC-Q101 compliant ¹⁾
- Suffix -AQ: in AEC-Q101 qualification ¹⁾

Features

- Uni- and Bidirectional versions
- Peak pulse power of 1500 W (10/1000 μs waveform)
- Very fast response time
- Compliant to RoHS, REACH, Conflict Minerals ¹⁾

Mechanical Data ¹⁾

Taped in ammo pack	1250
Weight approx.	1 g
Case material	UL 94V-0
Solder & assembly conditions	260°C/10s
	MSL N/A



Typische Anwendungen

- Schutz gegen Überspannung
- ESD-Schutz
- Freilauf-Dioden
- Standardausführung
- Suffix -Q: AEC-Q101 konform ¹⁾
- Suffix -AQ: in AEC-Q101 Qualifikation ¹⁾

Besonderheiten

- Uni- und Bidirektionale Versionen
- 1500 W Impuls-Verlustleistung (10/1000 μs Strom-Impuls)
- Sehr schnelle Ansprechzeit
- Konform zu RoHS, REACH, Konfliktmineralien ¹⁾

Mechanische Daten ¹⁾

Gegurtet in Ammo-Pack	
Gewicht ca.	1 g
Gehäusematerial	UL 94V-0
Löt- und Einbaubedingungen	260°C/10s

For bidirectional types (suffix "C" or "CA"), electrical characteristics apply in both directions.
Für bidirektionale Dioden (Suffix "C" oder "CA") gelten die elektrischen Werte in beiden Richtungen.

Maximum ratings ²⁾

Grenzwerte ²⁾

Peak pulse power dissipation (10/1000 μs waveform) Impuls-Verlustleistung (Strom-Impuls 10/1000 μs)		P _{PPM}	1500 W ³⁾
Steady state power dissipation Verlustleistung im Dauerbetrieb	T _A = 75°C	P _{M(AV)}	6.5 W ⁴⁾
Peak forward surge current Stoßstrom in Fluss-Richtung	Half sine-wave Sinus-Halbwellen 60 Hz (8.3 ms)	I _{FSM}	200 A ⁵⁾
Operating junction temperature – Sperrschichttemperatur Storage temperature – Lagerungstemperatur		T _j T _S	-50...+175°C -50...+175°C

Characteristics

Kennwerte

Max. instantaneous forward voltage Augenblickswert der Durchlass-Spannung	I _F = 25 A T _j = 25°C	V _{BR} ≤ 200 V V _{BR} > 200 V	V _F	< 3.5 V ⁵⁾ < 5.0 V ⁵⁾
Typical thermal resistance junction to ambient Typischer Wärmewiderstand Sperrschicht – Umgebung			R _{thA}	19 K/W ⁴⁾
Typical thermal resistance junction to lead Typischer Wärmewiderstand Sperrschicht – Anschlussdraht			R _{thL}	8 K/W

1 Please note the [detailed information on our website](#) or at the beginning of the data book
Bitte beachten Sie die [detaillierten Hinweise auf unserer Internetseite](#) bzw. am Anfang des Datenbuches
2 T_A = 25°C unless otherwise specified – T_A = 25°C wenn nicht anders angegeben
3 Non-repetitive pulse see curve I_{pp} = f(t) / P_{pp} = f(t)
Höchstzulässiger Spitzenwert eines einmaligen Impulses, siehe Kurve I_{pp} = f(t) / P_{pp} = f(t)
4 Valid, if leads are kept at ambient temperature at a distance of 10 mm from case
Gültig, wenn die Anschlussdrähte in 10 mm Abstand vom Gehäuse auf Umgebungstemperatur gehalten werden
5 Unidirectional diodes only – Nur für unidirektionale Dioden

Characteristics (T_j = 25°C)
Kennwerte (T_j = 25°C)

Type Typ 1.5KE...		Breakdown voltage at I _T = 1 mA Abbruch-Spannung bei I _T = 1 mA) at / bei I _T = 10 mA		Stand-off voltage Sperrspannung	Max. rev. current Max. Sperrstrom at / bei V _{WM}	Max. clamping voltage Max. Begrenzer-Spannung at / bei I _{PPM} (10/1000 μs)	
unidirectional	bidirectional	V _{BR} [V]		V _{WM} [V]	I _D [μA]	V _C [V]	I _{PPM} [A]
6.8	6.8C	6.8 ± 10%	6.12...7.48 *)	5.5	1000	10.8	145
6.8A/-AQ	6.8CA/-AQ	6.8 ± 5%	6.45...7.14 *)	5.8	1000	10.5	150
7.5	7.5C	7.5 ± 10%	6.75...8.25 *)	6.0	500	11.7	134
7.5A/-AQ	7.5CA/-AQ	7.5 ± 5%	7.13...7.88 *)	6.4	500	11.3	139
8.2	8.2C	8.2 ± 10%	7.38...9.02 *)	6.6	200	12.5	126
8.2A/-AQ	8.2CA/-AQ	8.2 ± 5%	7.79...8.61 *)	7.0	200	12.1	130
9.1	9.1C	9.1 ± 10%	8.19...10.0	7.3	50	13.8	114
9.1A/-AQ	9.1CA/-AQ	9.1 ± 5%	8.65...9.55	7.7	50	13.4	117
10	10C	10 ± 10%	9.0...11.0	8.1	10	15.0	105
10A/-AQ	10CA/-AQ	10 ± 5%	9.5...10.5	8.5	10	14.5	108
11	11C	11 ± 10%	9.9...12.1	8.9	5	16.2	97
11A/-AQ	11CA/-AQ	11 ± 5%	10.5...11.6	9.4	5	15.6	100
12	12C	12 ± 10%	10.8...13.2	9.7	5	17.3	91
12A/-AQ	12CA/-AQ	12 ± 5%	11.4...12.6	10.2	5	16.7	94
13	13C	13 ± 10%	11.7...14.3	10.5	5	19.0	82
13A/-AQ	13CA/-AQ	13 ± 5%	12.4...13.7	11.1	5	18.2	86
15	15C	15 ± 10%	13.5...16.5	12.1	5	22.0	71
15A/-AQ	15CA/-AQ	15 ± 5%	14.3...15.8	12.8	5	21.2	74
16	16C	16 ± 10%	14.4...17.6	12.9	5	23.5	67
16A/-AQ	16CA/-AQ	16 ± 5%	15.2...16.8	13.6	5	22.5	70
18	18C	18 ± 10%	16.2...19.8	14.5	5	26.5	59
18A/-AQ	18CA/-AQ	18 ± 5%	17.1...18.9	15.3	5	25.2	60
20	20C	20 ± 10%	18.0...22.0	16.2	5	29.1	54
20A/-AQ	20CA/-AQ	20 ± 5%	19.0...21.0	17.1	5	27.7	56
22	22C	22 ± 10%	19.8...24.2	17.8	5	31.9	49
22A/-AQ	22CA/-AQ	22 ± 5%	20.9...23.1	18.8	5	30.6	51
24	24C	24 ± 10%	21.6...26.4	19.4	5	34.7	45
24A/-AQ	24CA/-AQ	24 ± 5%	22.8...25.2	20.5	5	33.2	47
27	27C	27 ± 10%	24.3...29.7	21.8	5	39.1	40
27A/-AQ	27CA/-AQ	27 ± 5%	25.7...28.4	23.1	5	37.5	42
30	30C	30 ± 10%	27.0...33.0	24.3	5	43.5	36
30A/-AQ	30CA/-AQ	30 ± 5%	28.5...31.5	25.6	5	41.4	38
33	33C	33 ± 10%	29.7...36.3	26.8	5	47.7	33
33A/-AQ	33CA/-AQ	33 ± 5%	31.4...34.7	28.2	5	45.7	34
36	36C	36 ± 10%	32.4...39.6	29.1	5	52.0	30
36A/-AQ	36CA/-AQ	36 ± 5%	34.2...37.8	30.8	5	49.9	31
39	39C	39 ± 10%	35.1...42.9	31.6	5	56.4	27
39A/-AQ	39CA/-AQ	39 ± 5%	37.1...41.0	33.3	5	53.9	29
43	43C	43 ± 10%	38.7...47.3	34.8	5	61.9	25
43A/-AQ	43CA/-AQ	43 ± 5%	40.9...45.2	36.8	5	59.3	26
47	47C	47 ± 10%	42.3...51.7	38.1	5	67.8	23
47A/-AQ	47CA/-AQ	47 ± 5%	44.7...49.4	40.2	5	64.8	24
51	51C	51 ± 10%	45.9...56.1	41.3	5	73.5	21
51A/-AQ	51CA/-AQ	51 ± 5%	48.5...53.6	43.6	5	70.1	22

Characteristics (T_j = 25°C)**Kennwerte (T_j = 25°C)**

Type Typ 1.5KE...		Breakdown voltage at I _T = 1 mA Abbruch-Spannung bei I _T = 1 mA) at / bei I _T = 10 mA		Stand-off voltage Sperrspannung	Max. rev. current Max. Sperrstrom at / bei V _{WM}	Max. clamping voltage Max. Begrenzer-Spannung at / bei I _{PPM} (10/1000 μs)	
unidirectional	bidirectional	V _{BR} [V]		V _{WM} [V]	I _D [μA]	V _C [V]	I _{PPM} [A]
56	56C	56 ± 10%	50.4...61.6	45.4	5	81	19
56A/-AQ	56CA/-AQ	56 ± 5%	53.2...58.8	47.8	5	77	20
62	62C	62 ± 10%	55.8...68.8	50.2	5	89	17
62A/-AQ	62CA/-AQ	62 ± 5%	58.9...65.1	53.0	5	85	18
68	68C	68 ± 10%	61.2...74.8	55.1	5	98	16.0
68A/-AQ	68CA/-AQ	68 ± 5%	64.6...71.4	58.1	5	92	17.0
75	75C	75 ± 10%	67.5...82.5	60.7	5	108	14.0
75A/-AQ	75CA/-AQ	75 ± 5%	71.3...78.8	64.1	5	103	15.0
82	82C	82 ± 10%	73.8...90.2	66.4	5	118	13.0
82A/-AQ	82CA/-AQ	82 ± 5%	77.9...86.1	70.1	5	113	13.9
91	91C	91 ± 10%	81.9...100	73.7	5	131	12.0
91A/-AQ	91CA/-AQ	91 ± 5%	86.5...95.5	77.8	5	125	12.6
100	100C	100 ± 10%	90.0...110	81.0	5	144	10.9
100A/-AQ	100CA/-AQ	100 ± 5%	95.0...105	85.5	5	137	11.4
110	110C	110 ± 10%	99.0...121	89.2	5	158	9.9
110A/-AQ	110CA/-AQ	110 ± 5%	105...116	94.0	5	152	10.3
120	120C	120 ± 10%	108...132	97.2	5	173	9.1
120A/-AQ	120CA/-AQ	120 ± 5%	114...126	102	5	165	9.5
130	130C	130 ± 10%	117...143	105	5	187	8.4
130A/-AQ	130CA/-AQ	130 ± 5%	124...137	111	5	179	8.7
150	150C	150 ± 10%	135...165	121	5	215	7.3
150A/-AQ	150CA/-AQ	150 ± 5%	143...158	128	5	207	7.6
160	160C	160 ± 10%	144...176	130	5	230	6.8
160A/-AQ	160CA/-AQ	160 ± 5%	152...168	136	5	219	7.1
170	170C	170 ± 10%	153...187	138	5	244	6.4
170A/-AQ	170CA/-AQ	170 ± 5%	162...179	145	5	234	6.7
180	180C	180 ± 10%	162...198	146	5	258	6.1
180A/-AQ	180CA/-AQ	180 ± 5%	171...189	154	5	246	6.4
200	200C	200 ± 10%	180...220	162	5	287	5.4
200A/-AQ	200CA/-AQ	200 ± 5%	190...210	171	5	274	5.7
220	220C	220 ± 10%	198...242	175	5	344	4.5
220A	220CA	220 ± 5%	209...231	185	5	328	4.8
250	250C	250 ± 10%	225...275	202	5	360	4.3
250A	250CA	250 ± 5%	237...263	214	5	344	4.5
300	300C	300 ± 10%	270...330	243	5	430	3.6
300A	300CA	300 ± 5%	285...315	256	5	414	3.8
350	350C	335 ± 10%	315...385	284	5	504	3.1
350A	350CA	350 ± 5%	332...368	300	5	482	3.2
400	400C	400 ± 10%	360...440	324	5	574	2.7
400A	400CA	400 ± 5%	380...420	342	5	548	2.8
440	440C	440 ± 10%	396...484	356	5	631	2.4
440A	440CA	440 ± 5%	418...462	376	5	602	2.6

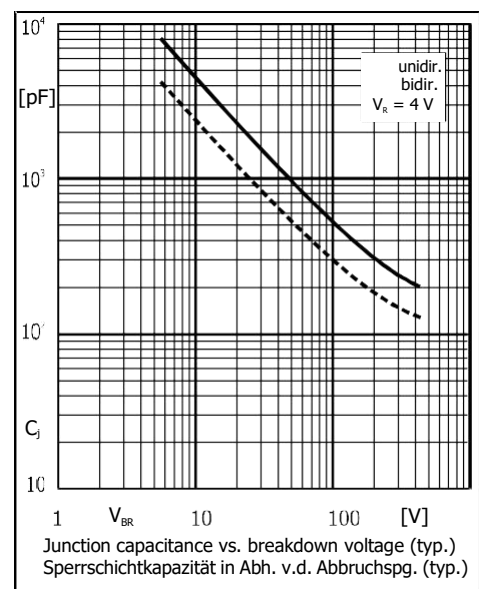
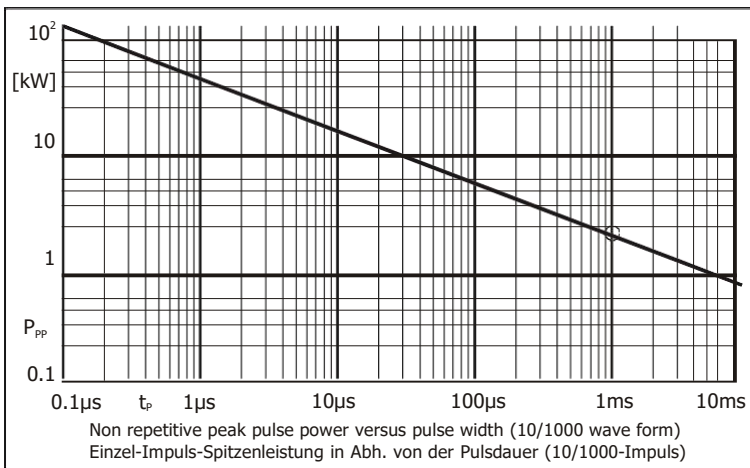
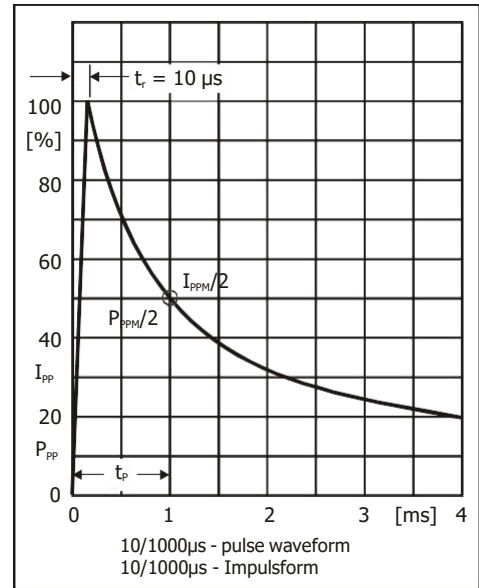
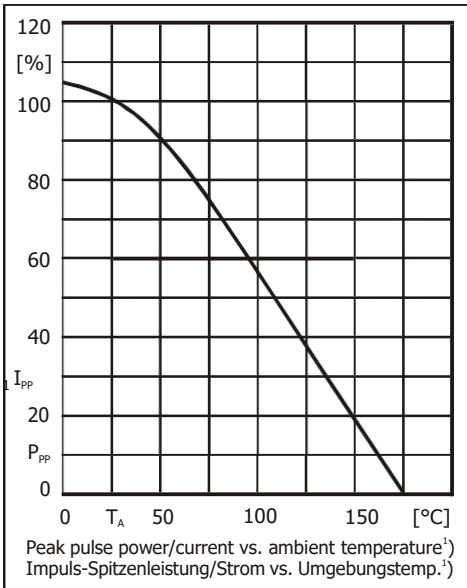

The range of type numbers is graded to the international E 24 standard. The standard tolerance of the breakdown voltage for each type is $\pm 10\%$. Suffix "A" denotes a tolerance of $\pm 5\%$ for the breakdown voltage.

e.g.: 1.5KE51C = bidirectional diode, $V_{BR} = 51 \text{ V} (\pm 10\%)$, $V_{WM} \geq 41.3 \text{ V}$ at $I_D = 5 \mu\text{A}$
1.5KE9.1A = unidirectional diode, $V_{BR} = 9.1 \text{ V} (\pm 5\%)$, $V_{WM} \geq 7.7 \text{ V}$ at $I_D = 50 \mu\text{A}$

Die Abstufung der Typen innerhalb der Reihe entspricht dem internationalen E 24-Standard. Die Toleranz der Abbruchspannung jedes einzelnen Typs beträgt in der Standardausführung $\pm 10\%$. Suffix "A" kennzeichnet eine Toleranz der Abbruchspannung von $\pm 5\%$.

Disclaimer: See data book page 2 or [website](#)
Haftungsausschluss: Siehe Datenbuch Seite 2 oder [Internet](#)

1 Valid, if leads are kept at ambient temperature at a distance of 10 mm from case
Gültig, wenn die Anschlussdrähte in 10 mm Abstand von Gehäuse auf Umgebungstemperatur gehalten werden