

Transistor

Panasonic

2SC1509

Silicon NPN epitaxial planer type

For low-frequency driver amplification

Complementary to 2SA777

Features

- High collector to emitter voltage V_{CEO} .
- Optimum for the driver stage of a low-frequency and 25 to 30W output amplifier.

Absolute Maximum Ratings (Ta=25°C)

Parameter	Symbol	Ratings	Unit
Collector to base voltage	V_{CBO}	80	V
Collector to emitter voltage	V_{CEO}	80	V
Emitter to base voltage	V_{EBO}	5	V
Peak collector current	I_{CP}	1	A
Collector current	I_C	0.5	A
Collector power dissipation	P_C	1	W
Junction temperature	T_j	150	°C
Storage temperature	T_{stg}	-55 ~ +150	°C

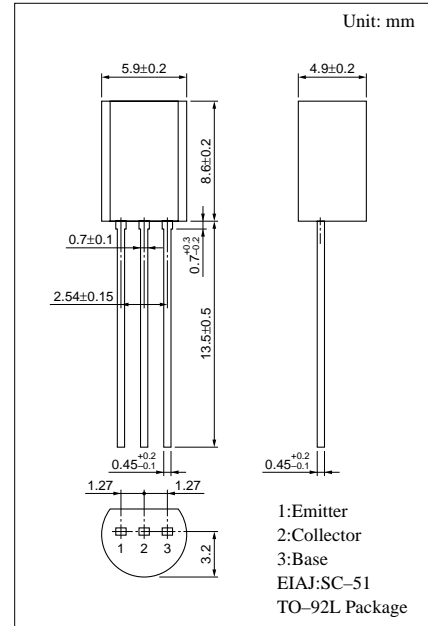

Electrical Characteristics (Ta=25°C)

Parameter	Symbol	Conditions	min	typ	max	Unit
Collector cutoff current	I_{CBO}	$V_{CB} = 20V, I_E = 0$			0.1	μA
Collector to base voltage	V_{CBO}	$I_C = 10\mu A, I_E = 0$	80			V
Collector to emitter voltage	V_{CEO}	$I_C = 100\mu A, I_B = 0$	80			V
Emitter to base voltage	V_{EBO}	$I_E = 10\mu A, I_C = 0$	5			V
Forward current transfer ratio	h_{FE1}^{*1}	$V_{CE} = 10V, I_C = 150mA^{*2}$	130		330	
	h_{FE2}	$V_{CE} = 5V, I_C = 500mA^{*2}$	50	100		
Collector to emitter saturation voltage	$V_{CE(sat)}$	$I_C = 300mA, I_B = 30mA^{*2}$		0.2	0.4	V
Base to emitter saturation voltage	$V_{BE(sat)}$	$I_C = 300mA, I_B = 30mA^{*2}$		0.85	1.2	V
Transition frequency	f_T	$V_{CB} = 10V, I_E = -50mA, f = 100MHz$		120		MHz
Collector output capacitance	C_{ob}	$V_{CB} = 10V, I_E = 0, f = 1MHz$		11	20	pF

*² Pulse measurement*¹ h_{FE1} Rank classification

Rank	R	S
h_{FE1}	130 ~ 220	185 ~ 330

Transistor

2SC1509

$P_C - T_a$

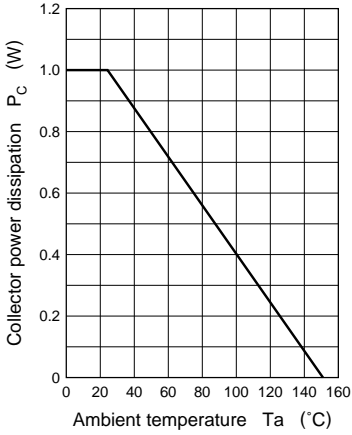

$I_C - V_{CE}$

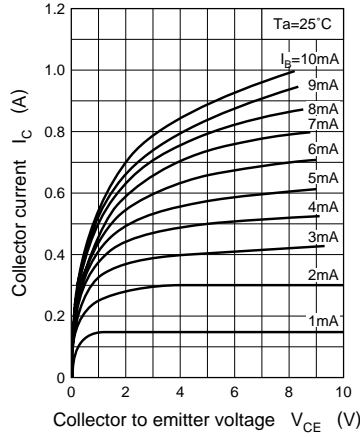

$I_C - I_B$

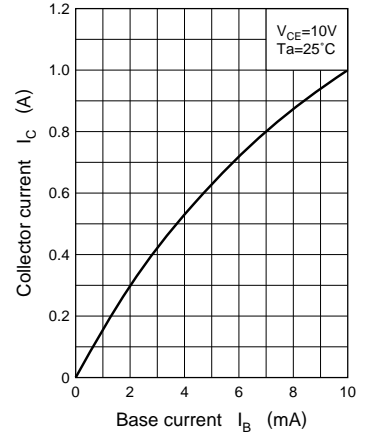

$V_{CE(sat)} - I_C$

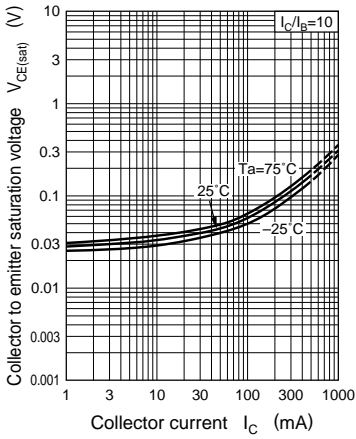

$V_{BE(sat)} - I_C$

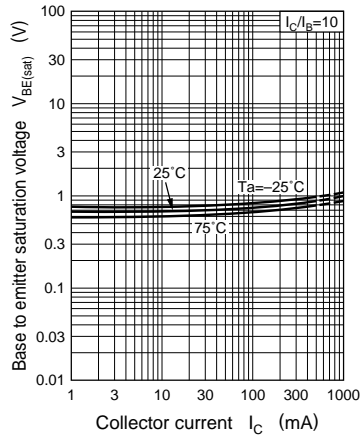

$h_{FE} - I_C$

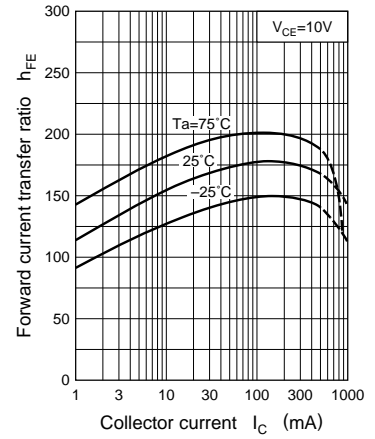

$f_T - I_E$

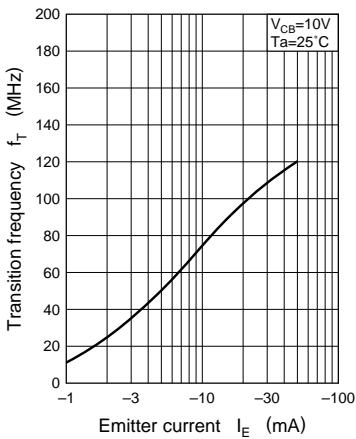

$C_{ob} - V_{CB}$

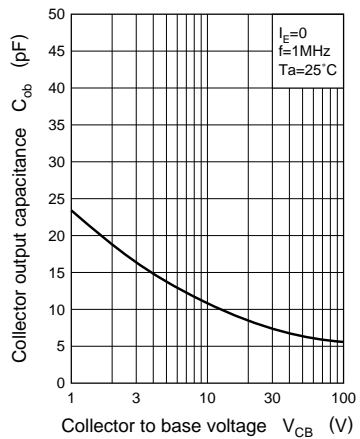

$I_{CBO} - T_a$

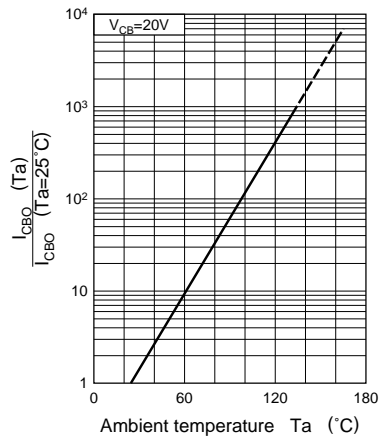

$I_{CEO} - T_a$

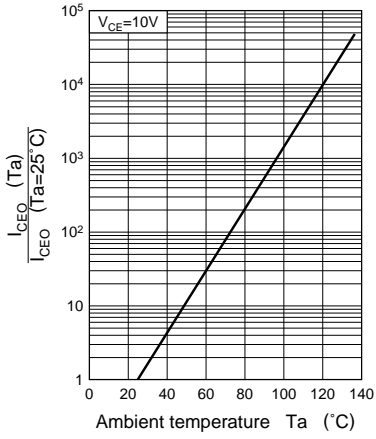

Area of safe operation (ASO)

