

2SC2705

Audio Frequency Amplifier Applications

Unit: mm

- Small collector output capacitance: $C_{ob} = 1.8 \text{ pF}$ (typ.)
- High transition frequency: $f_T = 200 \text{ MHz}$ (typ.)
- Complementary to 2SA1145.

Absolute Maximum Ratings ($T_a = 25^\circ\text{C}$)

Characteristics	Symbol	Rating	Unit
Collector-base voltage	V_{CBO}	150	V
Collector-emitter voltage	V_{CEO}	150	V
Emitter-base voltage	V_{EBO}	5	V
Collector current	I_C	50	mA
Base current	I_B	5	mA
Collector power dissipation	P_C	800	mW
Junction temperature	T_j	150	$^\circ\text{C}$
Storage temperature range	T_{stg}	-55 to 150	$^\circ\text{C}$

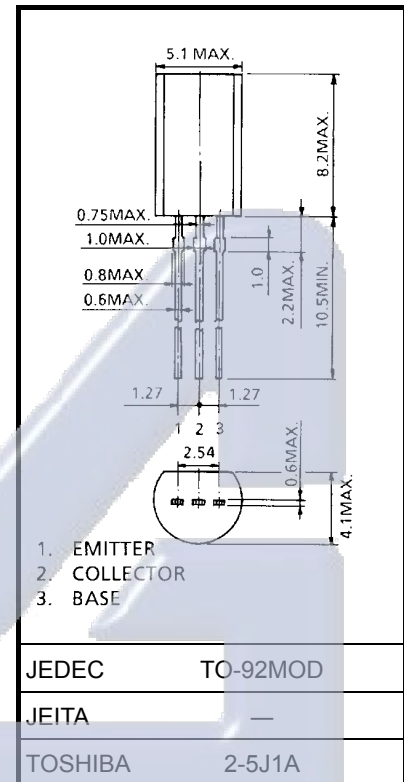

Weight: 0.36 g (typ.)

Note: Using continuously under heavy loads (e.g. the application of high temperature/current/voltage and the significant change in temperature, etc.) may cause this product to decrease in the reliability significantly even if the operating conditions (i.e. operating temperature/current/voltage, etc.) are within the absolute maximum ratings.

Please design the appropriate reliability upon reviewing the Toshiba Semiconductor Reliability Handbook ("Handling Precautions"/Derating Concept and Methods) and individual reliability data (i.e. reliability test report and estimated failure rate, etc).

Electrical Characteristics (Ta = 25°C)

Characteristics	Symbol	Test Condition	Min	Typ.	Max	Unit
Collector cut-off current	I_{CBO}	$V_{CB} = 150\text{ V}, I_E = 0$	—	—	0.1	μA
Emitter cut-off current	I_{EBO}	$V_{EB} = 5\text{ V}, I_C = 0$	—	—	0.1	μA
Collector-emitter breakdown voltage	$V_{(BR) CEO}$	$I_C = 1\text{ mA}, I_B = 0$	150	—	—	V
DC current gain	h_{FE} (Note)	$V_{CE} = 5\text{ V}, I_C = 10\text{ mA}$	80	—	240	
Collector-emitter saturation voltage	$V_{CE(sat)}$	$I_C = 10\text{ mA}, I_B = 1\text{ mA}$	—	—	1.0	V
Base-emitter voltage	$V_{BE(sat)}$	$V_{CE} = 5\text{ V}, I_C = 10\text{ mA}$	—	—	0.8	V
Transition frequency	f_T	$V_{CE} = 5\text{ V}, I_C = 10\text{ mA}$	—	200	—	MHz
Collector output capacitance	C_{ob}	$V_{CB} = 10\text{ V}, I_E = 0, f = 1\text{ MHz}$	—	1.8	—	pF

Note: h_{FE} classification O: 80 to 160, Y: 120 to 240

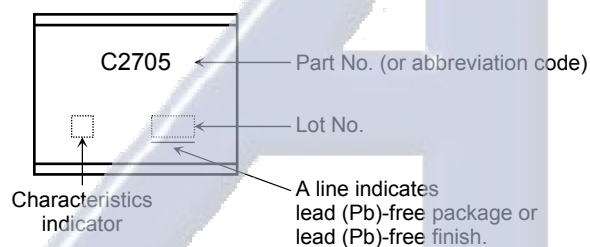
Marking

Electrónica S.A. de C.V.

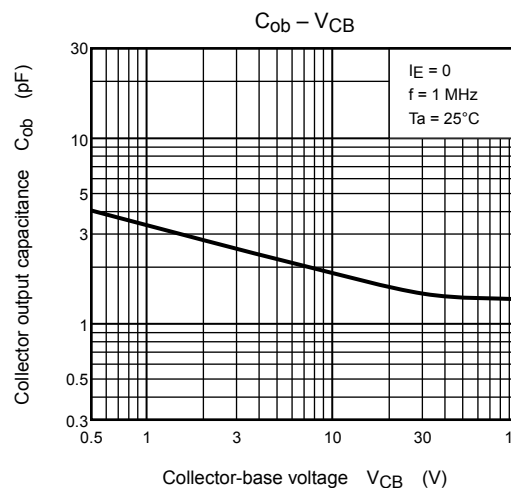
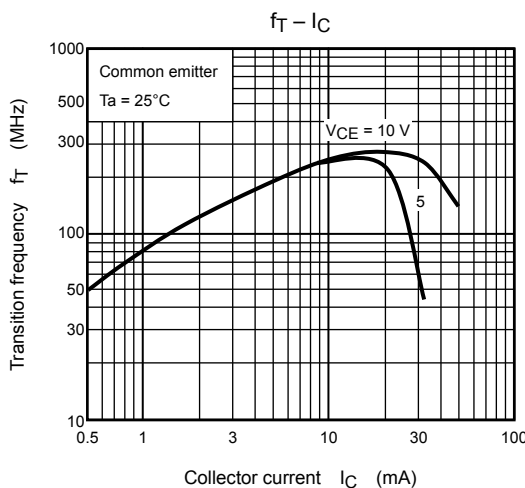
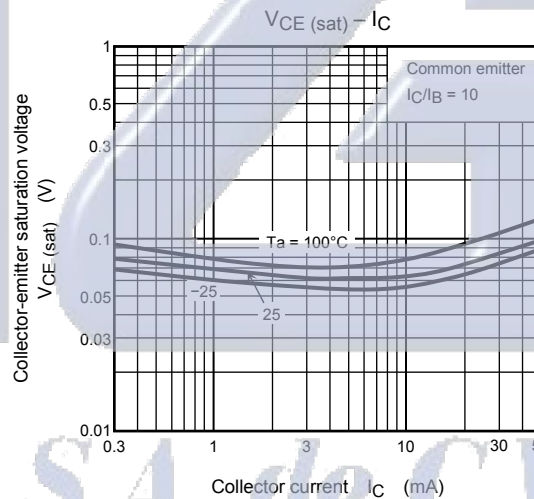
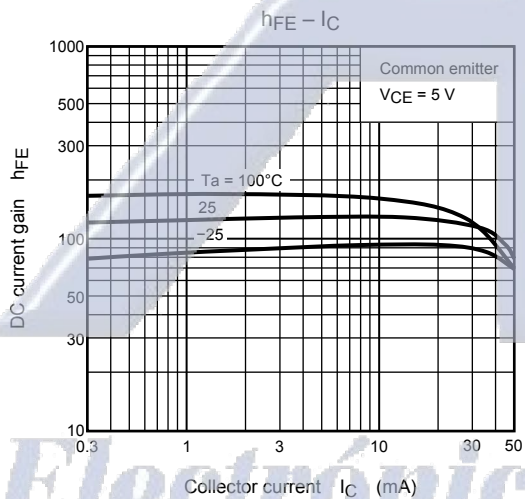
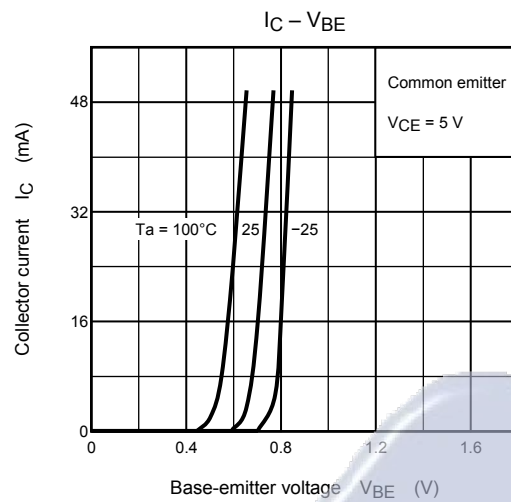
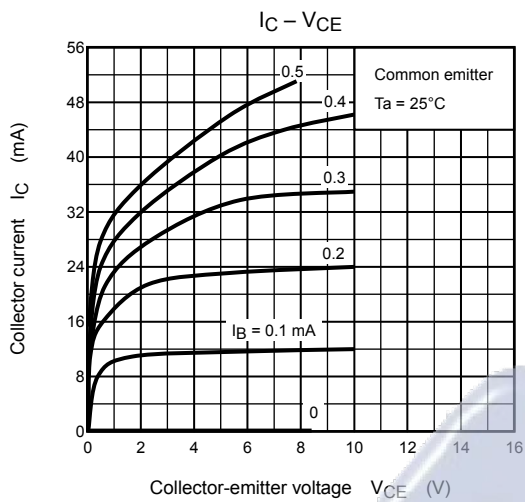

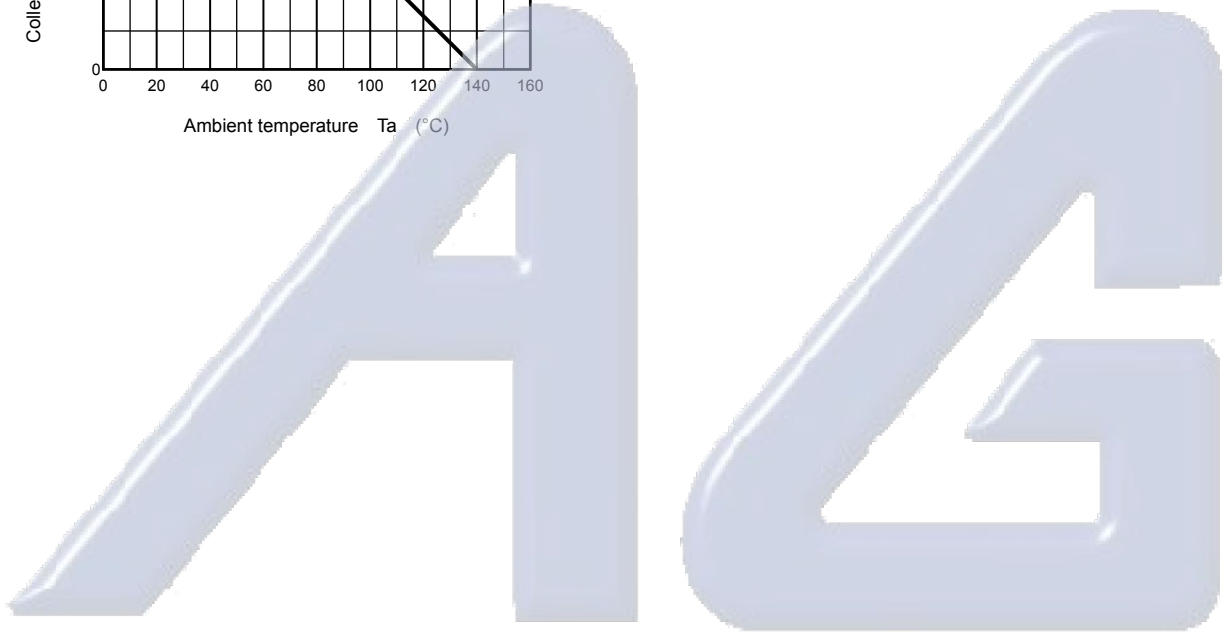
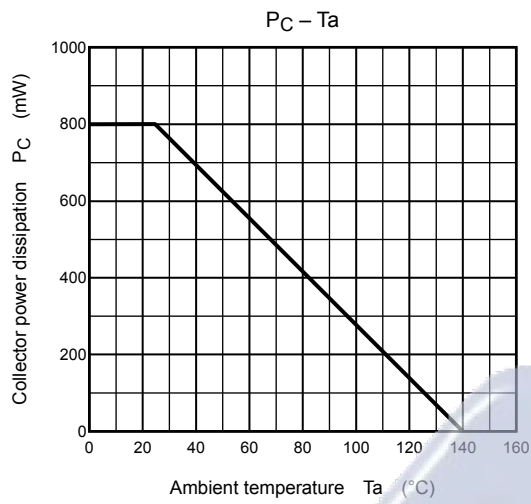

Electrónica S.A. de C.V.