

isc Silicon NPN Power Transistor

2SD856

DESCRIPTION

- Collector-Emitter Breakdown Voltage-
: $V_{(BR)CEO} = 60V(\text{Min})$
- Good Linearity of h_{FE}
- Wide Area of Safe Operation
- Complement to Type 2SB761

APPLICATIONS

- Designed for AF power amplifier applications.

ABSOLUTE MAXIMUM RATINGS($T_a=25^\circ\text{C}$)

SYMBOL	PARAMETER	VALUE	UNIT
V_{CBO}	Collector-Base Voltage	60	V
V_{CEO}	Collector-Emitter Voltage	60	V
V_{EBO}	Emitter-Base Voltage	6	V
I_C	Collector Current-Continuous	3	A
I_{CM}	Collector Current-Peak	5	A
P_C	Collector Power Dissipation @ $T_C=25^\circ\text{C}$	35	W
T_J	Junction Temperature	150	$^\circ\text{C}$
T_{stg}	Storage Temperature Range	-55~150	$^\circ\text{C}$

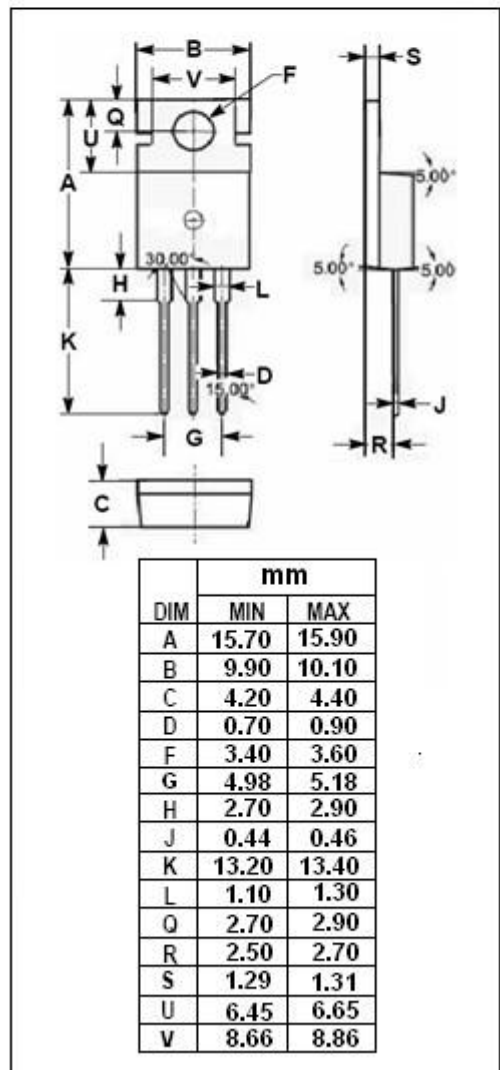
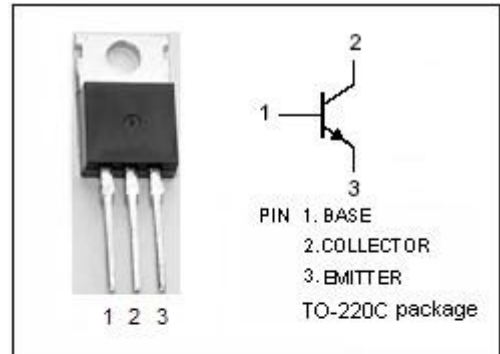

ISC Silicon NPN Power Transistor

2SD856

ELECTRICAL CHARACTERISTICS

T_C=25°C unless otherwise specified

SYMBOL	PARAMETER	CONDITIONS	MIN	TY P.	MAX	UNIT
V _{(BR)CEO}	Collector-Emitter Breakdown Voltage	I _C = 30mA; I _B = 0	60			V
V _{CE(sat)}	Collector-Emitter Saturation Voltage	I _C = 3A; I _B = 0.375A			1.2	V
V _{BE(on)}	Base-Emitter On Voltage	I _C = 3A; V _{CE} = 4V			1.8	V
I _{CEO}	Collector Cutoff Current	V _{CE} = 30V; I _B = 0			300	μA
I _{CES}	Collector Cutoff Current	V _{CE} = 60V; V _{BE} = 0			200	μA
I _{EBO}	Emitter Cutoff Current	V _{EB} = 6V; I _C = 0			1	mA
h _{FE-1}	DC Current Gain	I _C = 1A; V _{CE} = 4V	40		250	
h _{FE-2}	DC Current Gain	I _C = 3A; V _{CE} = 4V	10			

Switching Times

t _{on}	Turn-On Time	I _C = 1A; I _{B1} = -I _{B2} = 0.1A		0.5		μs
t _{off}	Turn-Off Time			3.0		μs

◆ **h_{FE-1} Classifications**

R	Q	P
40-90	70-150	120-250