

2SD869

SILICON NPN TRIPLE DIFFUSED MESA TYPE

COLOR TV HORIZONTAL OUTPUT APPLICATIONS.

FEATURES:

- High Voltage : $V_{CBO}=1500V$
- Low Saturation Voltage
: $V_{CE(sat)}=5V$ (Typ.) ($I_C=3A, I_B=0.8A$)
- High Speed : $t_f=1.0\mu s$ (Max.)
($I_{CP}=3A, I_{B1(end)}=0.8A$)
- Built-in Damper Type.
- Glass Passivated Collector-Base Junction.

MAXIMUM RATINGS ($T_a=25^\circ C$)

CHARACTERISTIC	SYMBOL	RATING	UNIT
Collector-Base Voltage	V_{CBO}	1500	V
Collector-Emitter Voltage	V_{CEO}	600	V
Emitter-Base Voltage	V_{EBO}	5	V
Collector Current	I_C	3.5	A
Emitter Current	I_E	-3.5	A
Collector Power Dissipation ($T_c=25^\circ C$)	P_C	50	W
Junction Temperature	T_j	150	$^\circ C$
Storage Temperature Range	T_{stg}	-65~150	$^\circ C$

EQUIVALENT CIRCUIT

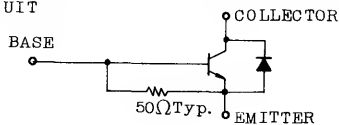

INDUSTRIAL APPLICATIONS

Unit in mm

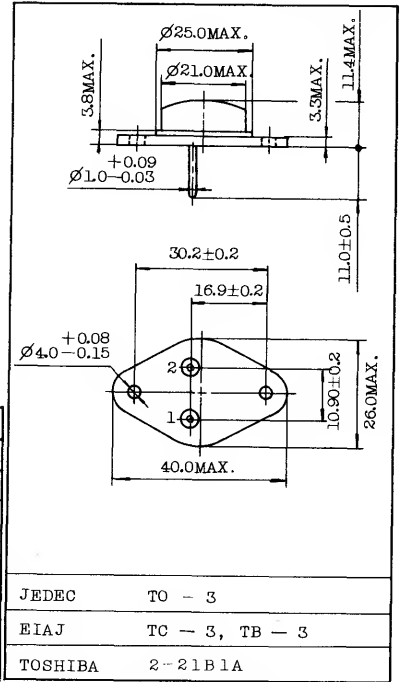

Mounting Kit No. AC42C
Weight : 17g

ELECTRICAL CHARACTERISTICS ($T_a=25^\circ C$)

CHARACTERISTIC	SYMBOL	TEST CONDITION	MIN.	TYP.	MAX.	UNIT
Collector Cut-off Current	I_{CBO}	$V_{CB}=500V, I_E=0$	-	-	10	μA
Emitter-Base Breakdown Voltage	$V_{(BR)EBO}$	$I_E=200mA, I_C=0$	5	-	-	V
DC Current Gain	h_{FE}	$V_{CE}=5V, I_C=0.5A$	8	12	-	
Collector-Emitter Saturation Voltage	$V_{CE(sat)}$	$I_C=3A, I_B=0.8A$	-	5	8	V
Base-Emitter Saturation Voltage	$V_{BE(sat)}$	$I_C=3A, I_B=0.8A$	-	-	1.5	V
Forward Voltage(Damper Diode)	$-V_F$	$I_F=3.5A$	-	1.6	2.0	V
Transition Frequency	f_T	$V_{CE}=10V, I_C=0.1A$	-	3	-	MHz
Collector Output Capacitance	C_{ob}	$V_{CB}=10V, I_E=0, f=1MHz$	-	95	-	pF
Fall Time (Fig.)	t_f	$I_{CP}=3A, I_{B1(end)}=0.8A$	-	0.5	1.0	μs

Fig. t_f TEST CIRCUIT

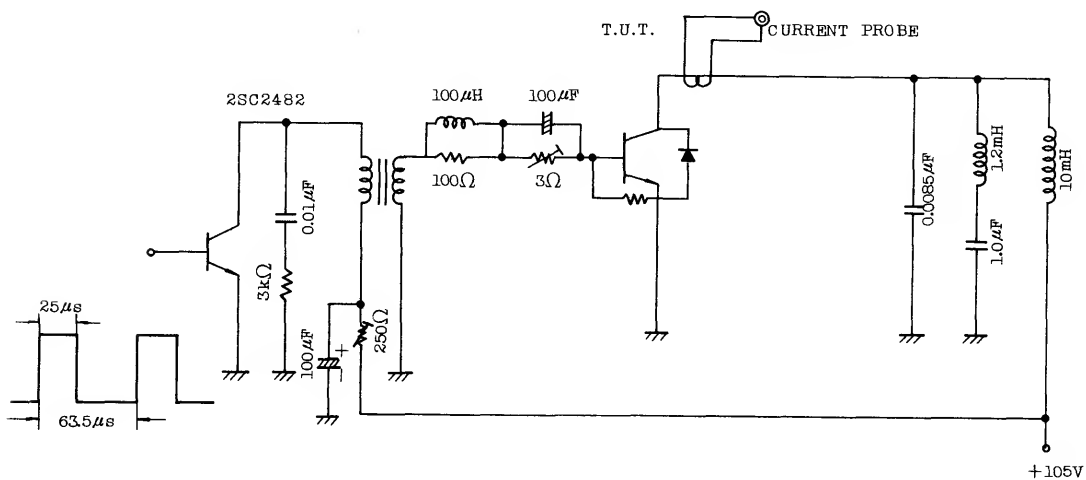

BASE CURRENT

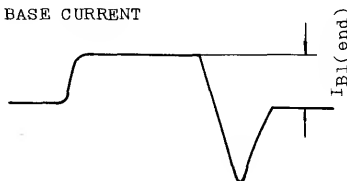

COLLECTOR CURRENT

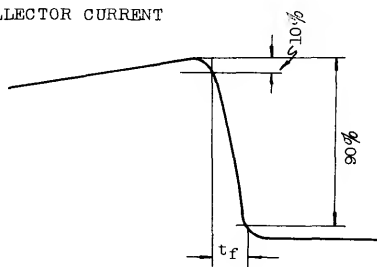

2SD869

