

TOSHIBA**2SK2842**TOSHIBA FIELD EFFECT TRANSISTOR SILICON N CHANNEL MOS TYPE (π -MOS V)**2SK2842**

HIGH SPEED, HIGH CURRENT SWITCHING APPLICATIONS

CHOPPER REGULATOR, DC-DC CONVERTER AND MOTOR DRIVE APPLICATIONS

INDUSTRIAL APPLICATIONS

Unit in mm

- Low Drain-Source ON Resistance : $R_{DS(ON)} = 0.4 \Omega$ (Typ.)
- High Forward Transfer Admittance : $|Y_{fs}| = 9.0 S$ (Typ.)
- Low Leakage Current : $I_{DSS} = 100 \mu A$ (Max.) ($V_{DS} = 500 V$)
- Enhancement-Mode : $V_{th} = 2.0 \sim 4.0 V$
($V_{DS} = 10 V, I_D = 1 mA$)

MAXIMUM RATINGS ($T_a = 25^\circ C$)

CHARACTERISTIC		SYMBOL	RATING	UNIT
Drain-Source Voltage		V_{DSS}	500	V
Drain-Gate Voltage ($R_{GS} = 20 k\Omega$)		V_{DGR}	500	V
Gate-Source Voltage		V_{GSS}	± 30	V
Drain Current	DC	I_D	12	A
	Pulse	I_{DP}	48	A
Drain Power Dissipation ($T_c = 25^\circ C$)		P_D	40	W
Single Pulse Avalanche Energy**		E_{AS}	364	mJ
Avalanche Current		I_{AR}	12	A
Repetitive Avalanche Energy*		E_{AR}	4.0	mJ
Channel Temperature		T_{ch}	150	$^\circ C$
Storage Temperature Range		T_{stg}	$-55 \sim 150$	$^\circ C$

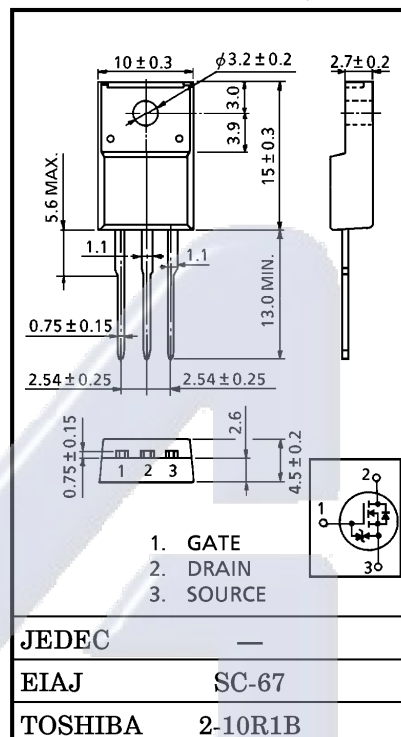

Weight : 1.9 g (Typ.)

THERMAL CHARACTERISTICS

CHARACTERISTIC	SYMBOL	MAX.	UNIT
Thermal Resistance, Channel to Case	$R_{th(ch-c)}$	3.125	$^\circ C / W$
Thermal Resistance, Channel to Ambient	$R_{th(ch-a)}$	62.5	$^\circ C / W$

Note ;

* Repetitive rating ; Pulse Width Limited by Max. junction temperature.

** $V_{DD} = 90 V$, Starting $T_{ch} = 25^\circ C$, $L = 4.3 mH$, $R_G = 25 \Omega$, $I_{AR} = 12 A$ **This transistor is an electrostatic sensitive device.****Please handle with caution.**

TOSHIBA**2SK2842**

ELECTRICAL CHARACTERISTICS (Ta = 25°C)

CHARACTERISTIC		SYMBOL	TEST CONDITION	MIN.	TYP.	MAX.	UNIT
Gate Leakage Current		I_{GSS}	$V_{GS} = \pm 25 \text{ V}, V_{DS} = 0 \text{ V}$	—	—	± 10	μA
Gate-Source Breakdown Voltage		$V_{(BR)GSS}$	$I_G = \pm 10 \mu\text{A}, V_{DS} = 0 \text{ V}$	± 30	—	—	V
Drain Cut-off Current		I_{DSS}	$V_{DS} = 500 \text{ V}, V_{GS} = 0 \text{ V}$	—	—	100	μA
Drain-Source Breakdown Voltage		$V_{(BR)DSS}$	$I_D = 10 \text{ mA}, V_{GS} = 0 \text{ V}$	500	—	—	V
Gate Threshold Voltage		V_{th}	$V_{DS} = 10 \text{ V}, I_D = 1 \text{ mA}$	2.0	—	4.0	V
Drain-Source ON Resistance		$R_{DS(ON)}$	$V_{GS} = 10 \text{ V}, I_D = 6 \text{ A}$	—	0.4	0.52	Ω
Forward Transfer Admittance		$ Y_{fs} $	$V_{DS} = 10 \text{ V}, I_D = 6 \text{ A}$	4.0	9.0	—	S
Input Capacitance		C_{iss}	$V_{DS} = 10 \text{ V}, V_{GS} = 0 \text{ V},$ $f = 1 \text{ MHz}$	—	2040	—	pF
Reverse Transfer Capacitance		C_{rss}		—	200	—	
Output Capacitance		C_{oss}		—	640	—	
Switching Time	Rise Time	t_r	<p>$V_{GS} = 10 \text{ V}$ $V_{GS} = 0 \text{ V}$ $I_D = 6 \text{ A}$ $R_L = 33 \Omega$ $V_{DD} \cong 200 \text{ V}$</p>	—	22	—	ns
	Turn-on Time	t_{on}		—	58	—	
	Fall Time	t_f		—	36	—	
	Turn-off Time	t_{off}		$V_{IN} : t_r, t_f < 5 \text{ ns},$ $\text{Duty} \leq 1\%, t_w = 10 \mu\text{s}$	—	180	
Total Gate Charge (Gate-Source Plus Gate-Drain)		Q_g	$V_{DD} \cong 400 \text{ V}, V_{GS} = 10 \text{ V},$ $I_D = 12 \text{ A}$	—	45	—	nC
Gate-Source Charge		Q_{gs}		—	25	—	
Gate-Drain ("Miller") Charge		Q_{gd}		—	20	—	

SOURCE-DRAIN DIODE RATINGS AND CHARACTERISTICS (Ta = 25°C)

CHARACTERISTIC	SYMBOL	TEST CONDITION	MIN.	TYP.	MAX.	UNIT
Continuous Drain Reverse Current	I_{DR}	—	—	—	12	A
Pulse Drain Reverse Current	I_{DRP}	—	—	—	48	A
Diode Forward Voltage	V_{DSF}	$I_{DR} = 12 \text{ A}, V_{GS} = 0 \text{ V}$	—	—	-1.7	V
Reverse Recovery Time	t_{rr}	$I_{DR} = 12 \text{ A}, V_{GS} = 0 \text{ V}$	—	1200	—	ns
Reverse Recovery Charge	Q_{rr}	$dI_{DR}/dt = 100 \text{ A}/\mu\text{s}$	—	16	—	μC

MARKING

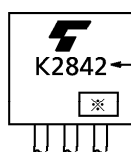

TYPE

※ Lot Number

□ □ — Month (Starting from Alphabet A)

□ — Year (Last Number of the Christian Era)

1999-06-24 2/5

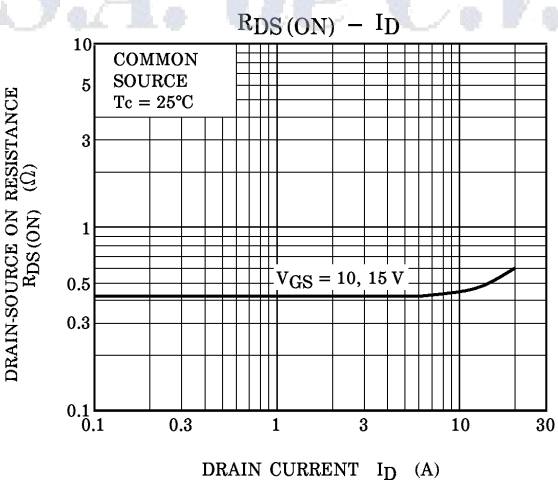
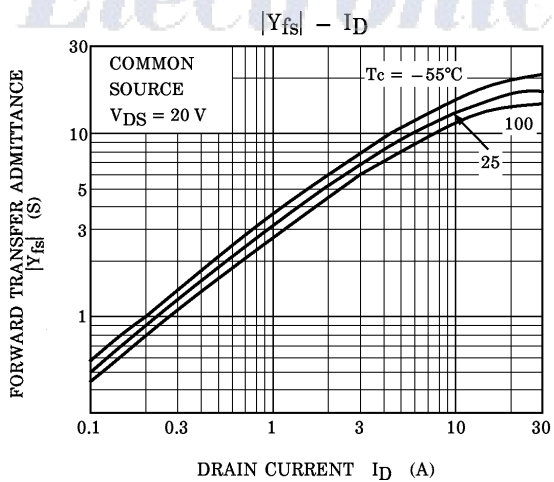
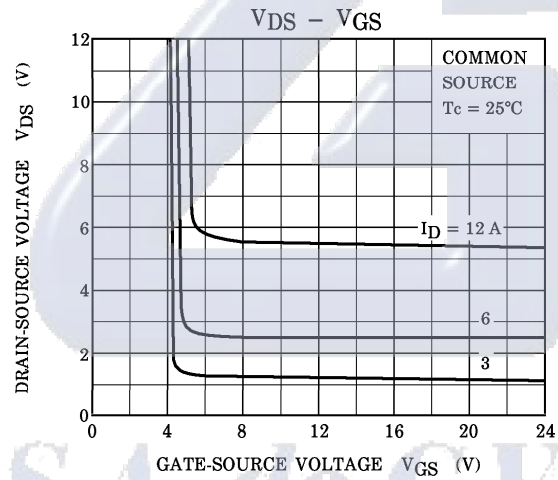
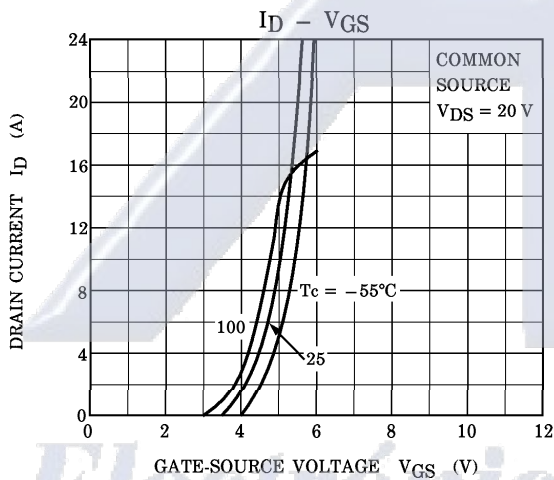
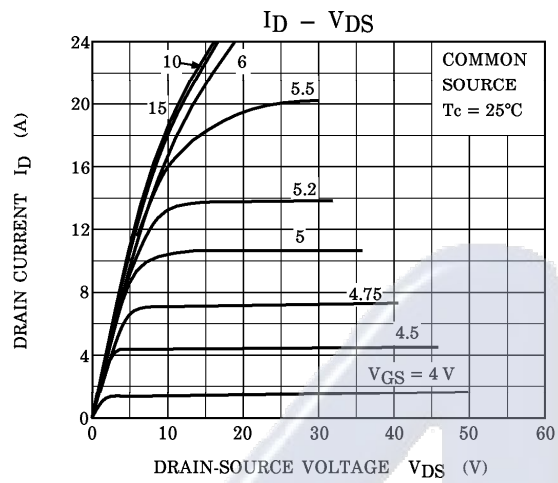
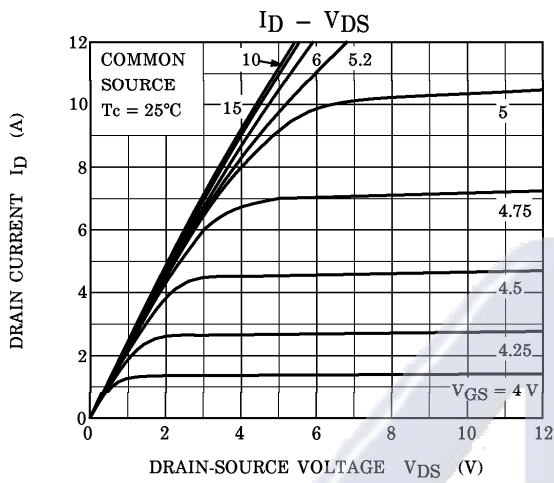

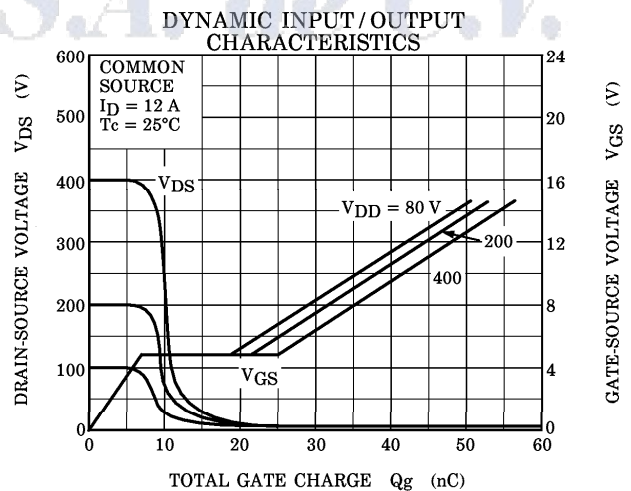
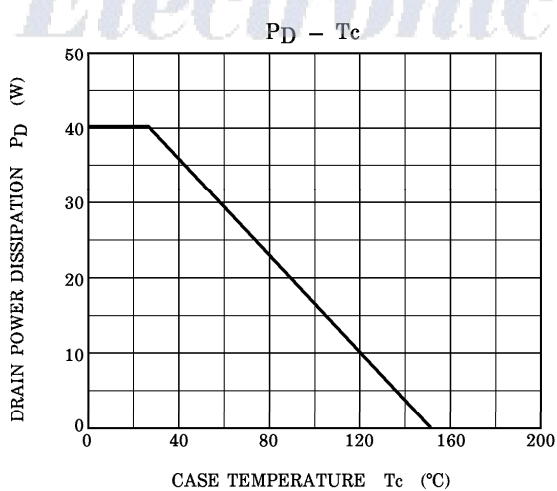
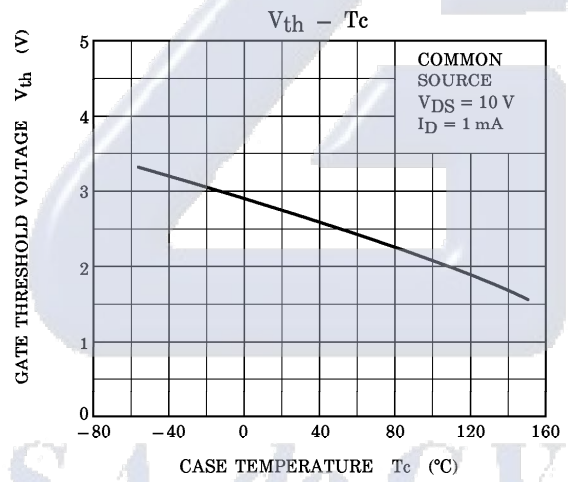
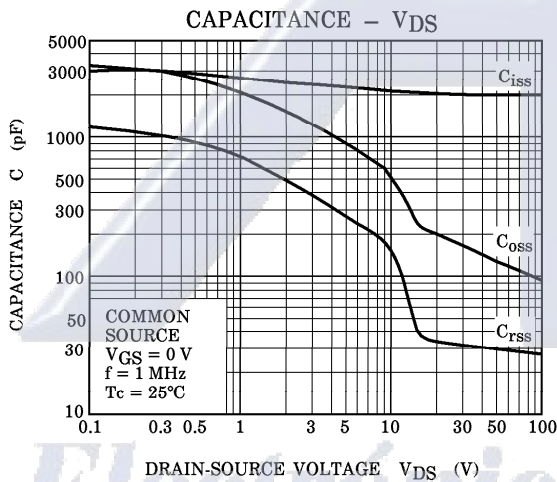
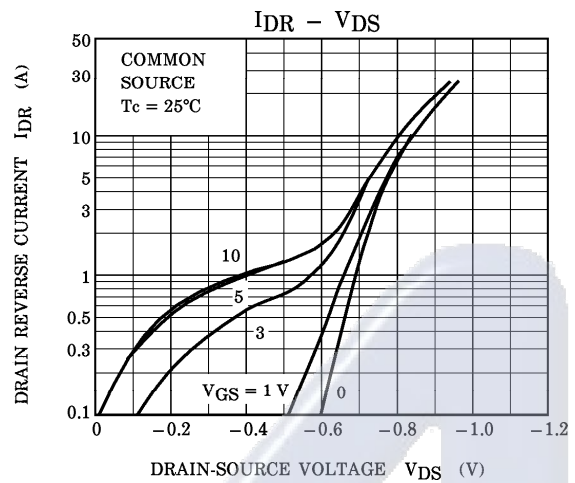
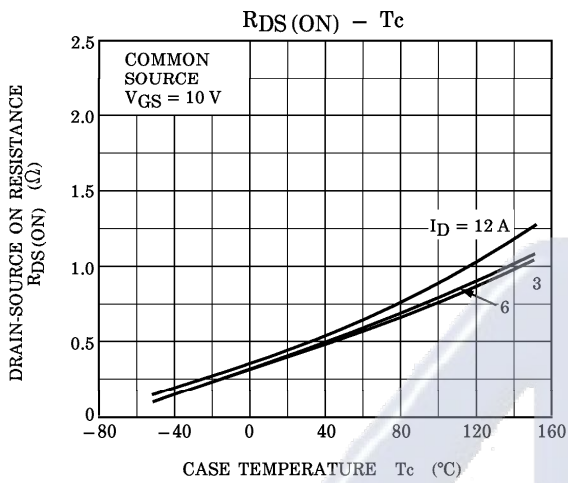

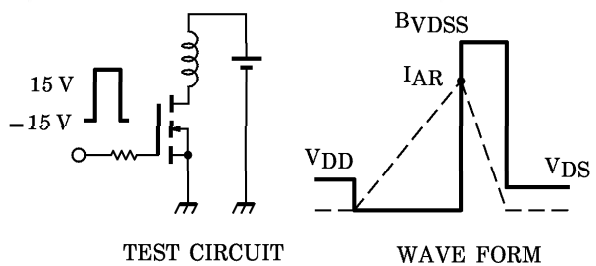
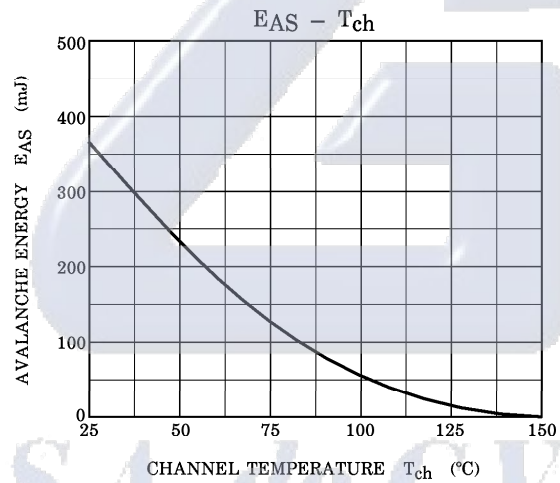
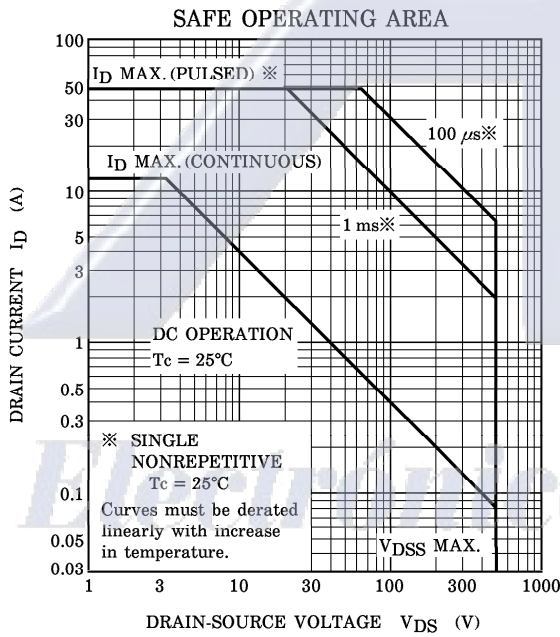
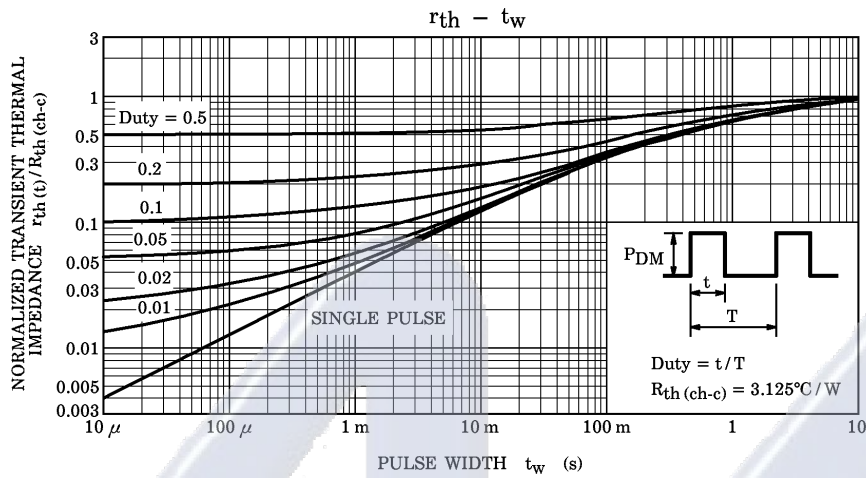

Peak $I_{AR} = 12 A$, $R_G = 25 \Omega$
 $V_{DD} = 90 V$, $L = 4.3 mH$

$$E_{AS} = \frac{1}{2} \cdot L \cdot I^2 \cdot \left(\frac{BVDSS}{BVDSS - V_{DD}} \right)$$