

Bulletin I20201 rev. A 09/98

International IR Rectifier

40HF(R) SERIES

STANDARD RECOVERY DIODES

Stud Version

Features

- High surge current capability
- Designed for a wide range of applications
- Stud cathode and stud anode version
- Leaded version available
- Types up to 1600V V_{RRM}

Typical Applications

- Battery charges
- Converters
- Power supplies
- Machine tool controls

40 A

Major Ratings and Characteristics

Parameters	40HF(R)		Units	
	10 to 120	140 to 160		
$I_{F(AV)}$	40	40	A	
@ T_C	140	110	°C	
$I_{F(RMS)}$	62		A	
I_{FSM}	@ 50Hz	570	A	
	@ 60Hz	595	A	
I^2t	@ 50Hz	1600	A ² s	
	@ 60Hz	1450	A ² s	
V_{RRM}	range	100 to 1200	1400 to 1600	V
T_J	range	- 65 to 190	- 65 to 160	°C



40HF(R) Series

Bulletin I20201 rev. A 09/98

International
IRF Rectifier**ELECTRICAL SPECIFICATIONS**

Voltage Ratings

Type number	Voltage Code	V_{RRM} , maximum repetitive peak reverse voltage V	V_{RSM} , maximum non-repetitive peak reverse voltage V	$V_{R(BR)}$, minimum avalanche voltage V (1)	I_{RRM} max. @ $T_J = T_J$ max. mA
40HF(R)	10	100	200	--	15
	20	200	300	--	
	40	400	500	500	9
	60	600	720	725	
	80	800	960	950	
	100	1000	1200	1150	
	120	1200	1440	1350	4.5
	140	1400	1650	1550	
160	1600	1900	1750		

(1) Avalanche version only available from V_{RRM} 400V to 1600V.

Forward Conduction

Parameter	40HF(R)		Units	Conditions	
	10 to 120	140 to 160			
$I_{F(AV)}$ Max. average forward current @ Case temperature	40	40	A	180° conduction, half sine wave	
$I_{F(RMS)}$ Max. RMS forward current	140	110	A		
P_R Maximum non-repetitive peak reverse power	62		K · W	10µs square pulse, $T_J = T_J$ max. see note (2)	
I_{FSM} Max. peak, one-cycle forward, non-repetitive surge current	11		A	Sinusoidal half wave, Initial $T_J = T_J$ max.	
	570				$t = 10ms$ No voltage
	595				$t = 8.3ms$ reappplied
	480				$t = 10ms$ 100% V_{RRM}
I^2t Maximum I^2t for fusing	500		A ² s	reappplied	
	1600				$t = 10ms$ No voltage
	1450				$t = 8.3ms$ reappplied
	1150				$t = 10ms$ 100% V_{RRM}
$I^2\sqrt{t}$ Maximum $I^2\sqrt{t}$ for fusing	1050		A ² √s	$t = 0.1$ to 10ms, no voltage reappplied	
	16000				
$V_{F(TO)1}$ Low level value of threshold voltage	0.65		V	$(16.7\% \times \pi \times I_{F(AV)} < I < \pi \times I_{F(AV)})$, $T_J = T_J$ max.	
$V_{F(TO)2}$ High level value of threshold voltage	0.70		V	$(I > \pi \times I_{F(AV)})$, $T_J = T_J$ max.	
r_{f1} Low level value of forward slope resistance	4.29		mΩ	$(16.7\% \times \pi \times I_{F(AV)} < I < \pi \times I_{F(AV)})$, $T_J = T_J$ max.	
r_{f2} High level value of forward slope resistance	3.98				
V_{FM} Max. forward voltage drop	1.30		V	$I_{pk} = 125A$, $T_J = 25^\circ C$, $t_p = 400\mu s$ rectangular wave	

(2) Available only for Avalanche version, all other parameters the same as 40HF.

Thermal and Mechanical Specifications

Parameter	40HF(R)		Units	Conditions
	10 to 120	140 to 160		
T _J Max. junction operating temperature range	-65 to 190	-65 to 160	°C	
T _{stg} Max. storage temperature range	-65 to 190	-65 to 160		
R _{thJC} Max. thermal resistance, junction to case	1.0		K/W	DC operation
R _{thCS} Max. thermal resistance, case to heatsink	0.25			Mounting surface, smooth, flat and greased
T Max. allowed mounting torque ±10%	2.3 - 3.4		Nm	Not lubricated threads
	20 - 30		lbf·in	
wt Approximate weight	17 (0.6)		g (oz)	
Case style	DO-203AB (DO5)		See Outline Table	

ΔR_{thJC} Conduction

(The following table shows the increment of thermal resistance R_{thJC} when devices operate at different conduction angles than DC)

Conduction angle	Sinusoidal conduction	Rectangular conduction	Units	Conditions
180°	0.14	0.10	K/W	T _J = T _J max.
120°	0.16	0.17		
90°	0.21	0.22		
60°	0.30	0.31		
30°	0.50	0.50		

Ordering Information Table

Device Code

40	HF	R	160	M
①	②	③	④	⑤

- 1** - 40 = Standard device
 41 = Not isolated lead
 42 = Isolated lead with silicone sleeve
 (Red = Reverse polarity)
 (Blue = Normal polarity)
- 2** - HF = Standard diode
 HA = Avalanche diode
- 3** - None = Stud Normal Polarity (Cathode to Stud)
 R = Stud Reverse Polarity (Anode to Stud)
- 4** - Voltage code: Code x 10 = V_{RRM} (See Voltage Ratings table)
- 5** - None = Stud base DO-203AB (DO-5) 1/4" 28UNF-2A
 M = Stud base DO-203AB (DO-5) M6 X 1 - (Not available for Avalanche diodes)

40HF(R) Series

Bulletin I20201 rev. A 09/98

International
IRF Rectifier

Outlines Table

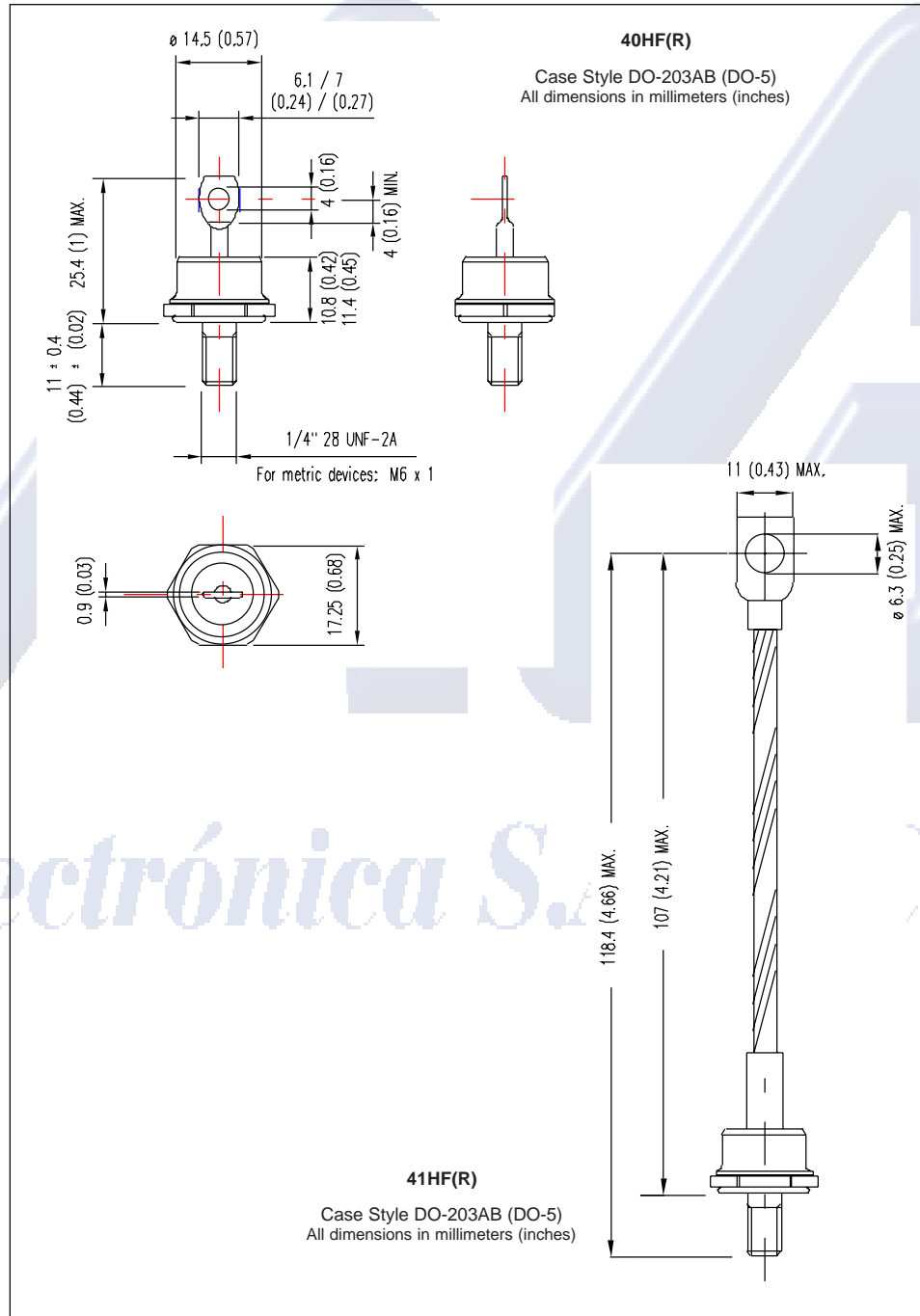

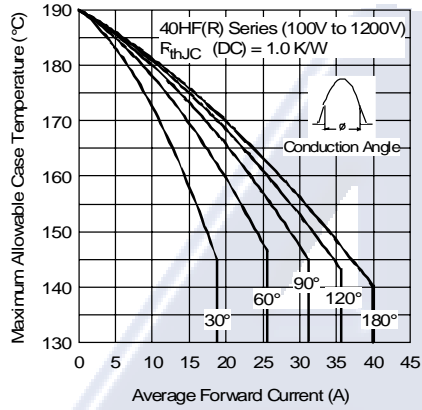

Fig. 1 - Current Ratings Characteristics

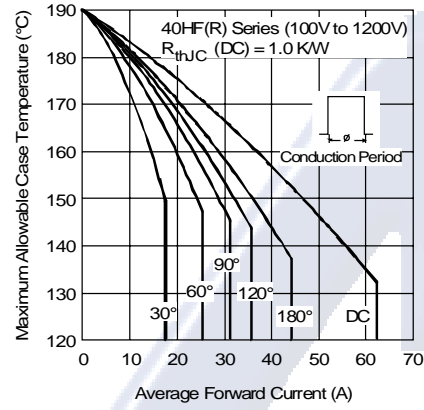

Fig. 2 - Current Ratings Characteristics

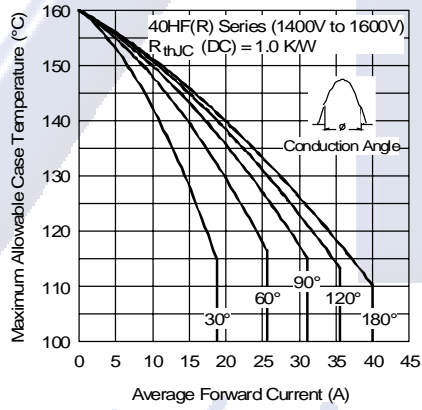

Fig. 3 - Current Ratings Characteristics

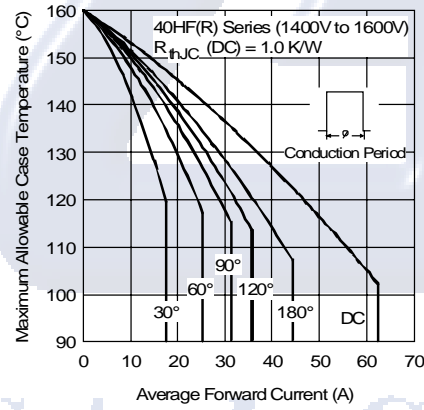

Fig. 4 - Current Ratings Characteristics

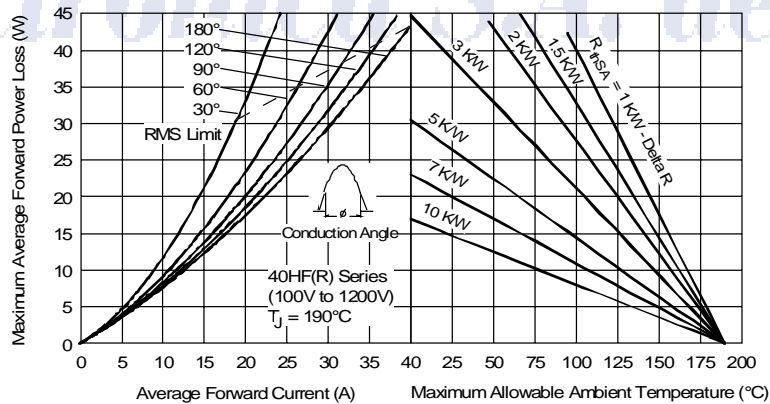

Fig. 5 - Forward Power Loss Characteristics

40HF(R) Series

Bulletin I20201 rev. A 09/98

International
IRF Rectifier

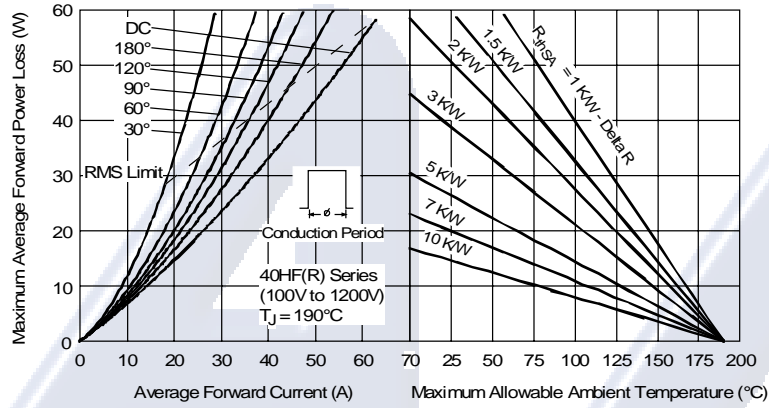

Fig. 6 - Forward Power Loss Characteristics

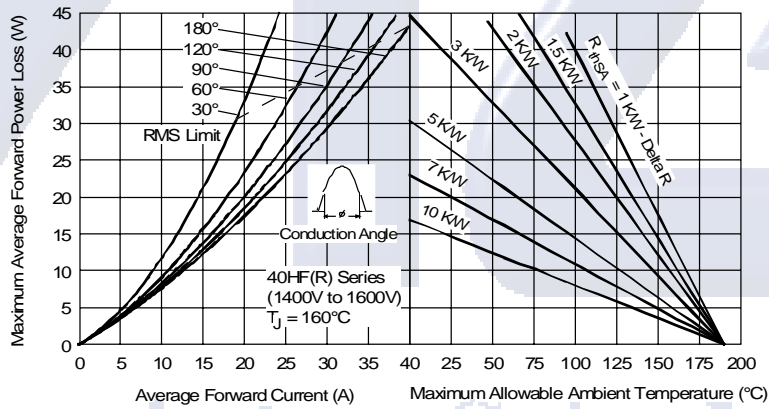

Fig. 7 - Forward Power Loss Characteristics

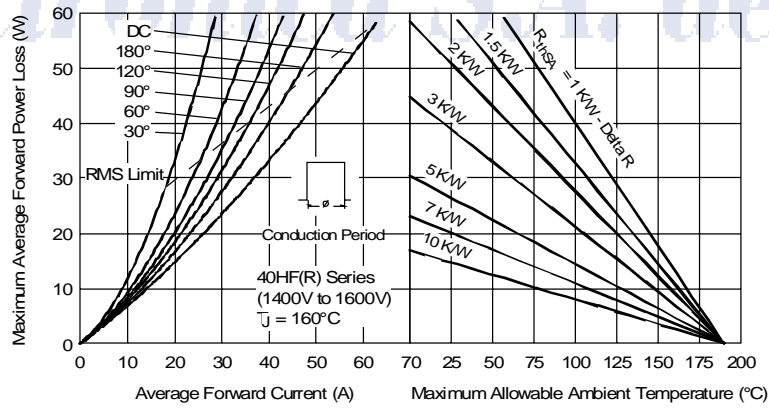

Fig. 8 - Forward Power Loss Characteristics

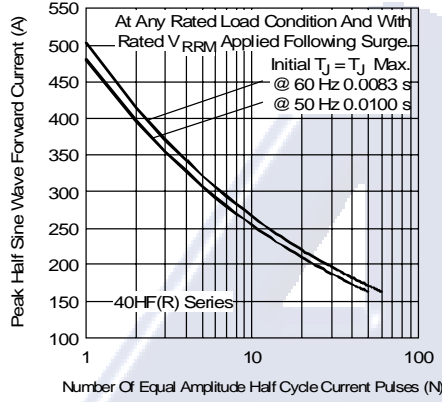

Fig. 9 - Maximum Non-Repetitive Surge Current

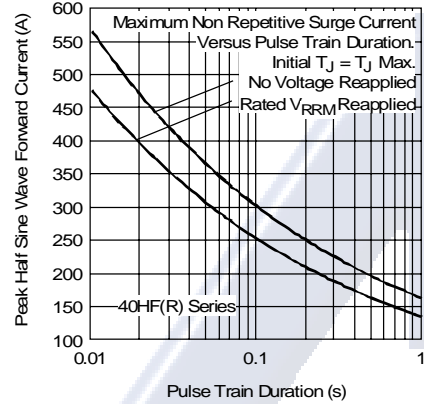

Fig. 10 - Maximum Non-Repetitive Surge Current

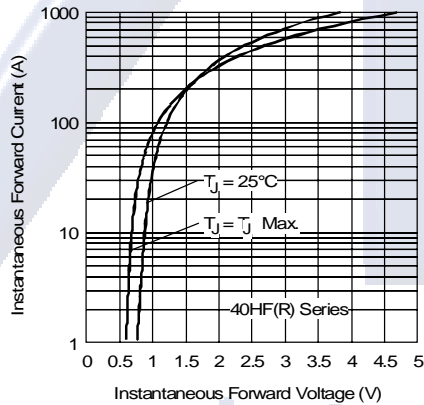

Fig. 11 - Forward Voltage Drop Characteristics

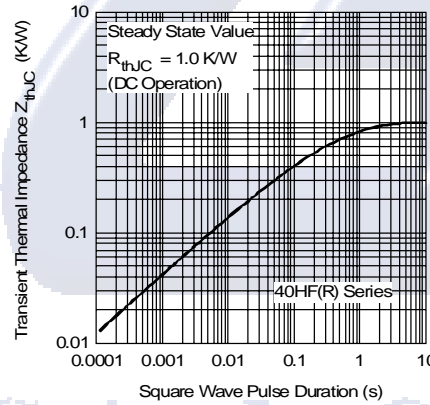

Fig. 12 - Thermal Impedance Z_{thJC} Characteristics

Electrónica S.A. de C.V.