



September 1986
Revised February 2000

DM7445 BCD to Decimal Decoders/Drivers

General Description

These BCD-to-decimal decoders/drivers consist of eight inverters and ten, four-input NAND gates. The inverters are connected in pairs to make BCD input data available for decoding by the NAND gates. Full decoding of BCD input logic ensures that all outputs remain OFF for all invalid (10–15) binary input conditions. These decoders feature high-performance, NPN output transistors designed for use as indicator/relay drivers, or as open-collector logic-circuit drivers. The high-breakdown output transistors are compatible for interfacing with most MOS integrated circuits.

Features

- Full decoding of input logic
- 80 mA sink-current capability
- All outputs are off for invalid BCD input conditions

Ordering Code:

Order Number	Package Number	Package Description
DM7445	N16E	16-Lead Plastic Dual-In-Line Package (PDIP), JEDEC MS-001, 0.300 Wide

Connection Diagram

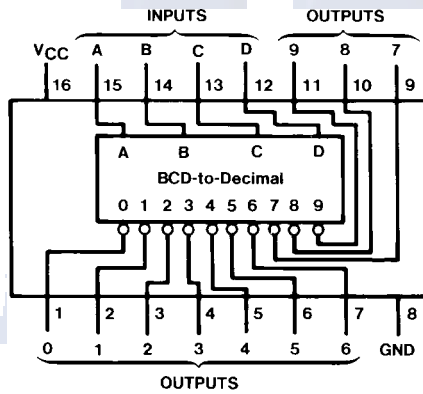

DM7445 BCD to Decimal Decoders/Drivers

DM7445

Function Table

No.	Inputs				Outputs									
	D	C	B	A	0	1	2	3	4	5	6	7	8	9
0	L	L	L	L	L	H	H	H	H	H	H	H	H	H
1	L	L	L	H	H	L	H	H	H	H	H	H	H	H
2	L	L	H	L	H	H	L	H	H	H	H	H	H	H
3	L	L	H	H	H	H	H	L	H	H	H	H	H	H
4	L	H	L	L	H	H	H	H	L	H	H	H	H	H
5	L	H	L	H	H	H	H	H	H	L	H	H	H	H
6	L	H	H	L	H	H	H	H	H	H	L	H	H	H
7	L	H	H	H	H	H	H	H	H	H	H	L	H	H
8	H	L	L	L	H	H	H	H	H	H	H	H	L	H
9	H	L	L	H	H	H	H	H	H	H	H	H	H	L
I	H	L	H	L	H	H	H	H	H	H	H	H	H	H
N	H	L	H	H	H	H	H	H	H	H	H	H	H	H
V	H	H	L	L	H	H	H	H	H	H	H	H	H	H
A	H	H	L	H	H	H	H	H	H	H	H	H	H	H
L	H	H	H	L	H	H	H	H	H	H	H	H	H	H
I	H	H	H	H	H	H	H	H	H	H	H	H	H	H
D														

H = HIGH Level (OFF)
L = LOW Level (ON)

Logic Diagram

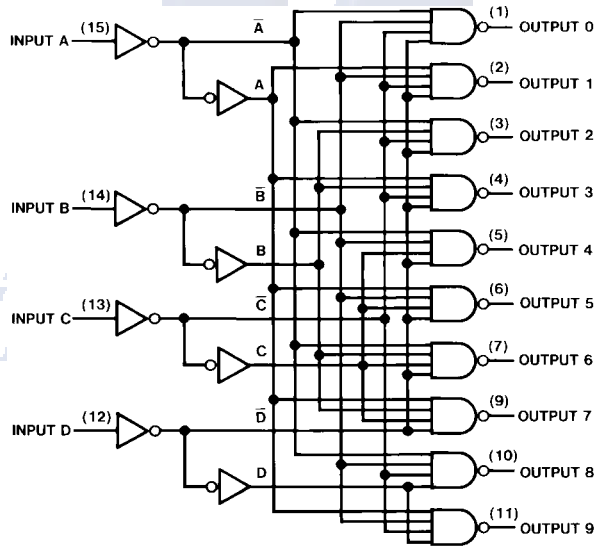

Absolute Maximum Ratings(Note 1)

Supply Voltage	7V
Input Voltage	5.5V
Output Voltage	30V
Operating Free Air Temperature Range	0°C to +70°C
Storage Temperature Range	-65°C to +150°C

Note 1: The "Absolute Maximum Ratings" are those values beyond which the safety of the device cannot be guaranteed. The device should not be operated at these limits. The parametric values defined in the Electrical Characteristics tables are not guaranteed at the absolute maximum ratings. The "Recommended Operating Conditions" table will define the conditions for actual device operation.

Recommended Operating Conditions

Symbol	Parameter	Min	Nom	Max	Units
V _{CC}	Supply Voltage	4.75	5	5.25	V
V _{IH}	HIGH Level Input Voltage	2			V
V _{IL}	LOW Level Input Voltage			0.8	V
V _{OH}	HIGH Level Output Voltage			30	V
I _{OL}	LOW Level Output Current			20	mA
T _A	Free Air Operating Temperature	0		70	°C

Electrical Characteristics

over recommended operating free air temperature range (unless otherwise noted)

Symbol	Parameter	Conditions	Min	Typ (Note 2)	Max	Units
V _I	Input Clamp Voltage	V _{CC} = Min, I _I = -12 mA			-1.5	V
I _{CEX}	HIGH Level Output Current	V _{CC} = Min, V _O = 30V V _{IL} = Max, V _{IH} = Min			250	μA
V _{OL}	LOW Level Output Voltage	V _{CC} = Min, I _{OL} = Max V _{IH} = Min, V _{IL} = Max		0.2	0.4	V
		I _{OL} = 80 mA V _{CC} = Min		0.5	0.9	
I _I	Input Current @ Max Input Voltage	V _{CC} = Max, V _I = 5.5V			1	mA
I _{IH}	HIGH Level Input Current	V _{CC} = Max, V _I = 2.4V			40	μA
I _{IL}	LOW Level Input Current	V _{CC} = Max, V _I = 0.4V			-1.6	mA
I _{CC}	Supply Current	V _{CC} = Max (Note 3)		43	70	mA

Note 2: All typicals are at V_{CC} = 5V, T_A = 25°C.

Note 3: I_{CC} is measured with all inputs grounded and all outputs OPEN.

Switching Characteristics

at V_{CC} = 5V and T_A = 25°C

Symbol	Parameter	Conditions	Min	Max	Units
t _{PLH}	Propagation Delay Time LOW-to-HIGH Level Output	C _L = 15 pF R _L = 100Ω		49.5	ns
t _{PHL}	Propagation Delay Time HIGH-to-LOW Level Output			49.5	ns

DM7445 BCD to Decimal Decoders/Drivers

Physical Dimensions inches (millimeters) unless otherwise noted

16-Lead Plastic Dual-In-Line Package (PDIP), JEDEC MS-001, 0.300 Wide Package Number N16E

N16E (REV F)

Fairchild does not assume any responsibility for use of any circuitry described, no circuit patent licenses are implied and Fairchild reserves the right at any time without notice to change said circuitry and specifications.

LIFE SUPPORT POLICY

FAIRCHILD'S PRODUCTS ARE NOT AUTHORIZED FOR USE AS CRITICAL COMPONENTS IN LIFE SUPPORT DEVICES OR SYSTEMS WITHOUT THE EXPRESS WRITTEN APPROVAL OF THE PRESIDENT OF FAIRCHILD SEMICONDUCTOR CORPORATION. As used herein:

1. Life support devices or systems are devices or systems which, (a) are intended for surgical implant into the body, or (b) support or sustain life, and (c) whose failure to perform when properly used in accordance with instructions for use provided in the labeling, can be reasonably expected to result in a significant injury to the user.
2. A critical component in any component of a life support device or system whose failure to perform can be reasonably expected to cause the failure of the life support device or system, or to affect its safety or effectiveness.

www.fairchildsemi.com