

SN54LS06, SN54LS16, SN74LS06, SN74LS16 HEX INVERTER BUFFERS/DRIVERS WITH OPEN-COLLECTOR HIGH-VOLTAGE OUTPUTS

SDLS020A – MAY 1990

- Converts TTL Voltage Levels to MOS Levels
- High Sink-Current Capability
- Input Clamping Diodes Simplify System Design
- Open-Collector Driver for Indicator Lamps and Relays
- Package Options Include “Small Outline” Packages, Ceramic Chip Carriers, and Standard Plastic and Ceramic 300-mil DIPs

description

These monolithic hex inverter buffers/drivers feature high-voltage open-collector outputs to interface with high-level circuits (such as MOS), or for driving high-current loads, and are also characterized for use as inverter buffers for driving TTL inputs. The 'LS06 has a rated output voltage of 30 V and the 'LS16 has a rated output voltage of 15 V. The maximum sink current for the SN54LS06 and SN54LS16 is 30 mA and the SN74LS06 and SN74LS16 is 40 mA.

These circuits are compatible with most TTL families. Inputs are diode-clamped to minimize transmission-effects, which simplifies design. Typical power dissipation is 175 mW and average propagation delay time is 8 ns.

The SN54LS06 and SN54LS16 are characterized over the full military temperature range of -55°C to 125°C . The SN74LS06 and SN74LS16 are characterized for operation from 0°C to 70°C .

logic symbol†

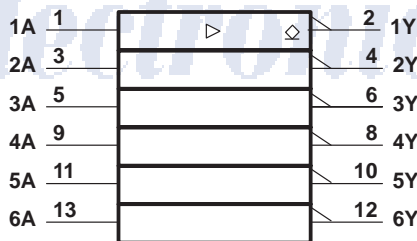

† This symbol is in accordance with ANSI/IEEE Std 91-1984 and IEC Publication 617-12.

Pin numbers shown are for D, J, and N packages.

SN54LS06, SN54LS16 . . . J PACKAGE
SN74LS06, SN74LS16 . . . D OR N PACKAGE
(TOP VIEW)

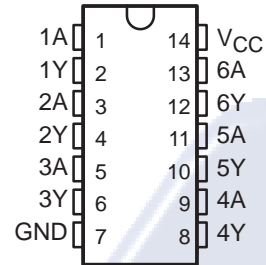

SN54LS06, SN54LS16 . . . FK PACKAGE
(TOP VIEW)

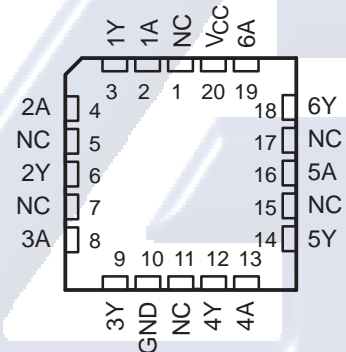

NC – No internal connection

logic diagram (positive logic)

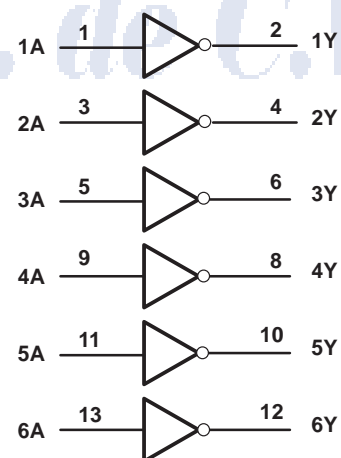

SN54LS06, SN54LS16, SN74LS06, SN74LS16 HEX INVERTER BUFFERS/DRIVERS WITH OPEN-COLLECTOR HIGH-VOLTAGE OUTPUTS

SDLS020A – MAY 1990

schematic (each gate)

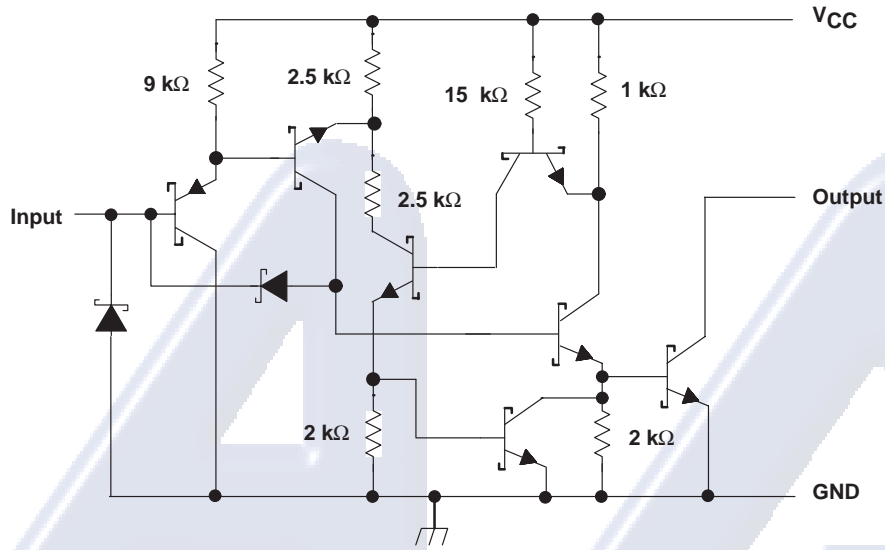

absolute maximum ratings over operating free-air temperature range (unless otherwise noted)†

| | |
|---|----------------|
| Supply voltage, V_{CC} | 7 V |
| Input voltage, V_I (see Note 1) | 5.5 V |
| Output voltage, V_O (see Notes 1 and 2): SN54LS06, SN74LS06 | 30 V |
| SN54LS16, SN74LS16 | 15 V |
| Operating free-air temperature range: SN54LS06, SN54LS16 | -55°C to 125°C |
| SN74LS06, SN74LS16 | 0°C to 70°C |
| Storage temperature range | -65°C to 150°C |

† Stresses beyond those listed under “absolute maximum ratings” may cause permanent damage to the device. This are stress ratings only, and functional operation of the device at these or any other conditions beyond those indicated under “recommended operating conditions” is not implied. Exposure to absolute-maximum-rated conditions for extended periods may affect device reliability.

NOTES: 1. Voltage values are with respect to network ground terminal.

2. This is the maximum voltage that should be applied to any output when it is in the off state.

recommended operating conditions

| | | SN54LS06 | | | SN74LS06 | | | UNIT |
|----------|--------------------------------|----------|-----|-----|----------|-----|------|------|
| | | SN54LS16 | | | SN74LS16 | | | |
| | | MIN | NOM | MAX | MIN | NOM | MAX | |
| V_{CC} | Supply voltage | 4.5 | 5 | 5.5 | 4.75 | 5 | 5.25 | V |
| V_{IH} | High-level input voltage | 2 | | | 2 | | | V |
| V_{IL} | Low-level input voltage | | | 0.8 | | | 0.8 | V |
| V_{OH} | High-level output voltage | | | 30 | | | 30 | V |
| | | | | 15 | | | 15 | |
| I_{OL} | Low-level output current | | | 30 | | | 40 | mA |
| T_A | Operating free-air temperature | -55 | | 125 | 0 | | 70 | °C |

PRODUCT PREVIEW information concerns products in the formative or design phase of development. Characteristic data and other specifications are design goals. Texas Instruments reserves the right to change or discontinue these products without notice.



POST OFFICE BOX 655303 • DALLAS, TEXAS 75265

SN54LS06, SN54LS16, SN74LS06, SN74LS16 HEX INVERTER BUFFERS/DRIVERS WITH OPEN-COLLECTOR HIGH-VOLTAGE OUTPUTS

SDLS020A – MAY 1990

electrical characteristics over recommended operating free-air temperature range (unless otherwise noted)

| PARAMETER | TEST CONDITIONS† | | SN54LS06 SN54LS16 | | SN74LS06 SN74LS16 | | UNIT |
|-----------|-------------------------|--------------------------|--------------------------------|------|----------------------|-----|---------------|
| | | | MIN | TYP‡ | MAX | MIN | |
| V_{IK} | $V_{CC} = \text{MIN}$, | $I_I = -12 \text{ mA}$ | -1.5 | | -1.5 | | V |
| I_{OH} | $V_{CC} = \text{MIN}$, | $V_{IL} = 0.8 \text{ V}$ | 'LS06, $V_{OH} = 30 \text{ V}$ | | 0.25 | | mA |
| | | | 'LS16, $V_{OH} = 15 \text{ V}$ | | 0.25 | | |
| V_{OL} | $V_{CC} = \text{MIN}$, | $V_{IH} = 2 \text{ V}$ | $I_{OL} = 16 \text{ mA}$ | | 0.25 0.4 | | V |
| | | | $I_{OL} = 30 \text{ mA}$ | | 0.7 | | |
| | | | $I_{OL} = 40 \text{ mA}$ | | 0.7 | | |
| I_I | $V_{CC} = \text{MAX}$, | $V_I = 7 \text{ V}$ | 1 | | 1 | | mA |
| I_{IH} | $V_{CC} = \text{MAX}$, | $V_I = 2.4 \text{ V}$ | 20 | | 20 | | μA |
| I_{IL} | $V_{CC} = \text{MAX}$, | $V_I = 0.4 \text{ V}$ | -0.2 | | -0.2 | | mA |
| I_{CCH} | $V_{CC} = \text{MAX}$ | | 18 | | 18 | | mA |
| I_{CCL} | $V_{CC} = \text{MAX}$ | | 60 | | 60 | | mA |

† For conditions shown as MIN or MAX, use the appropriate value specified under recommended operating conditions.

‡ All typical values are at $V_{CC} = 5 \text{ V}$, and $T_A = 25^\circ\text{C}$.

switching characteristics, $V_{CC} = 5 \text{ V}$, $T_A = 25^\circ\text{C}$ (see Note 3)

| PARAMETER | FROM (INPUT) | TO (OUTPUT) | TEST CONDITIONS | | | UNIT | |
|-----------|-----------------|----------------|----------------------|-----------------------|----|------|----|
| t_{PLH} | A | Y | $R_L = 110 \Omega$, | $C_L = 15 \text{ pF}$ | 7 | 15 | ns |
| t_{PHL} | | | | | 10 | 20 | |

NOTE 3: Load circuit and voltage waveforms are shown in Section 1 of *TTL Logic Data Book*, 1988.

Electrónica S.A. de C.V.

PRODUCT PREVIEW information concerns products in the formative or design phase of development. Characteristic data and other specifications are design goals. Texas Instruments reserves the right to change or discontinue these products without notice.

 **TEXAS
INSTRUMENTS**

POST OFFICE BOX 655303 • DALLAS, TEXAS 75265

IMPORTANT NOTICE

Texas Instruments and its subsidiaries (TI) reserve the right to make changes to their products or to discontinue any product or service without notice, and advise customers to obtain the latest version of relevant information to verify, before placing orders, that information being relied on is current and complete. All products are sold subject to the terms and conditions of sale supplied at the time of order acknowledgement, including those pertaining to warranty, patent infringement, and limitation of liability.

TI warrants performance of its semiconductor products to the specifications applicable at the time of sale in accordance with TI's standard warranty. Testing and other quality control techniques are utilized to the extent TI deems necessary to support this warranty. Specific testing of all parameters of each device is not necessarily performed, except those mandated by government requirements.

CERTAIN APPLICATIONS USING SEMICONDUCTOR PRODUCTS MAY INVOLVE POTENTIAL RISKS OF DEATH, PERSONAL INJURY, OR SEVERE PROPERTY OR ENVIRONMENTAL DAMAGE ("CRITICAL APPLICATIONS"). TI SEMICONDUCTOR PRODUCTS ARE NOT DESIGNED, AUTHORIZED, OR WARRANTED TO BE SUITABLE FOR USE IN LIFE-SUPPORT DEVICES OR SYSTEMS OR OTHER CRITICAL APPLICATIONS. INCLUSION OF TI PRODUCTS IN SUCH APPLICATIONS IS UNDERSTOOD TO BE FULLY AT THE CUSTOMER'S RISK.

In order to minimize risks associated with the customer's applications, adequate design and operating safeguards must be provided by the customer to minimize inherent or procedural hazards.

TI assumes no liability for applications assistance or customer product design. TI does not warrant or represent that any license, either express or implied, is granted under any patent right, copyright, mask work right, or other intellectual property right of TI covering or relating to any combination, machine, or process in which such semiconductor products or services might be or are used. TI's publication of information regarding any third party's products or services does not constitute TI's approval, warranty or endorsement thereof.

Electrónica S.A. de C.V.

Copyright © 1998, Texas Instruments Incorporated