

FAIRCHILD
SEMICONDUCTOR™

August 1986
Revised March 2000

DM74LS09

Quad 2-Input AND Gates with Open-Collector Outputs

General Description

This device contains four independent gates each of which performs the logic AND function. The open-collector outputs require external pull-up resistors for proper logical operation.

Pull-Up Resistor Equations

$$R_{MAX} = \frac{V_{CC} (Min) - V_{OH}}{N_1 (I_{OH}) + N_2 (I_{IH})}$$

$$R_{MIN} = \frac{V_{CC} (Max) - V_{OL}}{I_{OL} - N_3 (I_{IL})}$$

Where:

- N₁ (I_{OH}) = total maximum output high current for all outputs tied to pull-up resistor
- N₂ (I_{IH}) = total maximum input high current for all inputs tied to pull-up resistor
- N₃ (I_{IL}) = total maximum input low current for all inputs tied to pull-up resistor

Ordering Code:

Order Number	Package Number	Package Description
DM74LS09M	M14A	14-Lead Small Outline Integrated Circuit (SOIC), JEDEC MS-120, 0.150 Narrow
DM74LS09N	N14A	14-Lead Plastic Dual-In-Line Package (PDIP), JEDEC MS-001, 0.300 Wide

Devices also available in Tape and Reel.

Connection Diagram

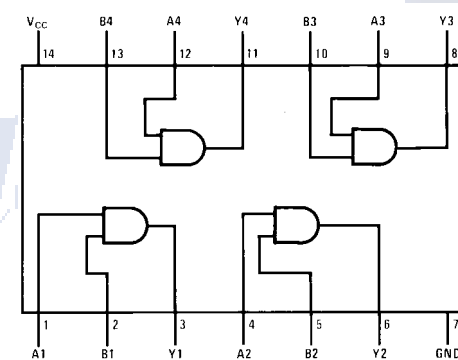

Function Table

Y = AB

Inputs		Output
A	B	Y
L	L	L
L	H	L
H	L	L
H	H	H

H = HIGH Logic Level
L = LOW Logic Level

DM74LS09 Quad 2-Input AND Gates with Open-Collector Outputs

DM74LS09

Absolute Maximum Ratings(Note 1)

Supply Voltage	7V
Input Voltage	7V
Output Voltage	7V
Operating Free Air Temperature Range	0°C to +70°C
Storage Temperature Range	-65°C to +150°C

Note 1: The "Absolute Maximum Ratings" are those values beyond which the safety of the device cannot be guaranteed. The device should not be operated at these limits. The parametric values defined in the Electrical Characteristics tables are not guaranteed at the absolute maximum ratings. The "Recommended Operating Conditions" table will define the conditions for actual device operation.

Recommended Operating Conditions

Symbol	Parameter	Min	Nom	Max	Units
V _{CC}	Supply Voltage	4.75	5	5.25	V
V _{IH}	HIGH Level Input Voltage	2			V
V _{IL}	LOW Level Input Voltage			0.8	V
V _{OH}	HIGH Level Output Voltage			5.5	V
I _{OL}	LOW Level Output Current			8	mA
T _A	Free Air Operating Temperature	0		70	°C

Electrical Characteristics

over recommended operating free air temperature range (unless otherwise noted)

Symbol	Parameter	Conditions	Min	Typ (Note 2)	Max	Units
V _I	Input Clamp Voltage	V _{CC} = Min, I _I = -18 mA			-1.5	V
I _{CEX}	HIGH Level Output Current	V _{CC} = Min, V _O = 5.5V V _{IH} = Min			100	μA
V _{OL}	LOW Level Output Voltage	V _{CC} = Min, I _{OL} = Max V _{IL} = Max I _{OL} = 4 mA, V _{CC} = Min		0.35 0.25	0.5 0.4	V
I _I	Input Current @ Max Input Voltage	V _{CC} = Max, V _I = 7V			0.1	mA
I _{IH}	HIGH Level Input Current	V _{CC} = Max, V _I = 2.7V			20	μA
I _{IL}	LOW Level Input Current	V _{CC} = Max, V _I = 0.4V			-0.36	mA
I _{CCH}	Supply Current with Outputs HIGH	V _{CC} = Max		2.4	4.8	mA
I _{CCL}	Supply Current with Outputs LOW	V _{CC} = Max		4.4	8.8	mA

Note 2: All typicals are at V_{CC} = 5V, T_A = 25°C.

Switching Characteristics

at V_{CC} = 5V and T_A = 25°C

Symbol	Parameter	R _L = 2 kΩ				Units
		C _L = 15 pF		C _L = 50 pF		
		Min	Max	Min	Max	
t _{PLH}	Propagation Delay Time LOW-to-HIGH Level Output	5	20	8	45	ns
t _{PHL}	Propagation Delay Time HIGH-to-LOW Level Output	4	15	6	27	ns

DM74LS09

Physical Dimensions inches (millimeters) unless otherwise noted

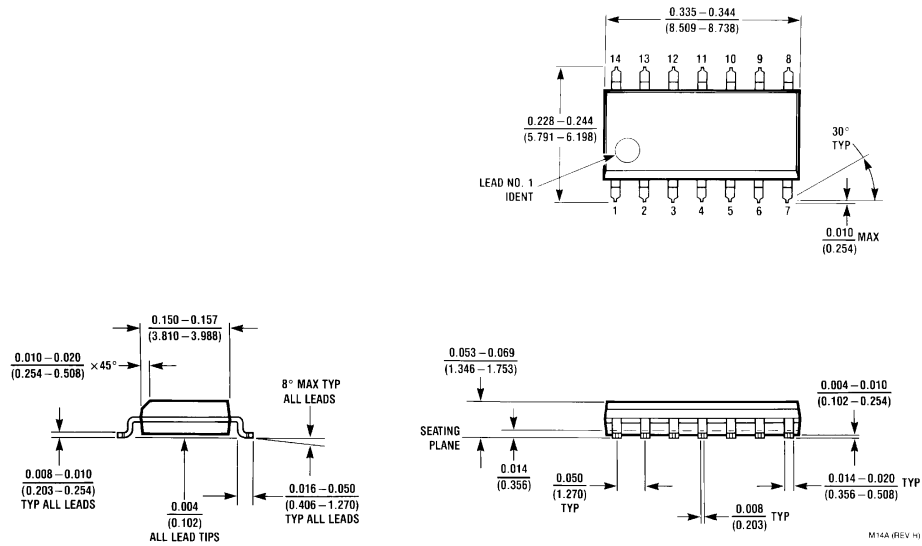

14-Lead Small Outline Integrated Circuit (SOIC), JEDEC MS-120, 0.150 Narrow Package Number M14A

M14A (REV. H)

Electrónica S.A. de C.V.

DM74LS09 Quad 2-Input AND Gates with Open-Collector Outputs

Physical Dimensions inches (millimeters) unless otherwise noted (Continued)

14-Lead Plastic Dual-In-Line Package (PDIP), JEDEC MS-001, 0.300 Wide Package Number N14A

N14A (REV F)

Fairchild does not assume any responsibility for use of any circuitry described, no circuit patent licenses are implied and Fairchild reserves the right at any time without notice to change said circuitry and specifications.

LIFE SUPPORT POLICY

FAIRCHILD'S PRODUCTS ARE NOT AUTHORIZED FOR USE AS CRITICAL COMPONENTS IN LIFE SUPPORT DEVICES OR SYSTEMS WITHOUT THE EXPRESS WRITTEN APPROVAL OF THE PRESIDENT OF FAIRCHILD SEMICONDUCTOR CORPORATION. As used herein:

- Life support devices or systems are devices or systems which, (a) are intended for surgical implant into the body, or (b) support or sustain life, and (c) whose failure to perform when properly used in accordance with instructions for use provided in the labeling, can be reasonably expected to result in a significant injury to the user.
- A critical component in any component of a life support device or system whose failure to perform can be reasonably expected to cause the failure of the life support device or system, or to affect its safety or effectiveness.

www.fairchildsemi.com