



August 1986  
Revised March 2000

# DM74LS151

## 1-of-8 Line Data Selector/Multiplexer

### General Description

This data selector/multiplexer contains full on-chip decoding to select the desired data source. The DM74LS151 selects one-of-eight data sources. The DM74LS151 has a strobe input which must be at a low logic level to enable these devices. A high level at the strobe forces the W output HIGH, and the Y output LOW.

The DM74LS151 features complementary W and Y outputs.

### Features

- Select one-of-eight data lines
- Performs parallel-to-serial conversion
- Permits multiplexing from N lines to one line
- Also for use as Boolean function generator
- Typical average propagation delay time data input to W output 12.5 ns
- Typical power dissipation 30 mW

### Ordering Code:

Order Number	Package Number	Package Description
DM74LS151M	M16A	16-Lead Small Outline Integrated Circuit (SOIC), JEDEC MS-012, 0.150 Narrow
DM74LS151SJ	M16D	16-Lead Small Outline Package (SOP), EIAJ TYPE II, 5.3mm Wide
DM74LS151N	N16E	16-Lead Plastic Dual-In-Line Package (PDIP), JEDEC MS-001, 0.300 Wide

Devices also available in Tape and Reel. Specify by appending the suffix letter "X" to the ordering code.

### Connection Diagram

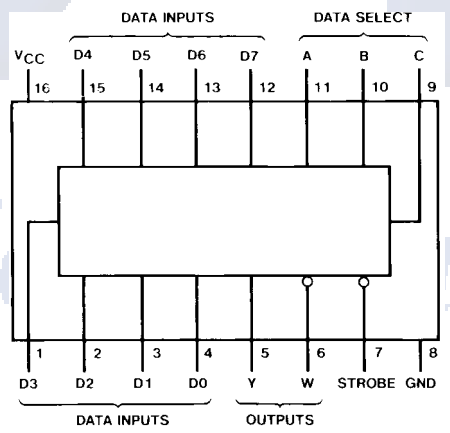

### Truth Table

Inputs				Outputs	
Select			Strobe S	Y	W
C	B	A			
X	X	X	H	L	H
L	L	L	L	D0	D0
L	L	H	L	D1	D1
L	H	L	L	D2	D2
L	H	H	L	D3	D3
H	L	L	L	D4	D4
H	L	H	L	D5	D5
H	H	L	L	D6	D6
H	H	H	L	D7	D7

H = HIGH Level  
L = LOW Level  
X = Don't Care  
D0, D1...D7 = the level of the respective D input

DM74LS151 1-of-8 Line Data Selector/Multiplexer

DM74LS151

### Logic Diagrams

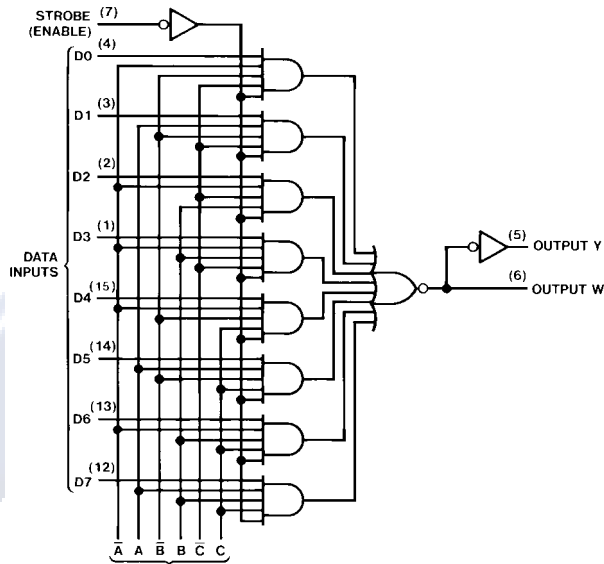

See Address Buffers

#### Address Buffers

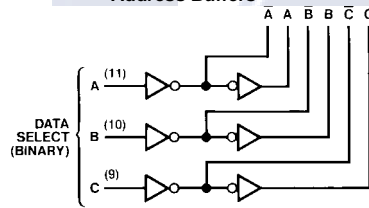

*Electrónica S.A. de C.V.*

**Absolute Maximum Ratings**(Note 1)

Supply Voltage	7V
Input Voltage	7V
Operating Free Air Temperature Range	0°C to +70°C
Storage Temperature Range	-65°C to +150°C

**Note 1:** The "Absolute Maximum Ratings" are those values beyond which the safety of the device cannot be guaranteed. The device should not be operated at these limits. The parametric values defined in the Electrical Characteristics tables are not guaranteed at the absolute maximum ratings. The "Recommended Operating Conditions" table will define the conditions for actual device operation.

**Recommended Operating Conditions**

Symbol	Parameter	Min	Nom	Max	Units
V <sub>CC</sub>	Supply Voltage	4.75	5	5.25	V
V <sub>IH</sub>	HIGH Level Input Voltage	2			V
V <sub>IL</sub>	LOW Level Input Voltage			0.8	V
I <sub>OH</sub>	HIGH Level Output Current			-0.4	mA
I <sub>OL</sub>	LOW Level Output Current			8	mA
T <sub>A</sub>	Free Air Operating Temperature	0		70	°C

**Electrical Characteristics**

over recommended operating free air temperature range (unless otherwise noted)

Symbol	Parameter	Conditions	Min	Typ (Note 2)	Max	Units
V <sub>I</sub>	Input Clamp Voltage	V <sub>CC</sub> = Min, I <sub>I</sub> = -18 mA			-1.5	V
V <sub>OH</sub>	HIGH Level Output Voltage	V <sub>CC</sub> = Min, I <sub>OH</sub> = Max V <sub>IL</sub> = Max, V <sub>IH</sub> = Min	2.7	3.4		V
V <sub>OL</sub>	LOW Level Output Voltage	V <sub>CC</sub> = Min, I <sub>OL</sub> = Max V <sub>IL</sub> = Max, V <sub>IH</sub> = Min I <sub>OL</sub> = 4 mA, V <sub>CC</sub> = Min		0.35 0.25	0.5 0.4	V
I <sub>I</sub>	Input Current @ Max Input Voltage	V <sub>CC</sub> = Max, V <sub>I</sub> = 7V			0.1	mA
I <sub>IH</sub>	HIGH Level Input Current	V <sub>CC</sub> = Max, V <sub>I</sub> = 2.7V			20	μA
I <sub>IL</sub>	LOW Level Input Current	V <sub>CC</sub> = Max, V <sub>I</sub> = 0.4V			-0.4	mA
I <sub>OS</sub>	Short Circuit Output Current	V <sub>CC</sub> = Max (Note 3)	-20		-100	mA
I <sub>CC</sub>	Supply Current	V <sub>CC</sub> = Max (Note 4)		6	10	mA

**Note 2:** All typicals are at V<sub>CC</sub> = 5V, T<sub>A</sub> = 25°C.

**Note 3:** Not more than one output should be shorted at a time, and the duration should not exceed one second.

**Note 4:** I<sub>CC</sub> is measured with all outputs OPEN, strobe and data select inputs at 4.5V, and all other inputs OPEN.

*Electrónica S.A. de C.V.*

DM74LS151

Switching Characteristics							
at $V_{CC} = 5V$ and $T_A = 25^\circ C$							
Symbol	Parameter	From (Input) To (output)	$R_L = 2\ k\Omega$				Units
			$C_L = 15\ pF$		$C_L = 50\ pF$		
			Min	Max	Min	Max	
$t_{PLH}$	Propagation Delay Time LOW-to-HIGH Level Output	Select (4 Levels) to Y		43		46	ns
$t_{PHL}$	Propagation Delay Time HIGH-to-LOW Level Output	Select (4 Levels) to Y		30		36	ns
$t_{PLH}$	Propagation Delay Time LOW-to-HIGH Level Output	Select (3 Levels) to W		23		25	ns
$t_{PHL}$	Propagation Delay Time HIGH-to-LOW Level Output	Select (3 Levels) to W		32		40	ns
$t_{PLH}$	Propagation Delay Time LOW-to-HIGH Level Output	Strobe to Y		42		44	ns
$t_{PHL}$	Propagation Delay Time HIGH-to-LOW Level Output	Strobe to Y		32		40	ns
$t_{PLH}$	Propagation Delay Time LOW-to-HIGH Level Output	Strobe to W		24		27	ns
$t_{PHL}$	Propagation Delay Time HIGH-to-LOW Level Output	Strobe to W		30		36	ns
$t_{PLH}$	Propagation Delay Time LOW-to-HIGH Level Output	D0 thru D7 to Y		32		35	ns
$t_{PHL}$	Propagation Delay Time HIGH-to-LOW Level Output	D0 thru D7 to Y		26		33	ns
$t_{PLH}$	Propagation Delay Time LOW-to-HIGH Level Output	D0 thru D7 to W		21		25	ns
$t_{PHL}$	Propagation Delay Time HIGH-to-LOW Level Output	D0 thru D7 to W		20		27	ns

DM74LS151

**Physical Dimensions** inches (millimeters) unless otherwise noted

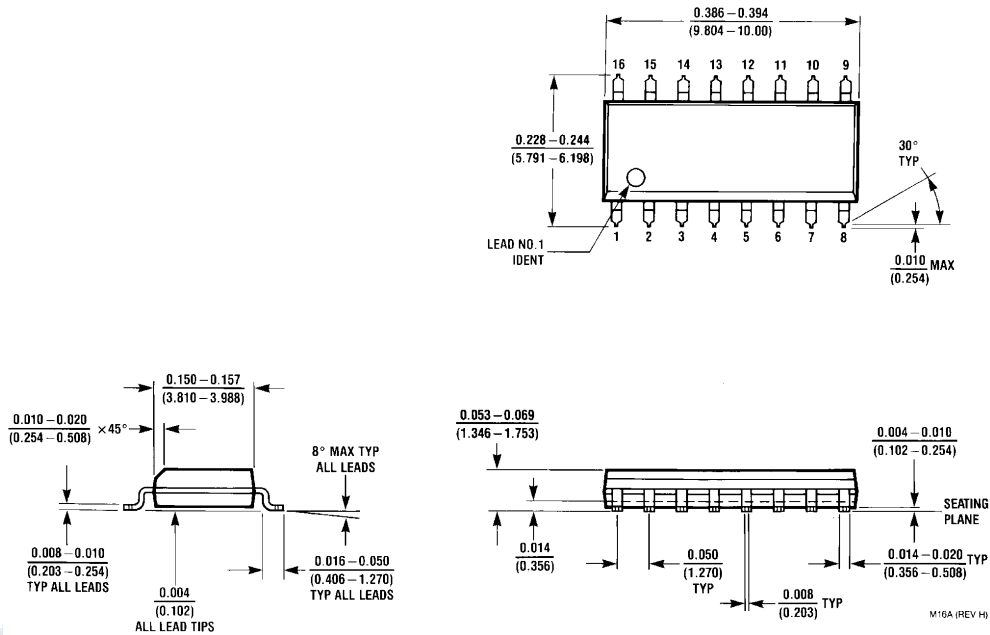

**16-Lead Small Outline Integrated Circuit (SOIC), JEDEC MS-012, 0.150 Narrow  
Package Number M16A**

*Electrónica S.A. de C.V.*

DM74LS151

**Physical Dimensions** inches (millimeters) unless otherwise noted (Continued)

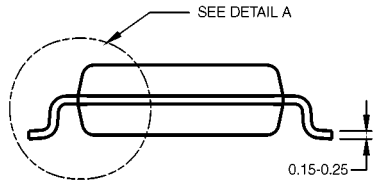
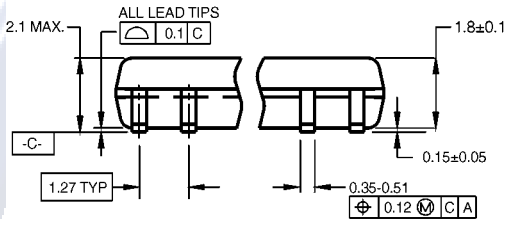
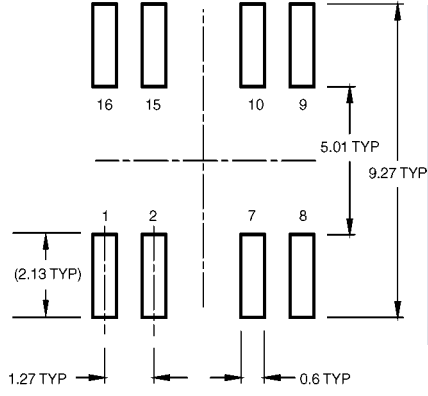
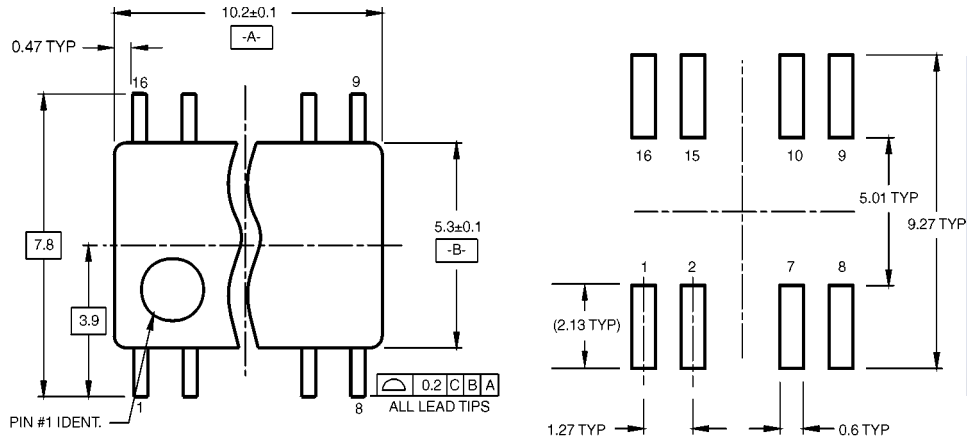

DIMENSIONS ARE IN MILLIMETERS

- NOTES:  
 A. CONFORMS TO EIAJ EDR-7320 REGISTRATION, ESTABLISHED IN DECEMBER, 1998.  
 B. DIMENSIONS ARE IN MILLIMETERS.  
 C. DIMENSIONS ARE EXCLUSIVE OF BURRS, MOLD FLASH, AND TIE BAR EXTRUSIONS.

M16DRRevB1

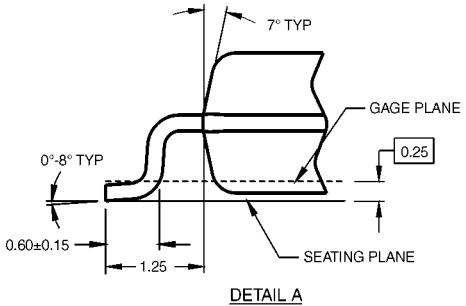

**16-Lead Small Outline Package (SOP), EIAJ TYPE II, 5.3mm Wide Package Number M16D**

### Physical Dimensions inches (millimeters) unless otherwise noted (Continued)

**16-Lead Plastic Dual-In-Line Package (PDIP), JEDEC MS-001, 0.300 Wide Package Number N16E**

N16E (REV F)

DM74LS151 1-of-8 Line Data Selector/Multiplexer

Electrónica S.A. de C.V.

Fairchild does not assume any responsibility for use of any circuitry described, no circuit patent licenses are implied and Fairchild reserves the right at any time without notice to change said circuitry and specifications.

**LIFE SUPPORT POLICY**

FAIRCHILD'S PRODUCTS ARE NOT AUTHORIZED FOR USE AS CRITICAL COMPONENTS IN LIFE SUPPORT DEVICES OR SYSTEMS WITHOUT THE EXPRESS WRITTEN APPROVAL OF THE PRESIDENT OF FAIRCHILD SEMICONDUCTOR CORPORATION. As used herein:

1. Life support devices or systems are devices or systems which, (a) are intended for surgical implant into the body, or (b) support or sustain life, and (c) whose failure to perform when properly used in accordance with instructions for use provided in the labeling, can be reasonably expected to result in a significant injury to the user.
2. A critical component in any component of a life support device or system whose failure to perform can be reasonably expected to cause the failure of the life support device or system, or to affect its safety or effectiveness.

[www.fairchildsemi.com](http://www.fairchildsemi.com)