



BTA/BTB24, BTA25, BTA26 and T25 Series

SNUBBERLESS™ & STANDARD

25A TRIACs

MAIN FEATURES:

Symbol	Value	Unit
$I_{T(RMS)}$	25	A
V_{DRM}/V_{RRM}	600 and 800	V
$I_{GT}(Q_1)$	35 to 50	mA

DESCRIPTION

Available either in through-hole or surface and T25 mount packages, the BTA/BTB24-25-26 triac series is suitable for general purpose AC power switching. They can be used as an ON/OFF function in applications such as static relays, heating regulation, water heaters, induction motor starting circuits...or for phase control operation in high power motor speed controllers, soft start circuits...The snubberless versions (BTA/BTB...W and T25 series) are specially recommended for use on inductive loads, thanks to their high commutation performances.

By using an internal ceramic pad, the BTA series provides voltage insulated tab (rated at 2500V RMS) complying with UL standards (File ref.: E81734).

ABSOLUTE MAXIMUM RATINGS

Symbol	Parameter	Value	Unit	
$I_{T(RMS)}$	RMS on-state current (full sine wave)	D PAK TO-220AB $T_c = 100^\circ\text{C}$	25	A
		RD91 TOP3 Ins. $T_c = 90^\circ\text{C}$		
		TO-220AB Ins. $T_c = 75^\circ\text{C}$		
I_{TSM}	Non repetitive surge peak on-state current (full cycle, T_j initial = 25°C)	F = 60 Hz t = 16.7 ms	260	A
		F = 50 Hz t = 20 ms	250	
I_t	I_t Value for fusing	tp = 10 ms	340	A s
dI/dt	Critical rate of rise of on-state current $I_G = 2 \times I_{GT}$, tr ≤ 100 ns	F = 120 Hz $T_j = 125^\circ\text{C}$	50	A/μs
V_{DSM}/V_{RSM}	Non repetitive surge peak off-state voltage	tp = 10 ms $T_j = 25^\circ\text{C}$	$V_{DRM}/V_{RRM} + 100$	V
I_{GM}	Peak gate current	tp = 20 μs $T_j = 125^\circ\text{C}$	4	A
$P_{G(AV)}$	Average gate power dissipation	$T_j = 125^\circ\text{C}$	1	W
T_{stg} T_j	Storage junction temperature range Operating junction temperature range		- 40 to + 150 - 40 to + 125	$^\circ\text{C}$

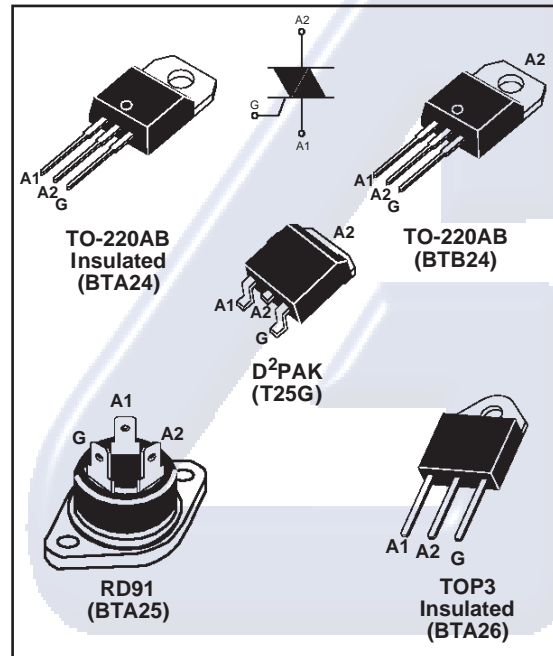

BTA/BTB24, BTA25, BTA26 and T25 Series

ELECTRICAL CHARACTERISTICS (T_j = 25°C, unless otherwise specified)

■ SNUBBERLESS™ (3 Quadrants) T25-G, BTA/BTB24...W, BTA25...W, BTA26...W

Symbol	Test Conditions	Quadrant		T25	BTA/BTB		Unit
				T2535	CW	BW	
I _{GT} (1)	V _D = 12 V R _L = 33 Ω	I - II - III	MAX.	35	35	50	mA
V _{GT}		I - II - III	MAX.	1.3			V
V _{GD}	V _D = V _{DRM} R _L = 3.3 kΩ T _j = 125°C	I - II - III	MIN.	0.2			V
I _H (2)	I _T = 500 mA		MAX.	50	50	75	mA
I _L	I _G = 1.2 I _{GT}	I - III	MAX.	70	70	80	mA
		II		80	80	100	
dV/dt (2)	V _D = 67 % V _{DRM} gate open T _j = 125°C		MIN.	500	500	1000	V/μs
(dl/dt) _c (2)	Without snubber T _j = 125°C		MIN.	13	13	22	A/ms

■ STANDARD (4 Quadrants): BTA25...B, BTA26...B

Symbol	Test Conditions	Quadrant		Value	Unit
I _{GT} (1)	V _D = 12 V R _L = 33 Ω	I - II - III IV	MAX.	50 100	mA
V _{GT}		ALL	MAX.	1.3	V
V _{GD}	V _D = V _{DRM} R _L = 3.3 kΩ T _j = 125°C	ALL	MIN.	0.2	V
I _H (2)	I _T = 500 mA		MAX.	80	mA
I _L	I _G = 1.2 I _{GT}	I - III - IV	MAX.	70	mA
		II		160	
dV/dt (2)	V _D = 67 % V _{DRM} gate open T _j = 125°C		MIN.	500	V/μs
(dV/dt) _c (2)	(dl/dt) _c = 13.3 A/ms T _j = 125°C		MIN.	10	V/μs

STATIC CHARACTERISTICS

Symbol	Test Conditions		Value	Unit
V _{TM} (2)	I _{TM} = 35 A t _p = 380 μs	T _j = 25°C	MAX.	1.55 V
V _{to} (2)	Threshold voltage	T _j = 125°C	MAX.	0.85 V
R _d (2)	Dynamic resistance	T _j = 125°C	MAX.	16 mΩ
I _{DRM}	V _{DRM} = V _{RPM}	T _j = 25°C	MAX.	5 μA
I _{RPM}		T _j = 125°C		3 mA

Note 1: minimum IGT is guaranteed at 5% of IGT max.

Note 2: for both polarities of A2 referenced to A1

BTA/BTB24, BTA25, BTA26 and T25 Series

THERMAL RESISTANCES

Symbol	Parameter		Value	Unit	
R _{th(j-c)}	Junction to case (AC)	D PAK TO-220AB	0.8	°C/W	
		RD91 (Insulated) TOP3 Insulated	1.1		
		TO-220AB Insulated	1.7		
R _{th(j-a)}	Junction to ambient	S = 1 cm	D PAK	°C/W	
			TOP3 Insulated		50
			TO-220AB		60
			TO-220AB Insulated		

S: Copper surface under tab

PRODUCT SELECTOR

Part Number	Voltage (xxx)		Sensitivity	Type	Package
	600 V	800 V			
BTA/BTB24-xxxBW	X	X	50 mA	Snubberless	TO-220AB
BTA/BTB24-xxxCW	X	X	35 mA	Snubberless	TO-220AB
BTA25-xxxB	X	X	50 mA	Standard	RD-91
BTA25-xxxBW	X	X	50 mA	Snubberless	RD-91
BTA25-xxxCW	X	X	35 mA	Snubberless	RD-91
BTA26-xxxB	X	X	50 mA	Standard	TOP3 Ins.
BTA26-xxxBW	X	X	50 mA	Snubberless	TOP3 Ins.
BTA26-xxxCW	X	X	35 mA	Snubberless	TOP3 Ins.
T2535-xxxG	X	X	35 mA	Snubberless	D PAK

BTB: Non insulated TO-220AB package

ORDERING INFORMATION

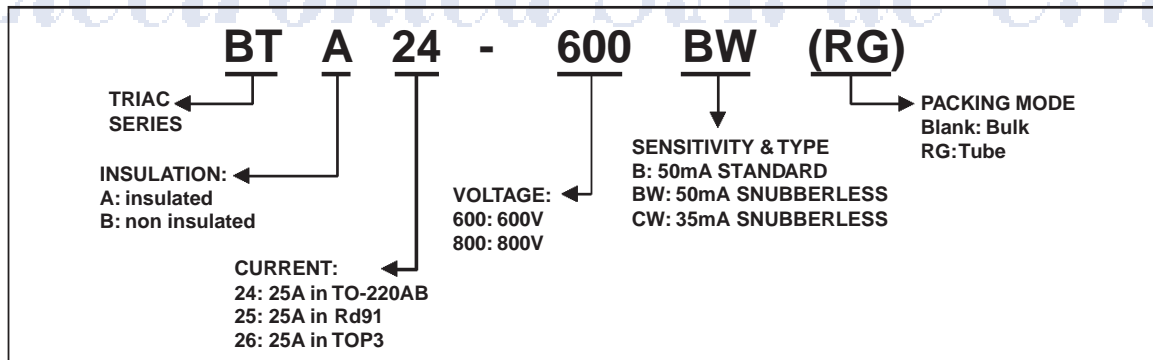

BTA/BTB24, BTA25, BTA26 and T25 Series

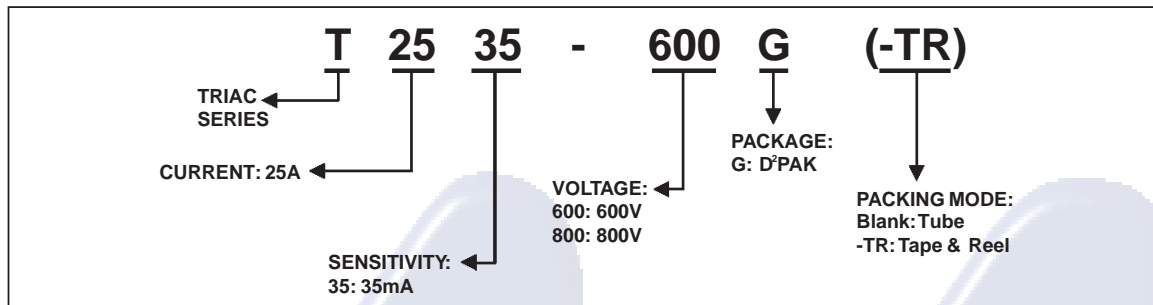

OTHER INFORMATION

Part Number	Marking	Weight	Base quantity	Packing mode
BTA/BTB24-xxxxyz	BTA/BTB24xxxxyz	2.3 g	250	Bulk
BTA/BTB24-xxxxyzRG	BTA/BTB24-xxxxyz	2.3 g	50	Tube
BTA25-xxxxyz	BTA25xxxxyz	20 g	25	Bulk
BTA26-xxxxyz	BTA26xxxxyz	4.5 g	120	Bulk
T2535-xxxG	T2535xxxG	1.5 g	50	Tube
T2535-xxxG-TR	T2535xxxG	1.5 g	1000	Tape & reel

Note: xxx= voltage, y = sensitivity, z = type

Electrónica S.A. de C.V.



BTA/BTB24, BTA25, BTA26 and T25 Series

Fig. 1: Maximum power dissipation versus RMS on-state current (full cycle).

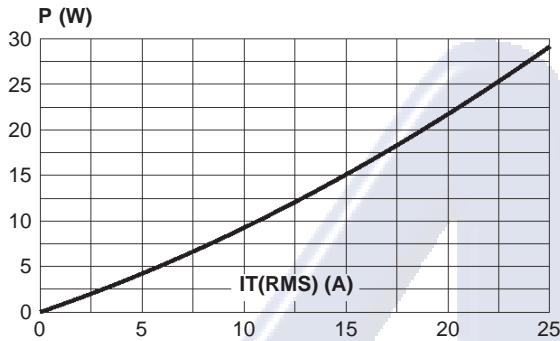

Fig. 2-1: RMS on-state current versus case temperature (full cycle).

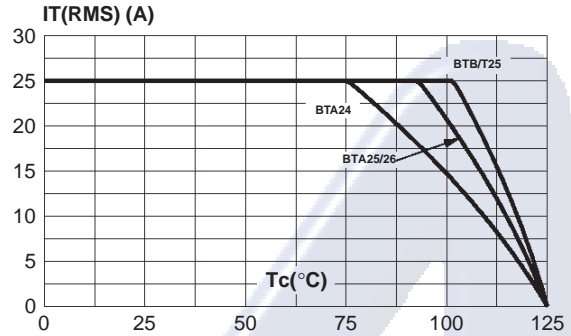

Fig. 2-2: D PAK RMS on-state current versus ambient temperature (printed circuit board FR4, copper thickness: 35 μ m), full cycle.

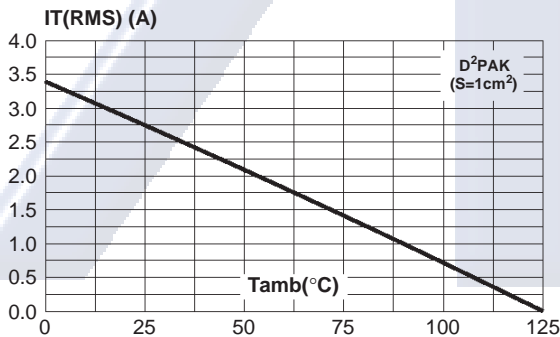

Fig. 3: Relative variation of thermal impedance versus pulse duration.

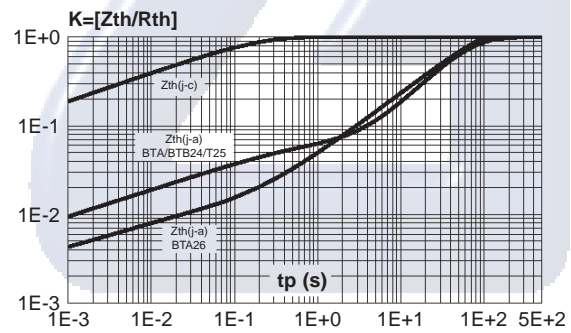

Fig. 4: On-state characteristics (maximum values).

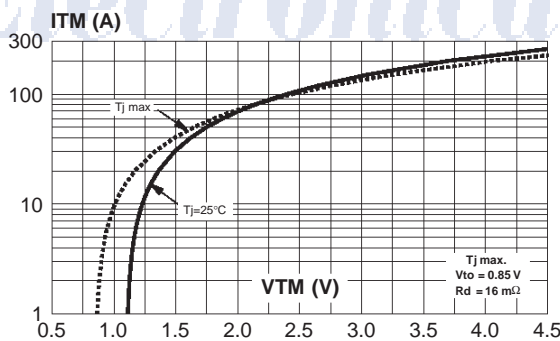
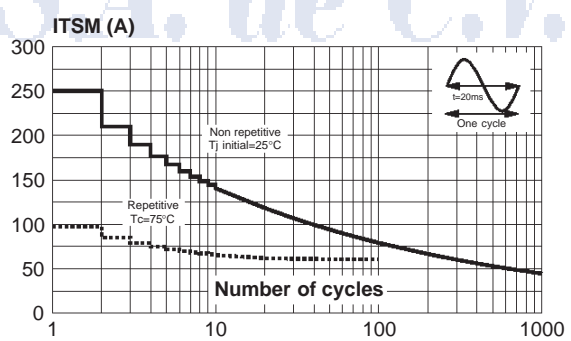

Fig. 5: Surge peak on-state current versus number of cycles.



BTA/BTB24, BTA25, BTA26 and T25 Series

Fig. 6: Non-repetitive surge peak on-state current for a sinusoidal pulse with width $t_p < 10\text{ms}$, and corresponding value of I_t .

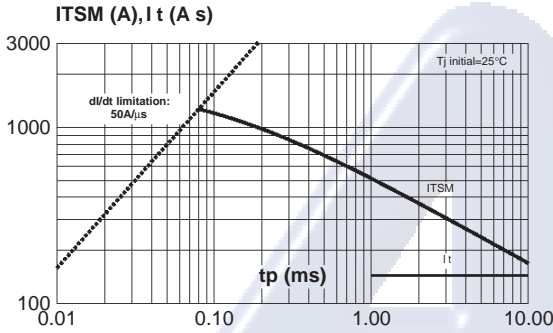

Fig. 8: Relative variation of critical rate of decrease of main current versus $(dV/dt)_c$ (typical values).

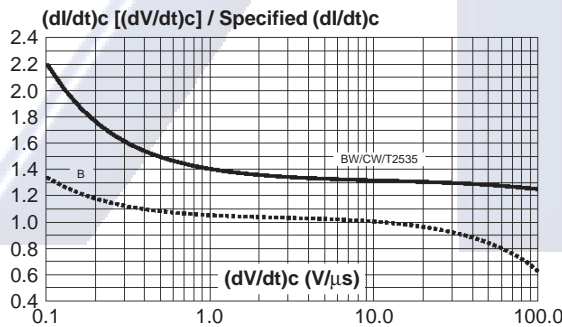

Fig. 7: Relative variation of gate trigger current, holding current and latching current versus junction temperature (typical values).

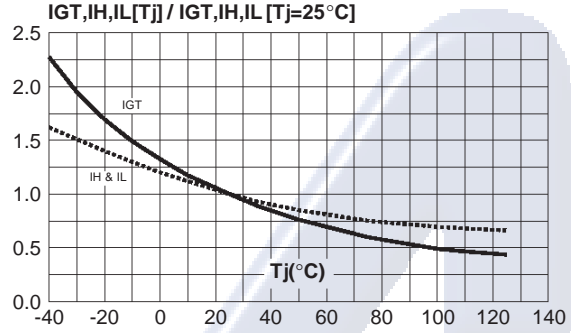

Fig. 9: Relative variation of critical rate of decrease of main current versus junction temperature.

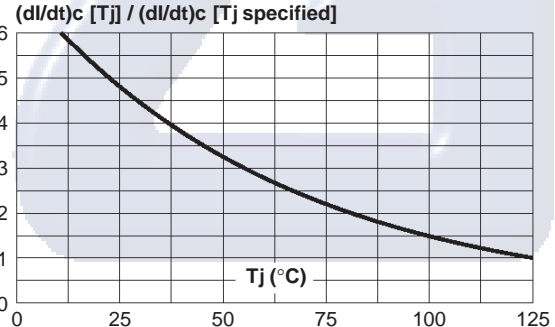
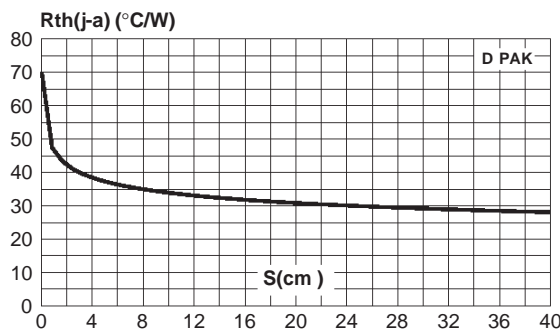

Fig. 10: D PAK Thermal resistance junction to ambient versus copper surface under tab (printed circuit board FR4, copper thickness: 35 μm).



BTA/BTB24, BTA25, BTA26 and T25 Series

PACKAGE MECHANICAL DATA

D PAK (Plastic)

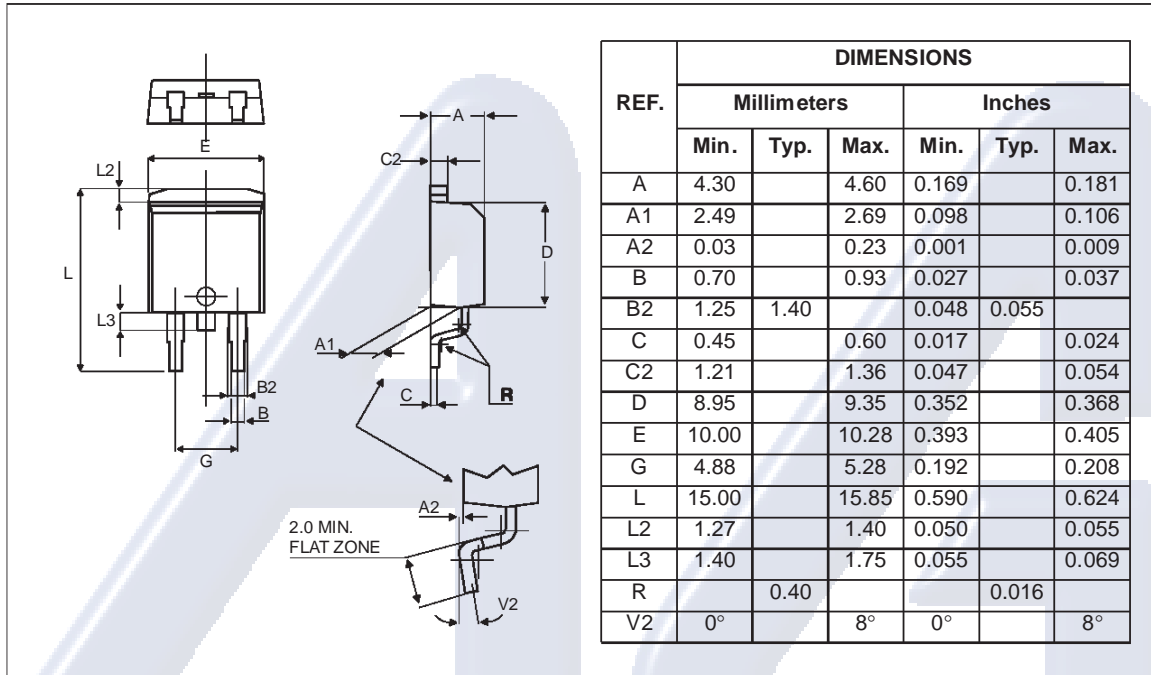

FOOTPRINT DIMENSIONS (in millimeters)

D PAK (Plastic)

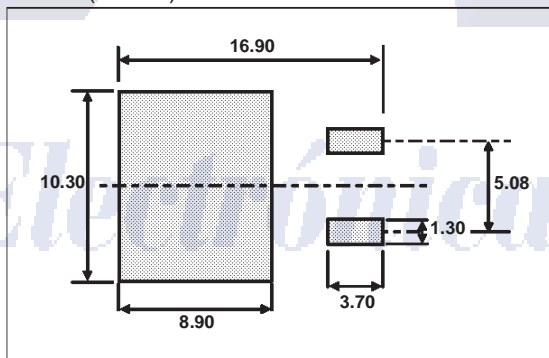

BTA/BTB24, BTA25, BTA26 and T25 Series

PACKAGE MECHANICAL DATA

RD91 (Plastic)

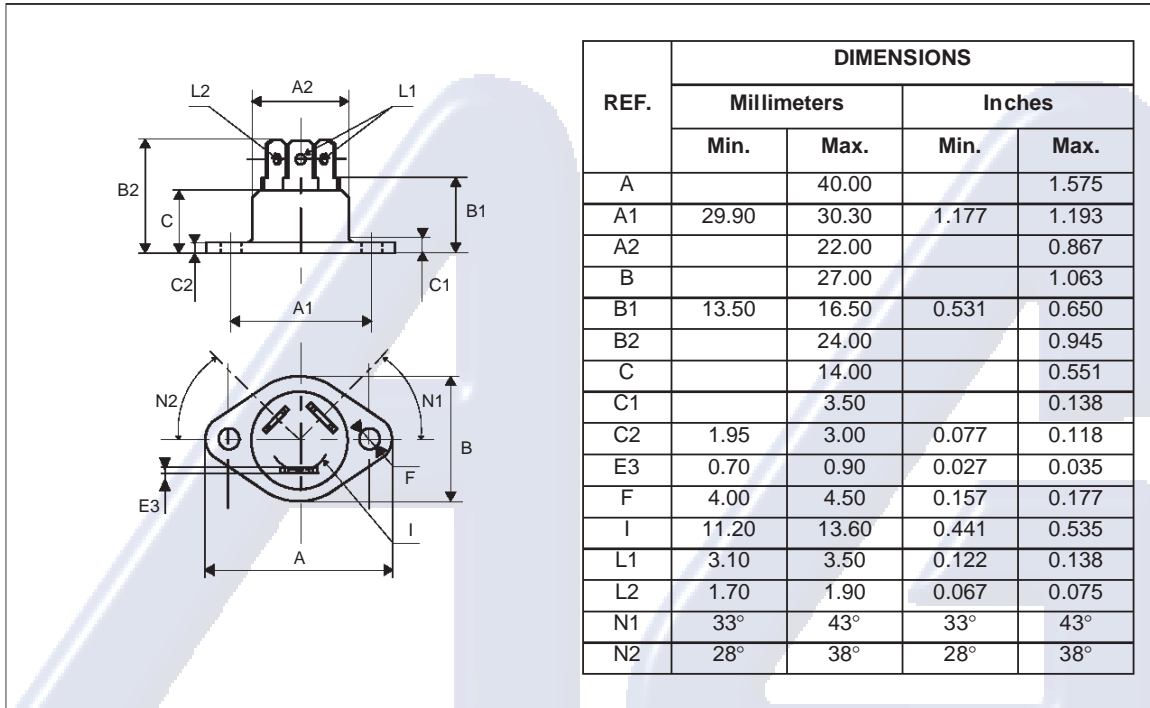

PACKAGE MECHANICAL DATA

TOP3 (Plastic)

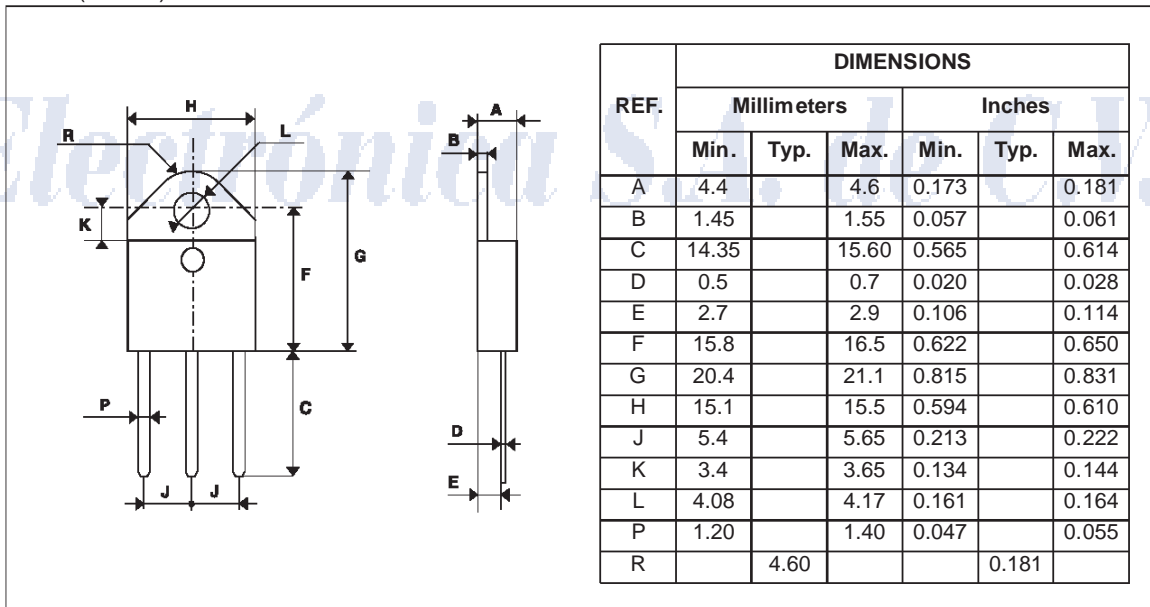

BTA/BTB24, BTA25, BTA26 and T25 Series

PACKAGE MECHANICAL DATA

TO-220AB (Plastic)

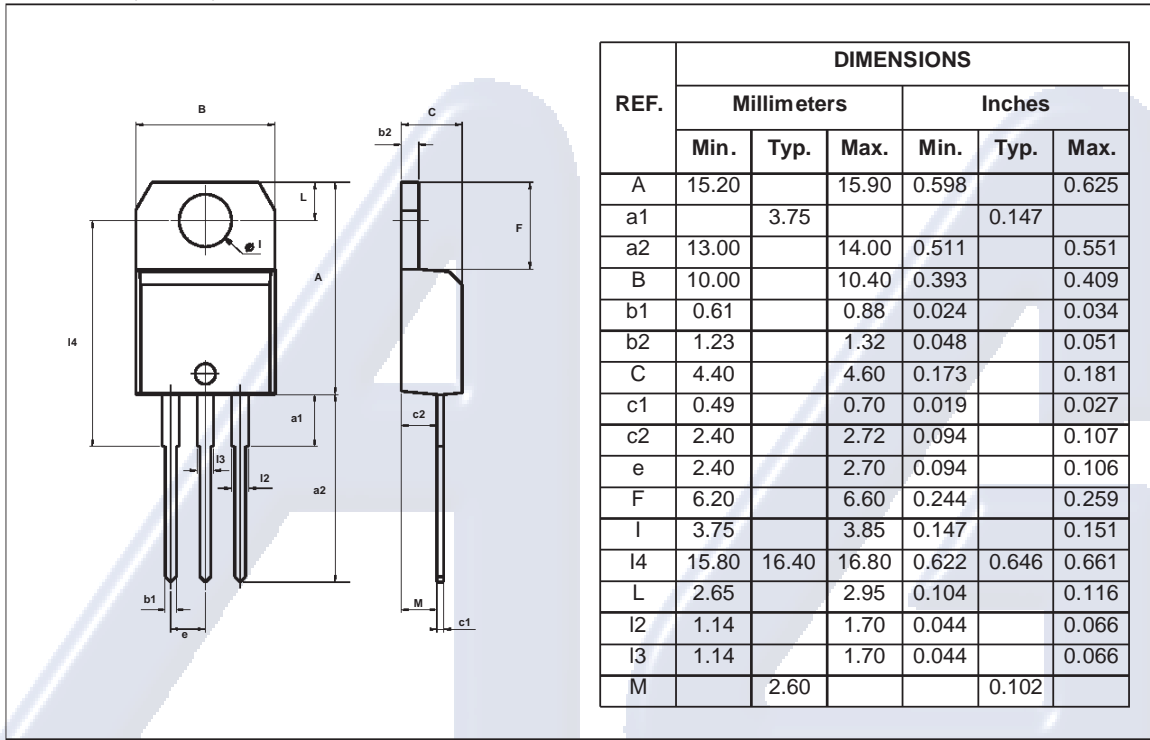

Electrónica S.A. de C.V.

Information furnished is believed to be accurate and reliable. However, STMicroelectronics assumes no responsibility for the consequences of use of such information nor for any infringement of patents or other rights of third parties which may result from its use. No license is granted by implication or otherwise under any patent or patent rights of STMicroelectronics. Specifications mentioned in this publication are subject to change without notice. This publication supersedes and replaces all information previously supplied. STMicroelectronics products are not authorized for use as critical components in life support devices or systems without express written approval of STMicroelectronics.

© The ST logo is a registered trademark of STMicroelectronics

© 2002 STMicroelectronics - Printed in Italy - All Rights Reserved

STMicroelectronics GROUP OF COMPANIES

Australia - Brazil - Canada - China - Finland - France - Germany
Hong Kong - India - Israel - Italy - Japan - Malaysia - Malta - Morocco - Singapore
Spain - Sweden - Switzerland - United Kingdom - United States.

<http://www.st.com>

