

SPECIFICATION

Product Name: NDIR CO₂ Sensor Module

Item No.: CM1106H-NS

Version: V0.4

Date: May 26, 2020

Revision

No.	Version	Content	Date
1	V0.1	Issue the high-end version CM1106H-NS	2019.04.01
2	V0.2	Revise information of range, ABC calibration, and dimension picture	2019.07.12
3	V0.3	Add range note for accuracy	2019.11.22
4	V0.4	Revise the power supply, description of ABC cycle and drawing	2020.05.26

NDIR CO₂ Sensor Module

CM1106H-NS



Applications

- HVAC industry
- IAQ monitor
- Air purifier
- Automotive
- IoT devices
- Plant growth

Description

Infrared carbon dioxide CO₂ sensor CM1106H-NS can be used to detect CO₂ concentration of indoor air by adopting advanced non-dispersive infrared technology (NDIR). It is widely used in ventilation system, air conditioner, air purifier, IAQ monitor, agriculture, plant cultivation and cold-chain, etc.

Features

- NDIR technology with independent intellectual property
- Temperature calibration within whole measurement range
- Long life span, auto-calibration, maintenance free
- Small size and compact structure, easy to install

Working Principle

The main components of an NDIR CO₂ sensor are an infrared source, a sample chamber, a filter and an infrared detector. The infrared light is directed by the infrared source passing through the gas chamber towards the detector.

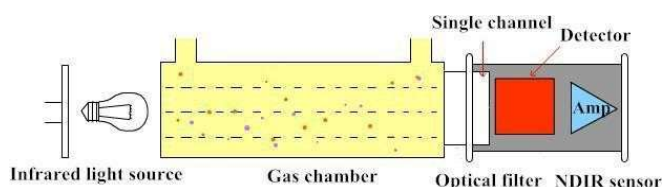

CO₂ molecules inside the gas chamber will only absorb a specific wavelength of the light. The filter allows only the specific wavelength corresponded to pass through it. The detector measures the intensity of infrared light that is related to the intensity of CO₂ and can be described through the Lambert-Beer's Law. The change in sensor signal reflects the change in gas concentration.

Specifications

Single Beam NDIR CO ₂ Sensor Specification	
Target gas	Carbon dioxide (CO ₂)
Operating principle	Non-dispersive infrared (NDIR)
Measurement range	PWM: 0-2000ppm UART:0-10000ppm (Note 1)
Working temperature	-10°C ~ 50°C
Working humidity	0-95%RH (non-condensing)
Storage temperature	-30°C ~ 70°C
Storage humidity	0-95%RH (non-condensing)
Accuracy	± (30ppm+3% of reading) @ -10°C~50°C ,0-85%RH,UART/PWM 0-2000ppm (Note 2 and 3)
Sampling frequency	1s
Time to first reading	30s
Power supply	DC 4.5V-5.5V
Ripple wave	<50mV
Working current	<50mA
Dimensions	33x19.7x8.9mm (pin is not included)
Weight	5g
Signal output	UART_TTL PWM
Life span	≥15 years
Maintenance	Maintenance-free for normal indoor application with Auto-calibration

Note 1: Sensor is designed to measure in the range 0~2000ppm (PWM), 0-10000ppm (UART) with specified in the table. Nevertheless exposure to concentrations below 400ppm may result in incorrect operation of ABC algorithm and shall be avoided for model with ABC ON.

Note 2: In normal IAQ applications, accuracy is defined after minimum three (3) ABC periods of continuous operation with ABC on. Some industrial applications do require maintenance. Contact Cubic for further information.

Note 3: Specification is referenced to certified calibration mixtures. Uncertainty of calibration gas mixtures (±2% currently) is to be added to the specified accuracy for absolute measurement.

Dimensions and Connector

1. Dimensions (Unit mm, tolerance ± 0.2 mm)

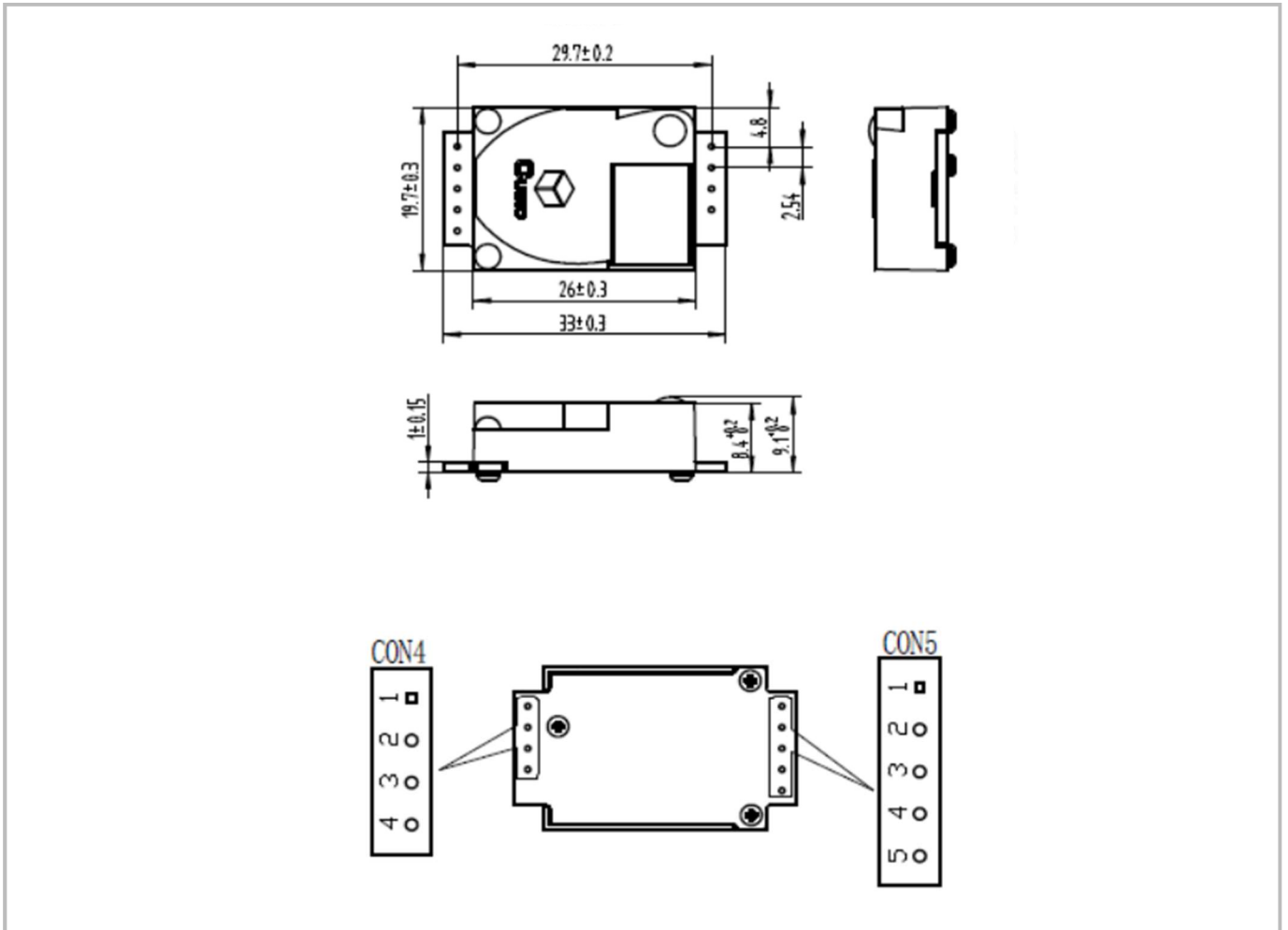

2. I/O Connector Pinout

CON4			CON5		
Pin	Name	Description	Pin	Name	Description
1	+5V	Power supply input (4.5V-5.5V)	1	+3.3	Power supply output (3.3V/100mA)
2	GND	Power supply input (GND)	2	RX	UART receiving (3.3V TTL)
3	A	Alarming (Reserved)	3	TX	UART sending (3.3V TTL)
4	PWM	PWM output	4	R/T	RS485 control site (Reserved)
			5	CA	Manual calibration

Typical Application Circuit

Case1. (1) UART_TTL 3.3V output

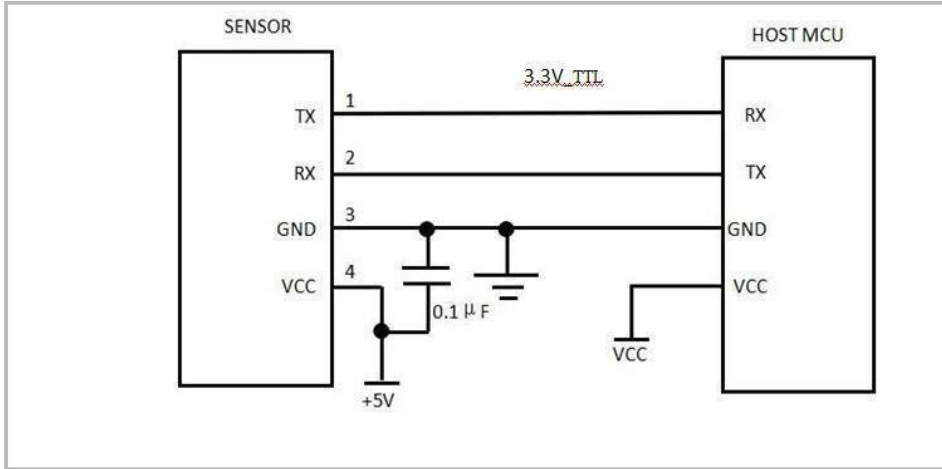

(2) PWM output

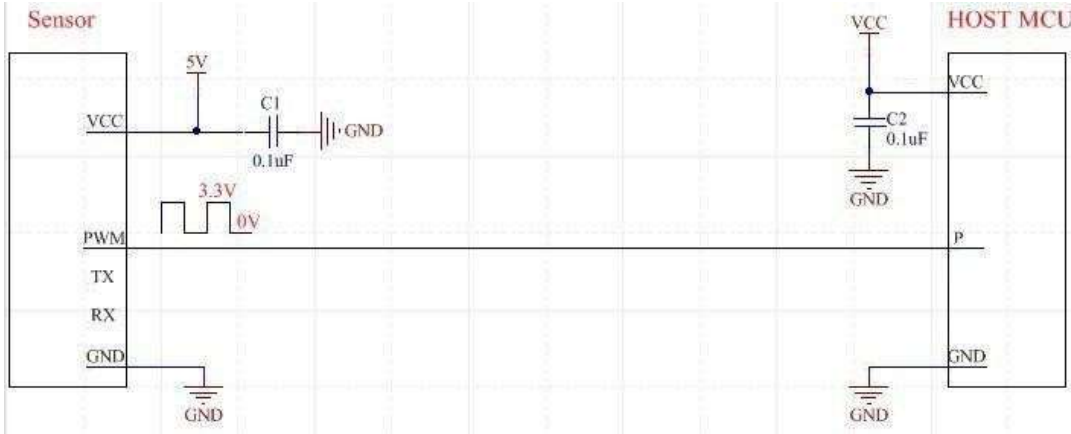

Case2. 5V level and 3.3V level conversion circuit

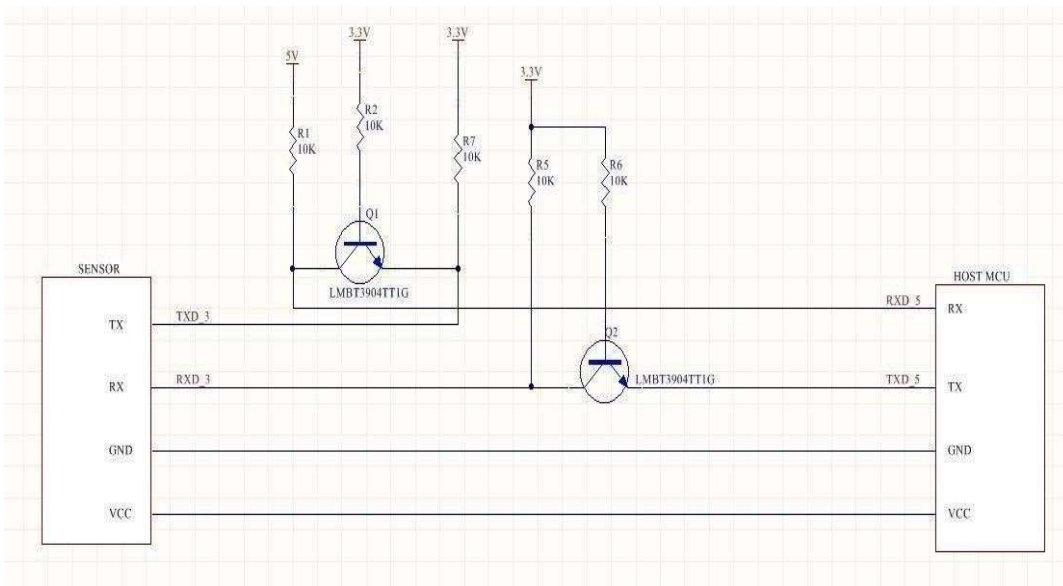

Description of Calibration

Auto Calibration:

Rough installing and influence of transportation might result in reducing of sensor measuring accuracy and baseline drift, sensor will correct the drift by the built-in self-correcting logic, and the auto baseline correction period is 24h+7 days. Powering on the sensor for 24 hours continuously, it will record the lowest CO2 concentration measurement value during the 24 hours, which will be regarded as baseline (400ppm) when sensor do auto calibration after the 24 hours working, and then the sensor will enter regular 7 days correction cycle, auto calibration will be implemented every 7 days. In order to ensure correct auto calibration, please make sure working environment of the sensor can reach to outdoor fresh air level (400ppm) during the 24 hours and regular 7 days auto baseline correction cycle.

Note: Please contact with Cubic for more detailed auto calibration strategy.

Manual Calibration:

Rough installing and influence of transportation might result in reducing of sensor measuring accuracy and baseline drift. If need to recover accuracy quickly after installing, users can do manual calibration. Put the sensor in the environment where the CO2 concentration level can reach 400ppm, and the CO2 concentration in this environment and the reading of CO2 sensor should be stable before calibration. And then users can do manual calibration by sending command, please refer to the communication protocol for more details.

PWM and Alarm Output

PWM cycle: 1ms

Positive pulse width: PPM/2000

CO2 level measurement: (PWM positive pulse width)

*2000 PWM output schema:

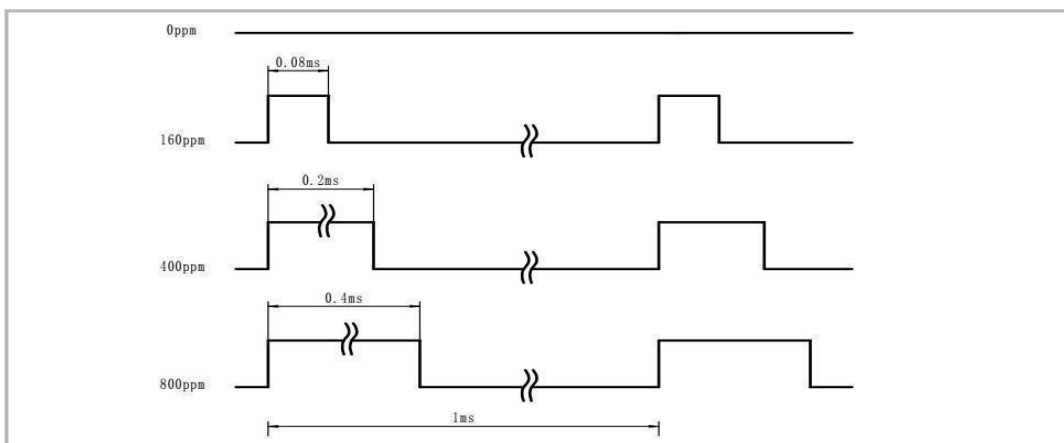

UART Communication Protocol

1. General statement

- (1) Baud rate: 9600, Data Bits: 8, Stop Bits: 1, Parity: No, Flow Control: No
- (2) The data of this protocol are all hexadecimal data. For example, "46" is decimal[70];
- (3) [xx] is single-byte data (unsigned, 0-255); double-byte data high byte first, low byte last;

2. UART protocol format

Sending format of upper computer

Start Symbol	Length	Command	Data 1	...	Data n.	Check Sum
HEAD	LEN	CMD	DATA1	DATAn	CS
11H	XXH	XXH	XXH	XXH	XXH

Detail description on protocol format

Protocol Format	Description
Start Symbol	Sending by upper computer is fixed as [11H], module respond is fixed as [16H]
Length	Length of frame bytes= data length +1 (including CMD+DATA)
Command	Command
Data	Data of writing or reading, length is not fixed
Check Sum	Cumulative sum of data = 256-(HEAD+LEN+CMD+DATA)%256

3. Command Table of Serial Protocol

Item No.	Function Name	Command
1	Read CO2 measurement results	0x01
2	CO2 concentration value single point calibration	0x03
3	Read module firmware version number	0x1E
4	Open/close ABC and set ABC parameter	0x10
5	Read the serial number of the sensor	0x1F
6	Instruction stores a set of calibrated raw data	0x51

4. Detail Description of UART Protocol

4.1 Read Measured Result of CO₂

Send: 11 01 01 ED

Response: 16 05 01 DF1- DF4 [CS]

Function: Read measured result of CO₂ (Unit: ppm)

Note: CO₂ measured result = DF1*256 + DF2

Example:

Response: 16 05 01 02 58 00 00 8A

Explanation:

Hex is converted to decimal: 02 is 02; 58 is 88

CO₂ concentration=02*256+88 = 600ppm

4.2 CO₂ concentration value single point calibration

Send: 11 03 03 DF1 DF2 CS

Response: 16 01 03 E6

Function: CO₂ concentration value single point calibration

Note:

1. Single point calibration target value = DF1*256 + DF2. The unit is in ppm and the range is (400 to 1500 ppm)
2. Before performing CO₂ single point calibration, please confirm that the current environment CO₂ value is the single point calibration target value, and the stabilization time is at least 2 minutes.

Example:

When module single point needs to be calibrated to 600ppm, send the command: 11 03 03 02

58 8F Hexadecimal conversion to decimal: 02 is 02; 58 is 88

CO₂ measurement = 02*256 + 88=600ppm

4.3 Read module firmware version number

Send: 11 01 1E D0

Response: 16 [x+1] 1E [CH1] [CH2] [CH3][CHx] CS

Function: Read module firmware version number

Note: [x+1] is the length of the byte; [CHx] is the version number of the software, which is ASCII code.

Example:

When the sensor version is CM V0.0.20 时 , response data as follows: Convert hexadecimal to ASCII code:

Note: when 20 converted to ASCII code, it equals to blank space

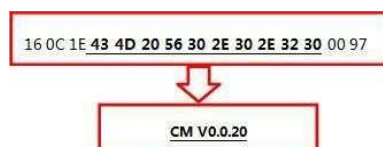

4.3 Open/close ABC and set ABC parameter

Send: 11 07 10 DF1 DF2 DF3 DF4 DF5 DF6 CS

Response: 16 01 10 D9

Explanation:

Character	Note
DF1	Reserved (default 100)
DF2	Open/close auto calibration (0: open; 2: close)
DF3	Calibration cycle (1~30 days optional, default is 7 days)
DF4	High base value (8 bytes)
DF5	Low base value (8bytes)
DF6	Reserved (Default is 100)

Note: DF4 and DF5 default value is 400, that is DF4: 01; DF5: 90

4.41 Open ABC and set calibration cycle

Send: 11 07 10 64 00 07 01 90 64 78

Response: 16 01 10 D9

4.42 Close ABC

Send: 11 07 10 64 02 07 01 90 64 76

Response: 16 01 10 D9

4.5 Read the serial number of the sensor

Send: 11 01 1F CF

Response: 16 0B 1F (SN1) (SN2) (SN3) (SN4) (SN5) [CS]

Function: Read the serial number of the sensor

Note: Read the serial number of the sensor. SNn: 0~9999, 5 integer form 20-digit

Packing Information

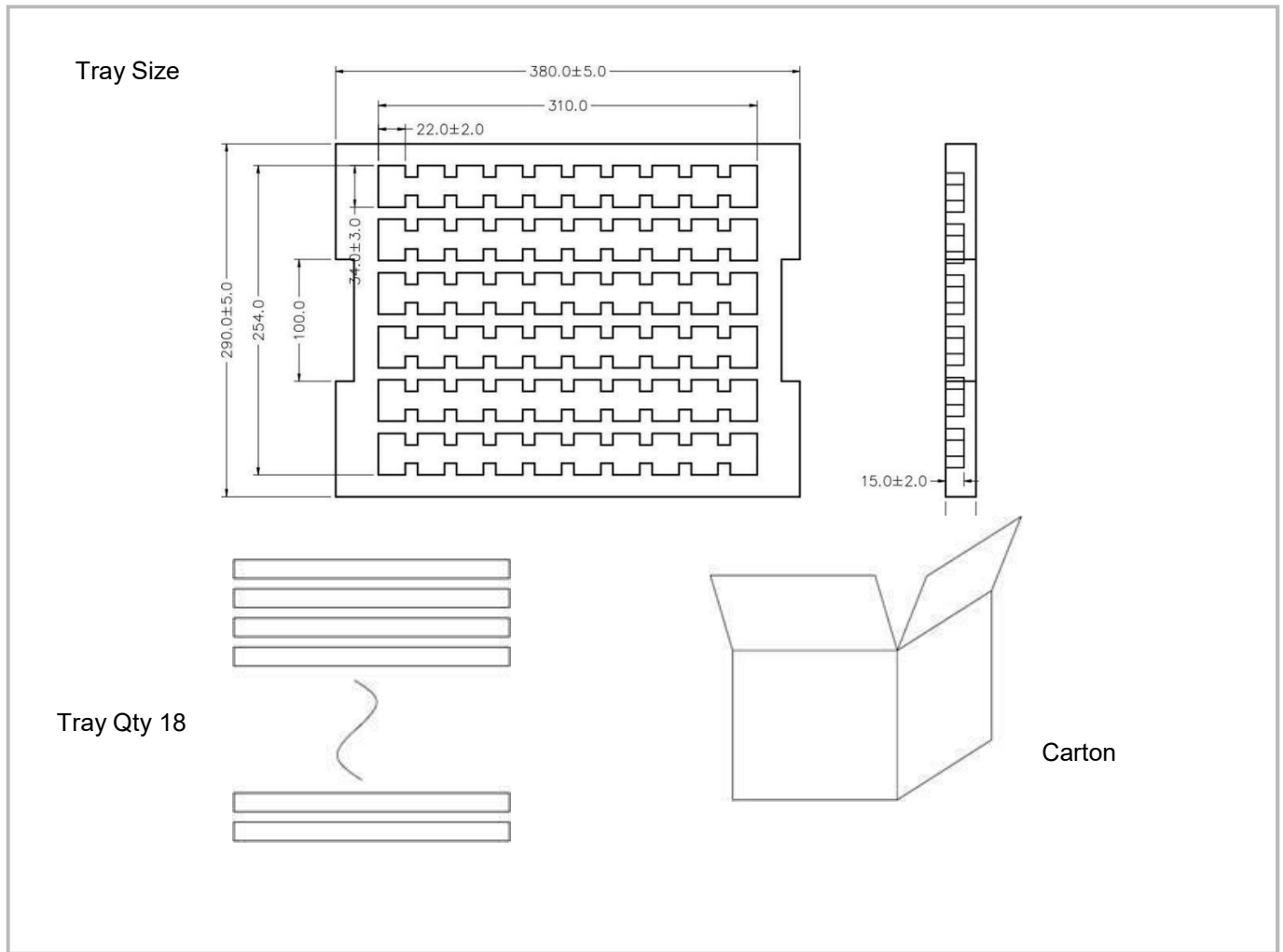

Sensor per Tray	Tray Qty	Sensor per	Carton Dimensions	Packing Material
60 pcs	18 layers	1080 pcs	395*310*480 mm	Red anti-static EPE

After-Sales Services and Consultancy

Cubic Sensor and Instrument Co., Ltd.

Tel: +86 (0)27 81628827 Fax: +86 (0)27 81628821

Add: Fenghuang No.3 Road, Fenghuang Industrial Park, Eastlake Hi-tech
Development Zone, Wuhan 430205, China

E-mail: info@gassensor.com.cn