

HD74HC32

Quad. 2-input OR Gates

REJ03D0545-0200
 (Previous ADE-205-417)
 Rev.2.00
 Oct 06, 2005

Features

- High Speed Operation: $t_{pd} = 10 \text{ ns typ (} C_L = 50 \text{ pF)}$
- High Output Current: Fanout of 10 LSTTL Loads
- Wide Operating Voltage: $V_{CC} = 2 \text{ to } 6 \text{ V}$
- Low Input Current: $1 \mu\text{A max}$
- Low Quiescent Supply Current: $I_{CC} \text{ (static)} = 1 \mu\text{A max (} T_a = 25^\circ\text{C)}$
- Ordering Information

Part Name	Package Type	Package Code (Previous Code)	Package Abbreviation	Taping Abbreviation (Quantity)
HD74HC32P	DILP-14 pin	PRDP0014AB-B (DP-14AV)	P	—
HD74HC32FPEL	SOP-14 pin (JEITA)	PRSP0014DF-B (FP-14DAV)	FP	EL (2,000 pcs/reel)
HD74HC32RPEL	SOP-14 pin (JEDEC)	PRSP0014DE-A (FP-14DNV)	RP	EL (2,500 pcs/reel)
HD74HC32TELL	TSSOP-14 pin	PTSP0014JA-B (TTP-14DV)	T	ELL (2,000 pcs/reel)

Note: Please consult the sales office for the above package availability.

Function Table

Inputs		Output
A	B	Y
L	L	L
H	L	H
L	H	H
H	H	H

H : High level

L : Low level

Pin Arrangement

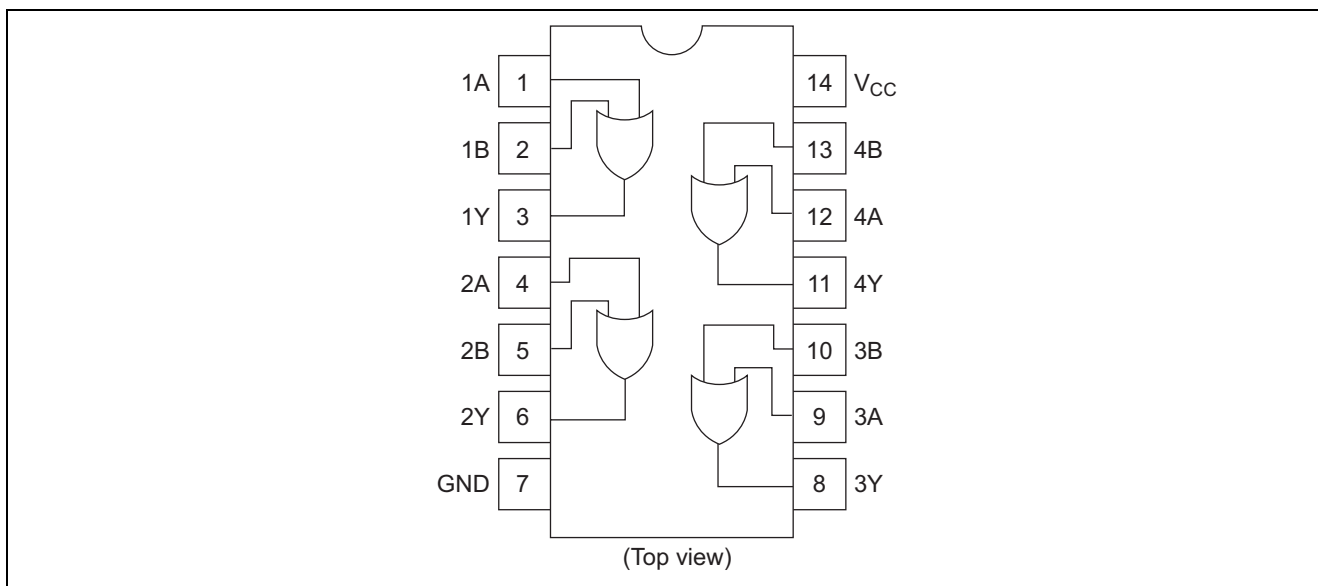

Absolute Maximum Ratings

Item	Symbol	Ratings	Unit
Supply voltage range	V_{CC}	-0.5 to 7.0	V
Input / Output voltage	V_{in}, V_{out}	-0.5 to $V_{CC} + 0.5$	V
Input / Output diode current	I_{IK}, I_{OK}	± 20	mA
Output current	I_o	± 25	mA
V_{CC}, GND current	I_{CC} or I_{GND}	± 50	mA
Power dissipation	P_T	500	mW
Storage temperature	T_{stg}	-65 to +150	$^{\circ}C$

Note: The absolute maximum ratings are values, which must not individually be exceeded, and furthermore, no two of which may be realized at the same time.

Recommended Operating Conditions

Item	Symbol	Ratings	Unit	Conditions
Supply voltage	V_{CC}	2 to 6	V	
Input / Output voltage	V_{IN}, V_{OUT}	0 to V_{CC}	V	
Operating temperature	T_a	-40 to 85	$^{\circ}C$	
Input rise / fall time ^{*1}	t_r, t_f	0 to 1000	ns	$V_{CC} = 2.0 V$
		0 to 500		$V_{CC} = 4.5 V$
		0 to 400		$V_{CC} = 6.0 V$

Note: 1. This item guarantees maximum limit when one input switches.
Waveform: Refer to test circuit of switching characteristics.

Electrical Characteristics

Item	Symbol	V _{CC} (V)	Ta = 25°C			Ta = -40 to +85°C		Unit	Test Conditions	
			Min	Typ	Max	Min	Max			
Input voltage	V _{IH}	2.0	1.5	—	—	1.5	—	V		
		4.5	3.15	—	—	3.15	—			
		6.0	4.2	—	—	4.2	—			
	V _{IL}	2.0	—	—	0.5	—	0.5	V		
		4.5	—	—	1.35	—	1.35			
		6.0	—	—	1.8	—	1.8			
Output voltage	V _{OH}	2.0	1.9	2.0	—	1.9	—	V	V _{in} = V _{IH} or V _{IL}	I _{OH} = -20 μA
		4.5	4.4	4.5	—	4.4	—			I _{OH} = -4 mA
		6.0	5.9	6.0	—	5.9	—			I _{OH} = -5.2 mA
		4.5	4.18	—	—	4.13	—			
		6.0	5.68	—	—	5.63	—			
		6.0	5.68	—	—	5.63	—			
	V _{OL}	2.0	—	0.0	0.1	—	0.1	V	V _{in} = V _{IH} or V _{IL}	I _{OL} = 20 μA
		4.5	—	0.0	0.1	—	0.1			
		6.0	—	0.0	0.1	—	0.1			
		4.5	—	—	0.26	—	0.33			I _{OL} = 4 mA
		6.0	—	—	0.26	—	0.33			I _{OL} = 5.2 mA
		6.0	—	—	0.26	—	0.33			
Input current	I _{in}	6.0	—	—	±0.1	—	±1.0	μA	V _{in} = V _{CC} or GND	
Quiescent supply current	I _{CC}	6.0	—	—	1.0	—	10	μA	V _{in} = V _{CC} or GND, I _{out} = 0 μA	

Switching Characteristics (C_L = 50 pF, Input t_r = t_f = 6 ns)

Item	Symbol	V _{CC} (V)	Ta = 25°C			Ta = -40 to +85°C		Unit	Test Conditions	
			Min	Typ	Max	Min	Max			
Propagation delay time	t _{PLH}	2.0	—	—	100	—	125	ns		
		4.5	—	10	20	—	25			
		6.0	—	—	17	—	21			
	t _{PHL}	2.0	—	—	100	—	125	ns		
		4.5	—	10	20	—	25			
		6.0	—	—	17	—	21			
Output rise time	t _{TLH}	2.0	—	—	75	—	95	ns		
		4.5	—	5	15	—	19			
		6.0	—	—	13	—	16			
Output fall time	t _{THL}	2.0	—	—	75	—	95	ns		
		4.5	—	5	15	—	19			
		6.0	—	—	13	—	16			
Input capacitance	C _{in}	—	—	5	10	—	10	pF		

Test Circuit



Waveforms

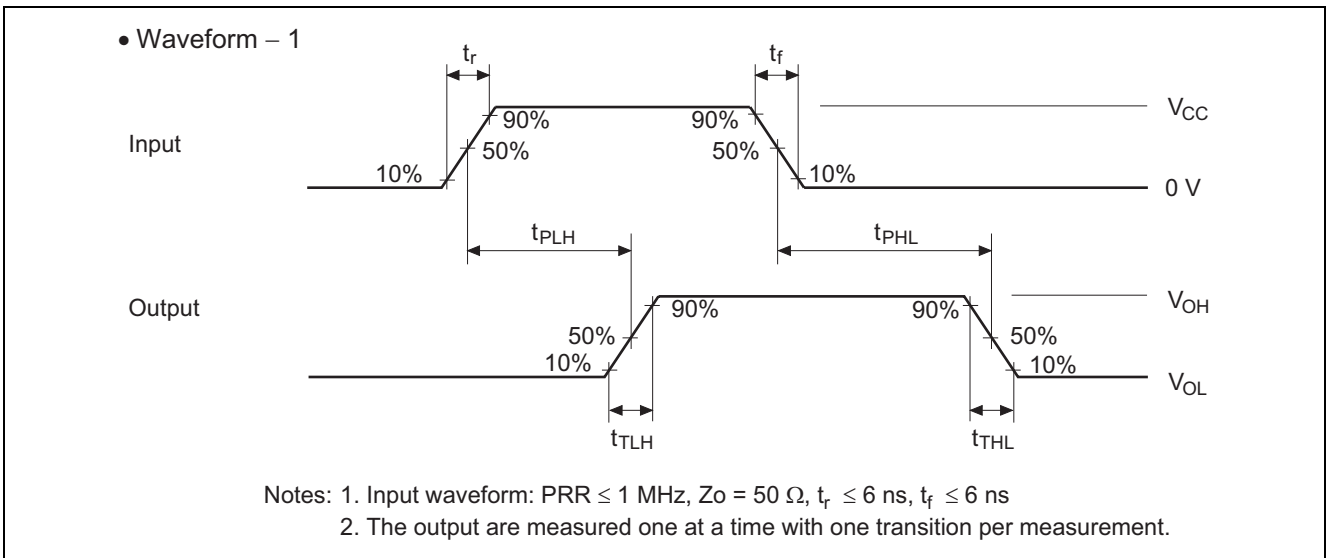

Package Dimensions

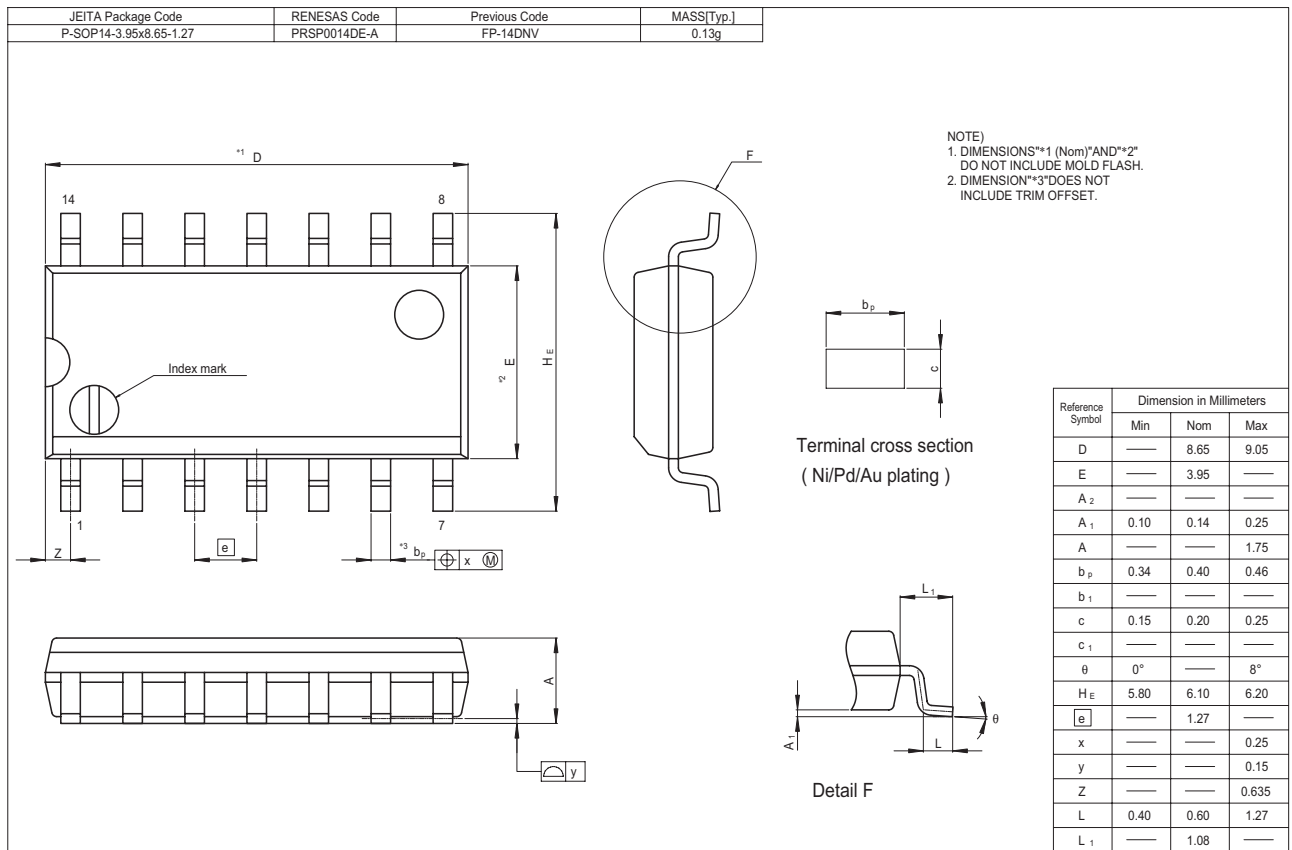
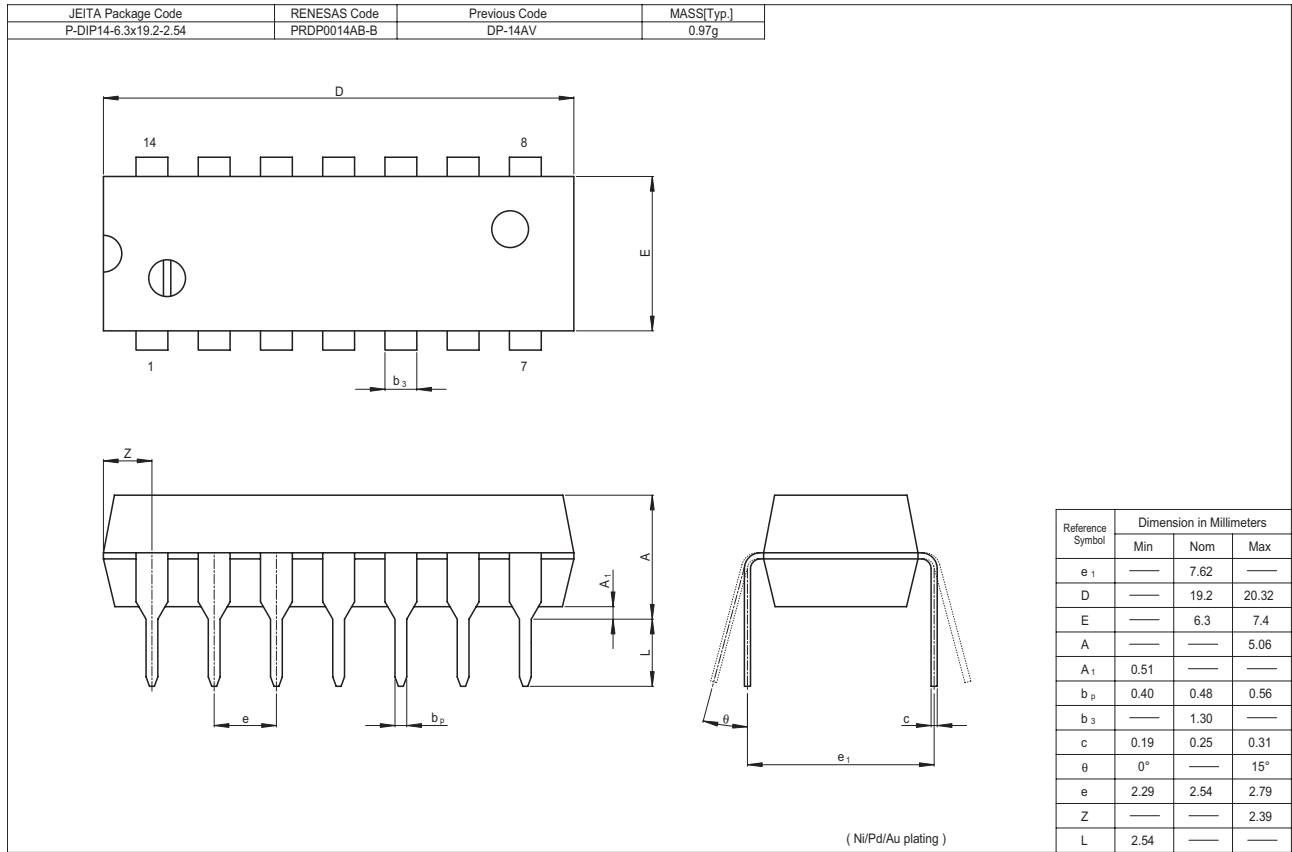

HD74HC32

