





# HD74LS248 • BCD-to-Seven-Segment Decoders/Drivers (internal pull-up outputs)

The HD74LS248 is electrically and functionally identical to the HD74LS48, respectively, and has the same pin assignments as its equivalents. It can be used interchangeably in present or future designs to offer designers a choice between two indicator fonts. The HD74LS48 composes the  and the  without tails and the HD74LS248 composes the  and the  with tails. Composition of all other characters, including display patterns for BCD inputs above nine, is identical. The HD74LS248 features active-low outputs designed for driving indicators directly. All of the circuits have full ripple-blanking input/output controls and a lamp test input. Segment identification and resultant displays are shown below. Display patterns for BCD input counts above 9 are unique symbols to authenticate input conditions. This circuit incorporates automatic leading and/or trailing-edge zero-blanking control (RBI and RBO).

Lamp test (LT) of this type may be performed at any time when the BI/RBO node is at a high level. This type contains an overriding blanking input (BI) which can be used to control the lamp intensity be pulsing or to inhibit the outputs.

## ■ BLOCK DIAGRAM

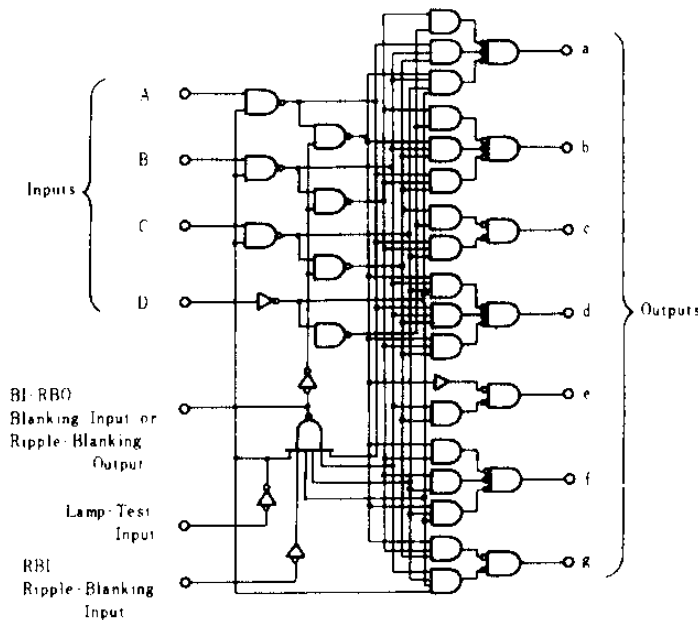

## ■ PIN ARRANGEMENT

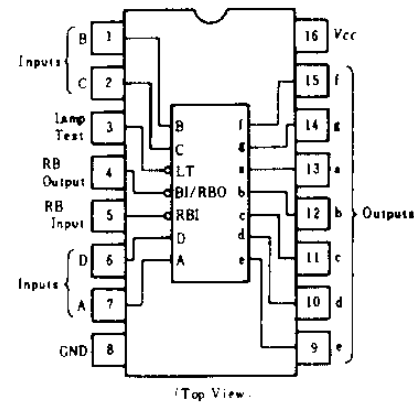

## ■ RECOMMENDED OPERATING CONDITIONS

Item	Symbol	min	typ	max	Unit
Output current	a~g	—	—	~100	μA
	BI/RBO	—	—	~50	
	a~g	—	—	6	mA
	BI/RBO	—	—	3.2	

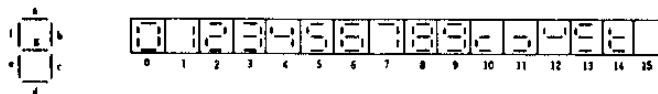

## HD74LS248

## FUNCTION TABLE

Decimal or Function	Inputs						BI/RBO	Outputs							Note
	LT	RBI	D	C	B	A		a	b	c	d	e	f	g	
0	H	H	L	L	L	L	H	H	H	H	H	H	H	L	1
1	H	X	L	L	L	H	H	L	H	H	L	L	L	L	
2	H	X	L	L	H	L	H	H	H	L	H	H	L	H	
3	H	X	L	L	H	H	H	H	H	H	H	L	L	H	
4	H	X	L	H	L	L	H	L	H	H	L	L	H	H	
5	H	X	L	H	L	H	H	H	L	H	H	L	H	H	
6	H	X	L	H	H	L	H	H	L	H	H	H	H	H	
7	H	X	L	H	H	H	H	H	H	H	L	L	L	L	
8	H	X	H	L	L	L	H	H	H	H	H	H	H	H	
9	H	X	H	L	L	H	H	H	H	H	H	L	H	H	
10	H	X	H	L	H	L	H	L	L	L	H	H	L	H	
11	H	X	H	L	H	H	H	L	L	H	H	L	L	H	
12	H	X	H	H	L	L	H	L	H	L	L	L	H	H	
13	H	X	H	H	L	H	H	H	L	L	H	L	H	H	
14	H	X	H	H	H	L	H	L	L	L	H	H	H	H	
15	H	X	H	H	H	H	H	L	L	L	L	L	L	L	
BI	X	X	X	X	X	X	L	L	L	L	L	L	L	L	2
RBI	H	L	L	L	L	L	L	L	L	L	L	L	L	L	3
LT	L	X	X	X	X	X	H	H	H	H	H	H	H	H	4

H; high level, L; low level, X; irrelevant

- Notes:
1. The blanking input (BI) must be open or held at a high-logic level when output functions 0 through 15 are desired.
  2. When a low logic level is applied directly to the blanking input.
  3. When ripple-blanking input (RBI) and inputs A, B, C, and D

are at a low level with the lamp-test input high, all segment outputs go low and the ripple-blanking output (RBO) goes to a low level (response condition).

4. When a blanking input/ripple blanking output (BI/RBO) is open or held high and a low is applied to the lamp-test input, all segment outputs are high.

ELECTRICAL CHARACTERISTICS ( $T_a = -20 \sim +75^\circ\text{C}$ )

Item	Symbol	Test Conditions	min	typ*	max	Unit	
Input voltage	$V_{IH}$		2.0	—	—	V	
	$V_{IL}$		—	—	0.8	V	
Output voltage	$V_{OH}$	$V_{CC}=4.75\text{V}$ , $V_{IH}=2\text{V}$ $V_{IL}=0.8\text{V}$	$I_{OH}=-100\mu\text{A}$ $I_{OH}=-50\mu\text{A}$	2.4	—	V	
	Output current**	$I_O$	$V_{CC}=4.75\text{V}$ , $V_O=0.85\text{V}$	-1.3	—	mA	
Output voltage	$V_{OL}$	$V_{CC}=4.75\text{V}$ , $V_{IH}=2\text{V}$ $V_{IL}=0.8\text{V}$	$I_{OL}=2\text{mA}$ $I_{OL}=6\text{mA}$ $I_{OL}=1.6\text{mA}$ $I_{OL}=3.2\text{mA}$	—	—	V	
	Input current	except BI/RBO	$I_{IH}$	$V_{CC}=5.25\text{V}$ , $V_I=2.7\text{V}$	—	20	$\mu\text{A}$
		except BI/RBO	$I_{IL}$	$V_{CC}=5.25\text{V}$ , $V_I=0.4\text{V}$	—	-0.4	mA
		BI/RBO			—	-1.2	
except BI/RBO	$I_I$	$V_{CC}=5.25\text{V}$ , $V_I=7\text{V}$	—	—	0.1	mA	
Short-circuit output current	$I_{OS}$	$V_{CC}=5.25\text{V}$	-0.3	—	-2	mA	
Supply current***	$I_{CC}$	$V_{CC}=5.25\text{V}$	—	25	38	mA	
Input clamp voltage	$V_{IK}$	$V_{CC}=4.75\text{V}$ , $I_{IN}=-18\text{mA}$	—	—	-1.5	V	

\*  $V_{CC}=5\text{V}$ ,  $T_a=25^\circ\text{C}$ \*\* Input condition as for  $V_{OH}$ \*\*\*  $I_{CC}$  is measured with all outputs open and all inputs at 4.5V.

# HD74LS248

## SWITCHING CHARACTERISTICS ( $V_{CC}=5V$ , $T_a=25^\circ C$ )

Item	Symbol	Input	Test Conditions	min	typ	max	Unit
Propagation delay time	$t_{PLH}$	A	$C_L=15pF$ , $R_L=4k\Omega$	—	—	100	ns
	$t_{PHL}$			—	—	100	
	$t_{PLH}$	RBI	$C_L=15pF$ , $R_L=6k\Omega$	—	—	100	ns
	$t_{PHL}$			—	—	100	

## TESTING METHOD

### 1) Test Circuit

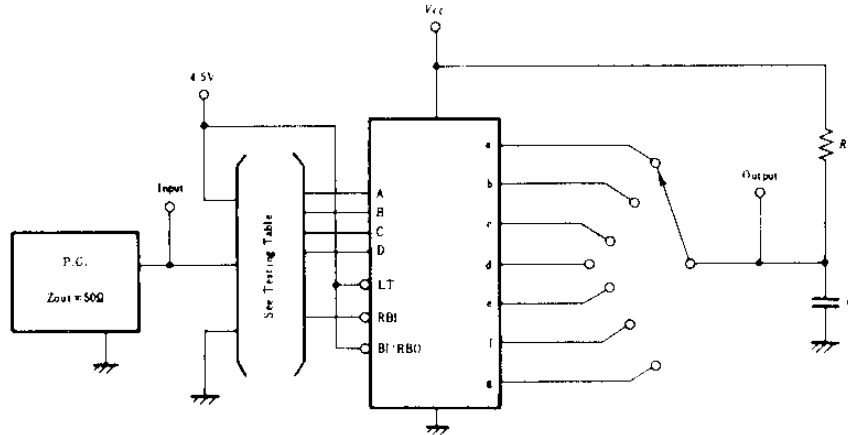

### 2) Testing Table

Item	Inputs					Outputs						
	RBI	D	C	B	A	a	b	c	d	e	f	g
$t_{PLH}$	4.5V	GND	GND	GND	IN	OUT	—	—	OUT	OUT	OUT	—
$t_{PHL}$	4.5V	GND	4.5V	4.5V	IN	—	OUT	—	OUT	OUT	OUT	OUT
	IN	GND	GND	GND	GND	OUT	OUT	OUT	OUT	OUT	OUT	—

### Waveform

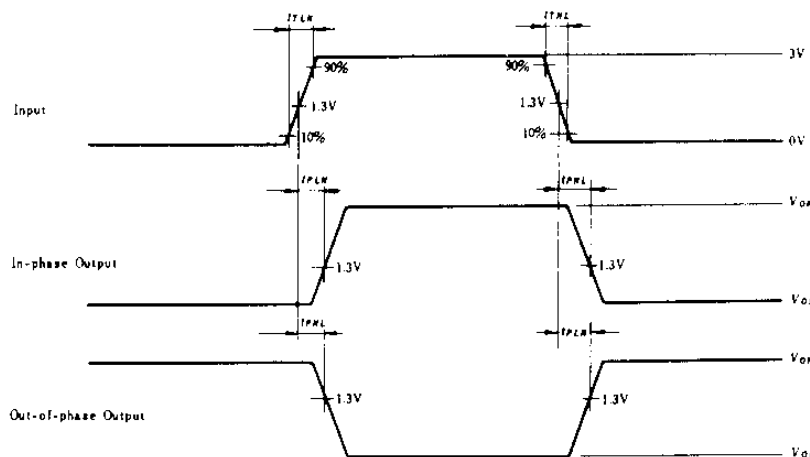

- Notes) 1. Input pulse:  $t_{TLN} \leq 15ns$ ,  $t_{THN} \leq 6ns$ ,  $PRR=1MHz$ , duty cycle=50%  
 2.  $C_L$  includes probe and jig capacitance.

Unit: mm

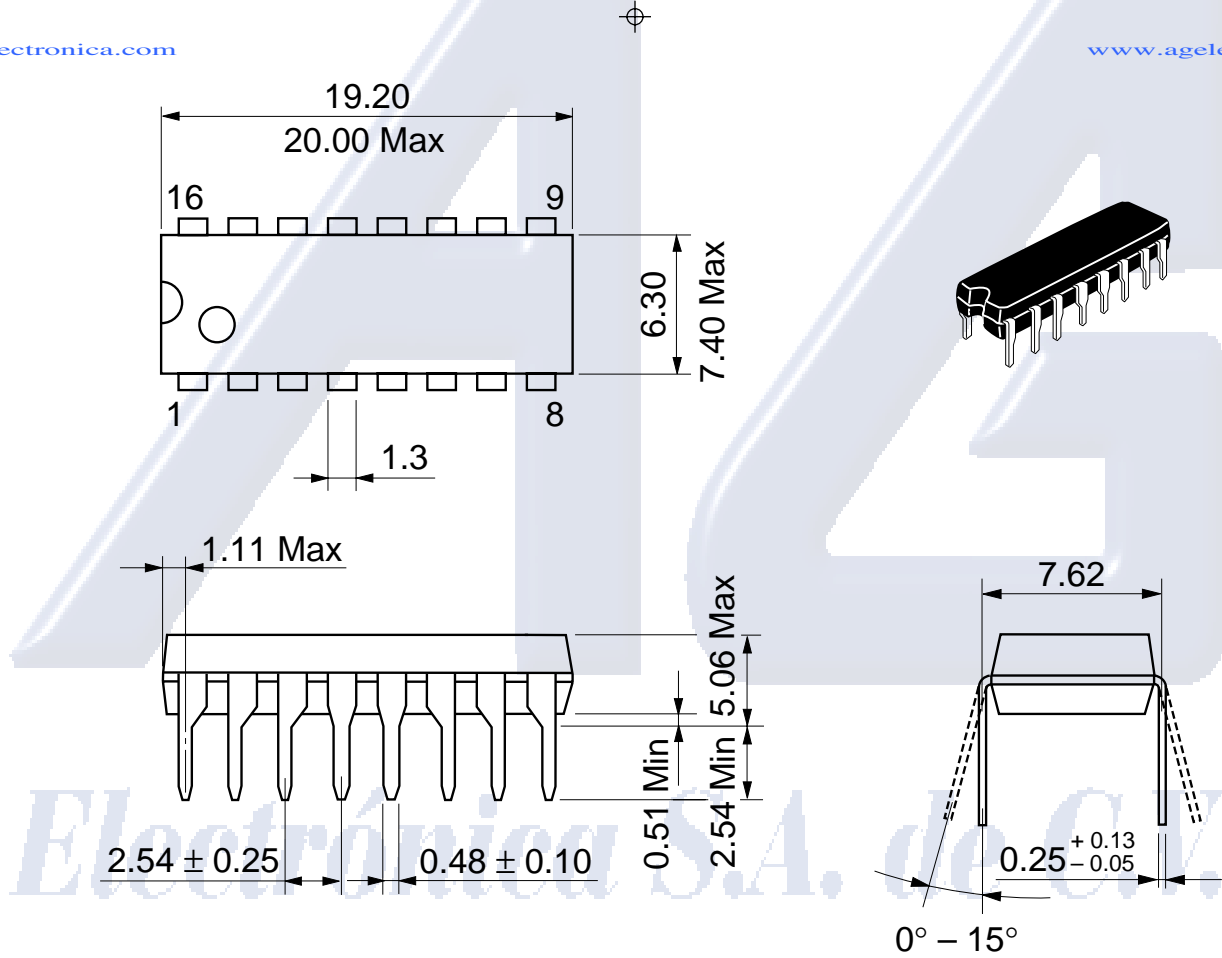

Hitachi Code	DP-16
JEDEC	Conforms
EIAJ	Conforms
Weight (reference value)	1.07 g

Unit: mm

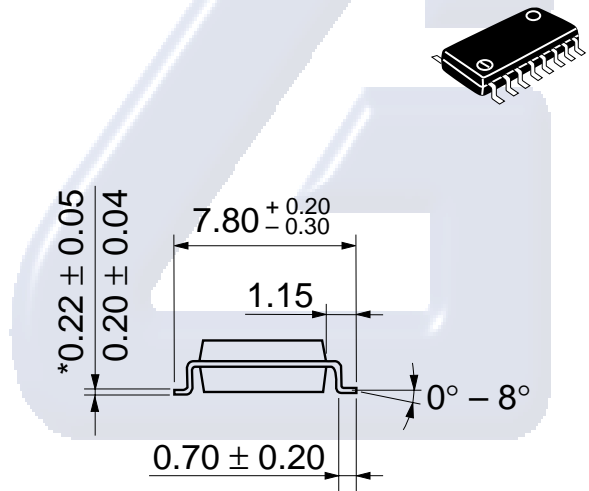
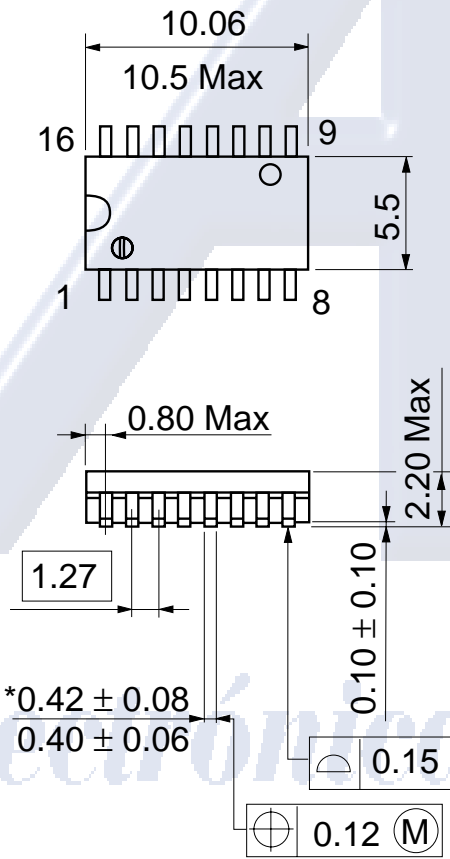

Electrónica S.A. de C.V.

Hitachi Code	FP-16DA
JEDEC	—
EIAJ	Conforms
Weight (reference value)	0.24 g

\*Dimension including the plating thickness  
 Base material dimension

Unit: mm

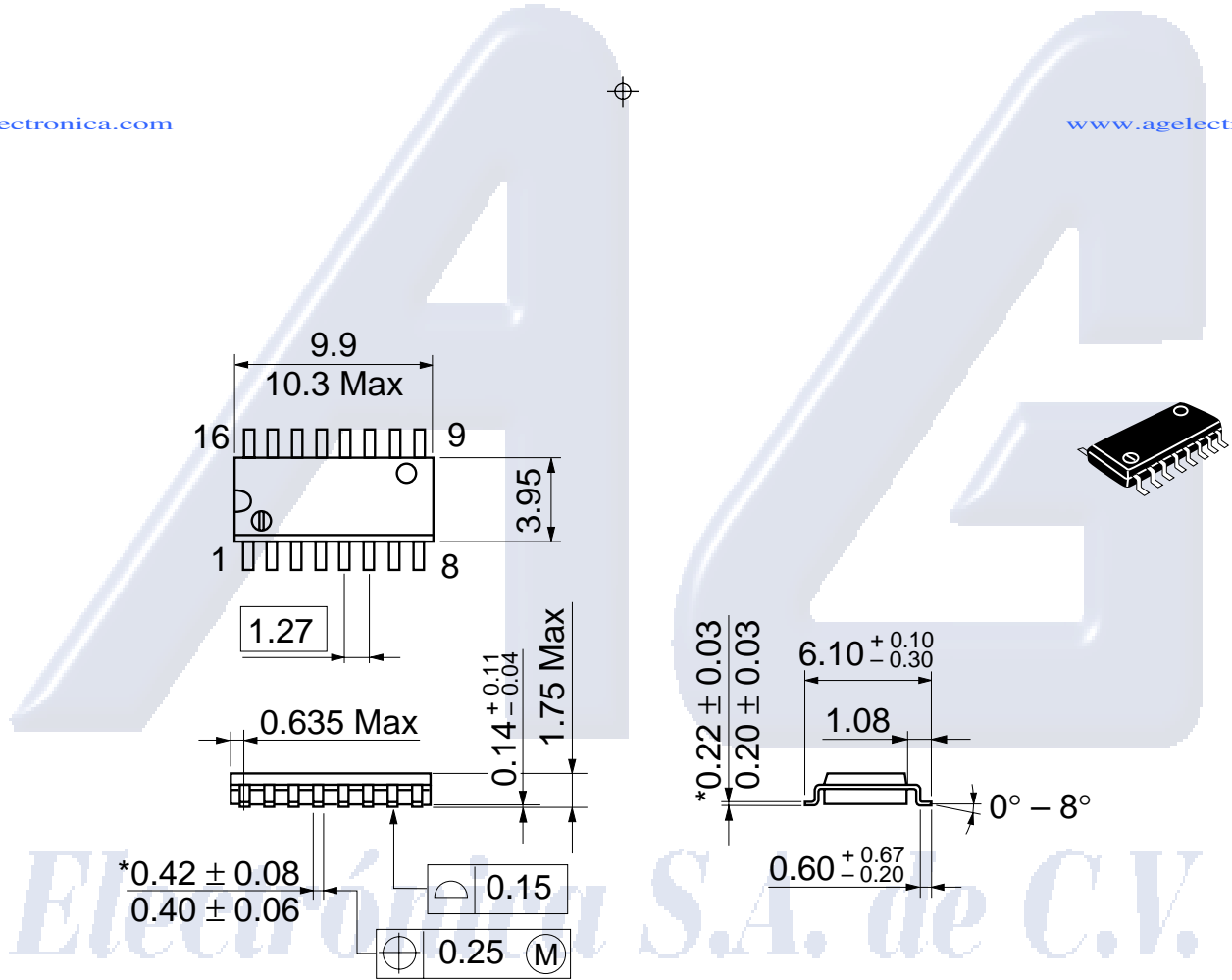

Electrónica S.A. de C.V.

Hitachi Code	FP-16DN
JEDEC	Conforms
EIAJ	Conforms
Weight (reference value)	0.15 g

\*Dimension including the plating thickness  
 \_\_\_\_\_  
 Base material dimension

## Cautions

1. Hitachi neither warrants nor grants licenses of any rights of Hitachi's or any third party's patent, copyright, trademark, or other intellectual property rights for information contained in this document. Hitachi bears no responsibility for problems that may arise with third party's rights, including intellectual property rights, in connection with use of the information contained in this document.
2. Products and product specifications may be subject to change without notice. Confirm that you have received the latest product standards or specifications before final design, purchase or use.
3. Hitachi makes every attempt to ensure that its products are of high quality and reliability. However, contact Hitachi's sales office before using the product in an application that demands especially high quality and reliability or where its failure or malfunction may directly threaten human life or cause risk of bodily injury, such as aerospace, aeronautics, nuclear power, combustion control, transportation, traffic, safety equipment or medical equipment for life support.
4. Design your application so that the product is used within the ranges guaranteed by Hitachi particularly for maximum rating, operating supply voltage range, heat radiation characteristics, installation conditions and other characteristics. Hitachi bears no responsibility for failure or damage when used beyond the guaranteed ranges. Even within the guaranteed ranges, consider normally foreseeable failure rates or failure modes in semiconductor devices and employ systemic measures such as fail-safes, so that the equipment incorporating Hitachi product does not cause bodily injury, fire or other consequential damage due to operation of the Hitachi product.
5. This product is not designed to be radiation resistant.
6. No one is permitted to reproduce or duplicate, in any form, the whole or part of this document without written approval from Hitachi.
7. Contact Hitachi's sales office for any questions regarding this document or Hitachi semiconductor products.

# HITACHI

## Hitachi, Ltd.

Semiconductor & Integrated Circuits.  
Nippon Bldg., 2-6-2, Ohte-machi, Chiyoda-ku, Tokyo 100-0004, Japan  
Tel: Tokyo (03) 3270-2111 Fax: (03) 3270-5109

URL      North America      : <http://semiconductor.hitachi.com/>  
              Europe                : <http://www.hitachi-eu.com/hel/ecg>  
              Asia (Singapore)        : <http://www.has.hitachi.com.sg/grp3/sicd/index.htm>  
              Asia (Taiwan)             : [http://www.hitachi.com.tw/E/Product/SICD\\_Frame.htm](http://www.hitachi.com.tw/E/Product/SICD_Frame.htm)  
              Asia (HongKong)         : <http://www.hitachi.com.hk/eng/bo/grp3/index.htm>  
              Japan                        : <http://www.hitachi.co.jp/Sicd/indx.htm>

### For further information write to:

Hitachi Semiconductor  
(America) Inc.  
179 East Tasman Drive,  
San Jose, CA 95134  
Tel: <1> (408) 433-1990  
Fax: <1> (408) 433-0223

Hitachi Europe GmbH  
Electronic components Group  
Dornacher StraÙe 3  
D-85622 Feldkirchen, Munich  
Germany  
Tel: <49> (89) 9 9180-0  
Fax: <49> (89) 9 29 30 00

Hitachi Europe Ltd.  
Electronic Components Group.  
Whitebrook Park  
Lower Cookham Road  
Maidenhead  
Berkshire SL6 8YA, United Kingdom  
Tel: <44> (1628) 585000  
Fax: <44> (1628) 778322

Hitachi Asia Pte. Ltd.  
16 Collyer Quay #20-00  
Hitachi Tower  
Singapore 049318  
Tel: 535-2100  
Fax: 535-1533

Hitachi Asia Ltd.  
Taipei Branch Office  
3F, Hung Kuo Building, No.167,  
Tun-Hwa North Road, Taipei (105)  
Tel: <886> (2) 2718-3666  
Fax: <886> (2) 2718-8180

Hitachi Asia (Hong Kong) Ltd.  
Group III (Electronic Components)  
7/F., North Tower, World Finance Centre,  
Harbour City, Canton Road, Tsim Sha Tsui,  
Kowloon, Hong Kong  
Tel: <852> (2) 735 9218  
Fax: <852> (2) 730 0281  
Telex: 40815 HITEC HX

Copyright ' Hitachi, Ltd., 1999. All rights reserved. Printed in Japan.

## HITACHI