

10D4812

CONVERTIDOR DC-DC(18V-75V) SALIDA 12V 833mA 10W



Multiple specifications of power module options

MULTIPLE SPECIFICATIONS AVAILABLE

Wide voltage 48V (18-75V) input/regulated single output

MODEL	POWER	VOLTAGE	ELECTRICITY
HLK-10D4805	10W	5V	2000mA
HLK-10D4812	10W	12V	833mA
HLK-10D4815	10W	15V	666mA
HLK-10D4824	10W	24V	416mA

*The same series of products have the same size and pins

*International standard pin size 25.4×25.4×11mm

PRODUCT FEATURES

- Ultra-wide range input (4:1) voltage: 18~75VDC
- Input and output isolation withstand voltage 1500VDC
- Ultra-fast start: 1ms (typical value)
- High efficiency, conversion efficiency up to 91% (Typ)
- Operating temperature range: -40°C~+85°C
- Metal shell, low output ripple
- Good output short circuit and over current protection and self-recovery
- International standard pin, PCB board in-line installation
- Potting and sealing with high-quality environmentally friendly waterproof and thermal conductive glue, dustproof, moistureproof, shockproof and flame retardant
- Meet UL/CE/EMC and safety testing requirements
- Can be used in medical, industrial control, electric power, instrumentation, communication, railway and other fields

Working environment temperature and load characteristics

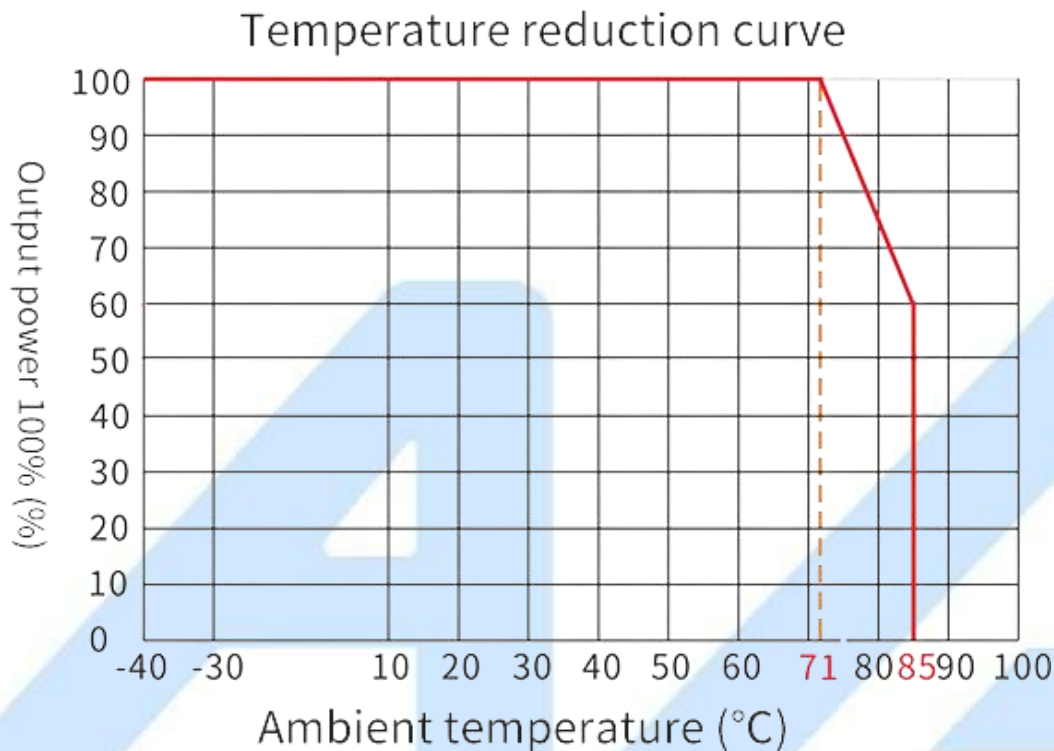

Typical application circuit

Recommended test circuit

Generally recommended capacitance: C1: 47-100 μ F; C2, C3: 10-22 μ F.

All DC/DC converters of this series are tested according to the recommended test circuit shown in the figure below before leaving the factory.

If it is required to further reduce the input and output ripple, the input and output external capacitors C1, C2, C3 can be increased or selected in series with capacitors with a small equivalent impedance, but the capacitance cannot be greater than the maximum capacitive load of the product.

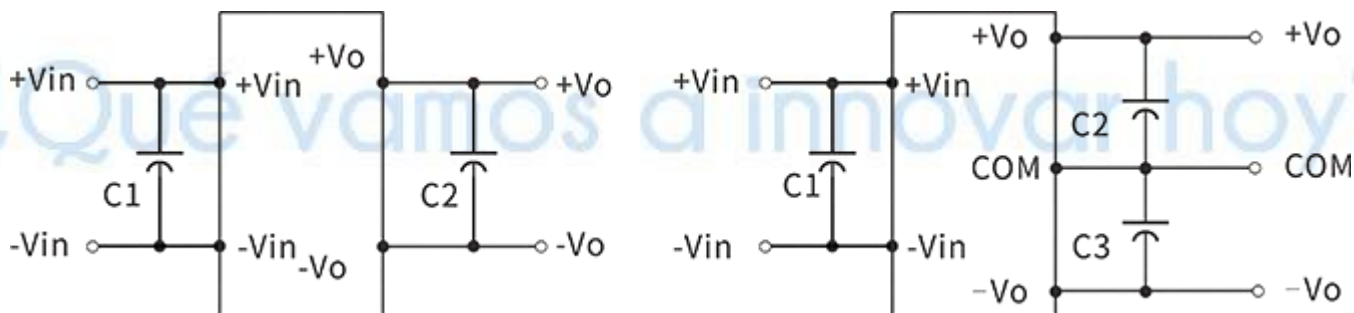

EMC solution-recommended circuit

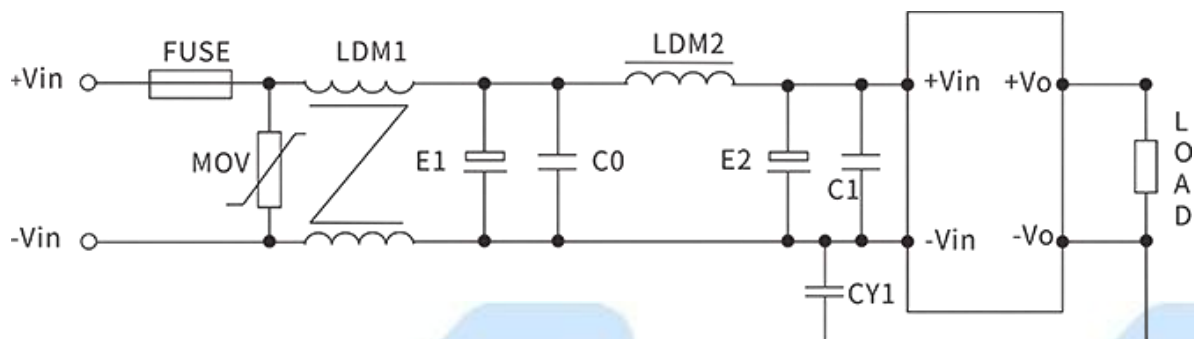

Recommended parameters:

FUSE: Connect the corresponding fuse according to customer needs

MOV varistor: 14D101K

LDM1/common mode inductance: 15mH

E1, E2 electrolytic capacitors: 100 μ F/100V

C0, C1 ceramic capacitors: 1 μ F/100V

LDM2 differential mode inductor: 15 μ H

CY1 safety Y2 capacitor: 1nF/250Vac

Output filter peripheral recommended circuit

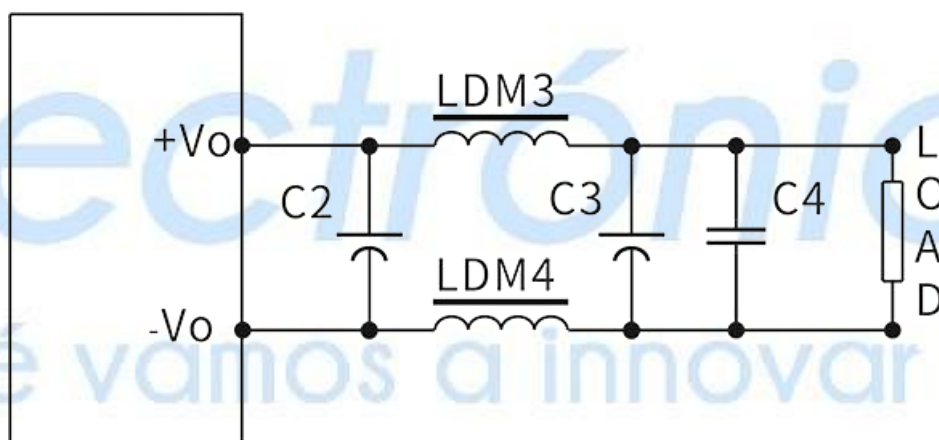

Note:

1. C2 and C3 use high frequency and low resistance electrolytic capacitors, and the total capacity cannot exceed the maximum capacitive load marked in the manual, otherwise the module will not start normally.
2. For capacitive load, a minimum load of 3% must be guaranteed, otherwise it will cause abnormal output of the module.

Recommended parameters:

Device code	5V output	9V/12V/15V output	24V output
LDM3/4 inductance	1 μ H	2.2 μ H	4.7 μ H
C2/3 electrolytic capacitor	220 μ F	100 μ F	68 μ F
C4 ceramic capacitor	1 μ F/50V		

Ripple & noise test: twisted pair method 20MHz bandwidth

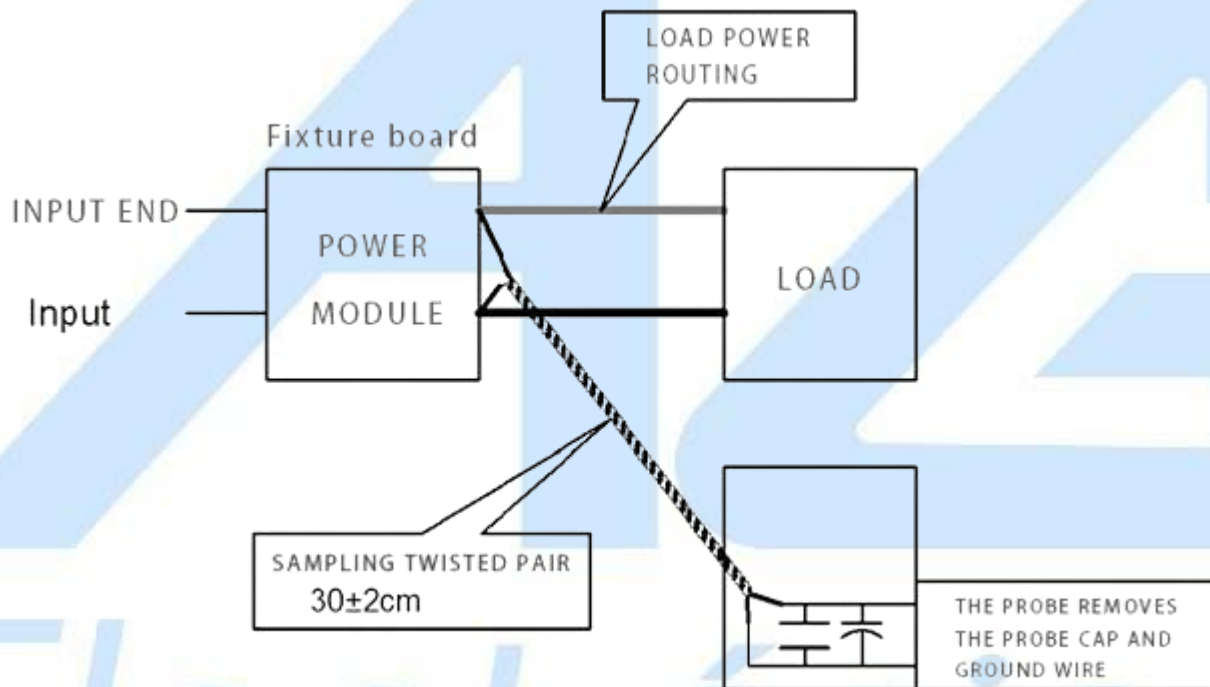

testing method:

1. Ripple noise is connected using 12# twisted pair, the oscilloscope bandwidth is set to 20MHz, 100M bandwidth probe, and 0.1 μ F polypropylene capacitor and 47 μ F high frequency low resistance electrolytic capacitor are connected in parallel to the probe end, and the oscilloscope sampling uses Sample sampling mode .

2. Connect the power input terminal to the input power source, and connect the power output to the electronic load through the fixture board. Use a 30cm \pm 2cm sampling line to sample directly from the power output port for testing. The power line selects the corresponding wire diameter wire with insulation according to the output current. (As shown in FIG)

DIMENSIONS & WEIGHT

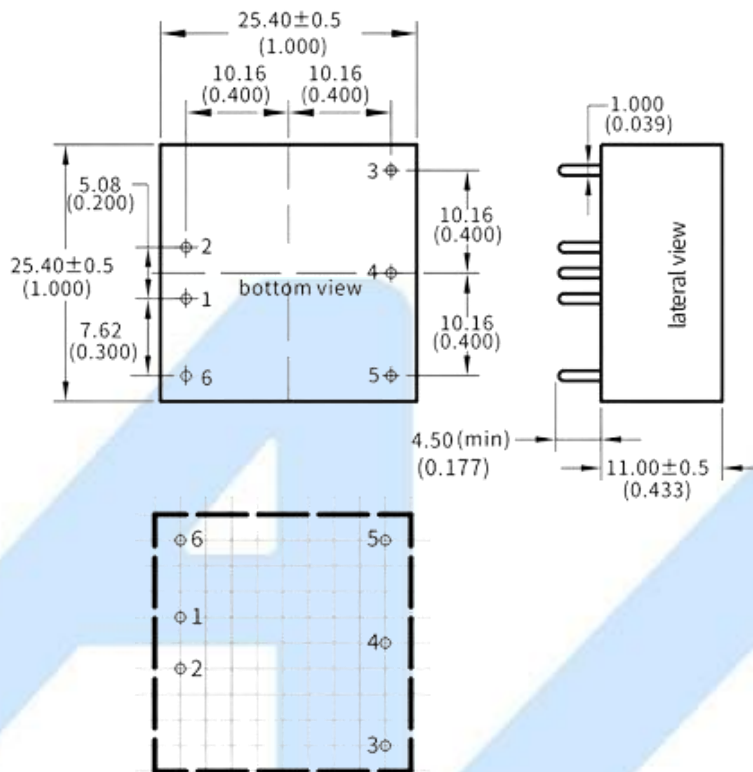

Unit: mm
 Printed board vertical view
 Lattice spacing: 2.54mm
 Unmarked dimensional tolerances ± 0.25 mm
 Stitching diameter tolerance is not indicated ± 0.1 mm

Pin description:

1: -Vin input negative; 2: +Vin input positive; 3: +Vo output positive; 4: NC; 5: -Vo output negative; 6: NC

*Note: If the definition of each pin of the power module is not consistent with the selection manual, the marking on the physical label shall prevail.

 ACOTACIÓN: N/A	AG Electrónica S.A.P.I. de C.V. República del Salvador N° 20 Segundo Piso Teléfono: 55 5130 - 7210		REALIZO: OGJ
	http://www.agelectronica.com	ESCALA: N/A	REV: JFRR
TOLERANCIA: N/A	CONVERTIDOR DC-DC(18V-75V) SALIDA 12V 833mA 10W		
TOLERANCIA: N/A	Fecha: 30/05/2022	No. Parte: 10D4812	