

REVISION RECORD				
REV	ECN	DESCRIPTION	DRFT	DATE
A0		NEW		2022.04.14

NOTES1:
 UL Standard
 1.Rated voltage/current : 300V / 25A
 2.Withstanding voltage : AC2000V/1Min.
 3.Screw torque : M4, 10.53Lb.in
 4.Wire range : 22~12AWG

IEC Standard
 1.

Pollution degree	2
Overtoltage category	II
Rate impulse voltage(KV)	4KV
Rate voltage(V)	750V
Rate current(A)	32A

2.Screw torque : M4, 1.2N·m
 3.Wire range : 0.5~2.5mm²

NOTES2:
 1.Dimension shall be interpreted per ASME Y14.5-2009
 2.Pitch : 9.5mm, Poles : N=02~24P
 3.Operating temperature:-40°C~+105°C
 4.Undimensioned tolerances:

Pitch range in mm		Nominal dimension range in mm						
TO	Over TO	TO	Over TO	TO	Over TO	TO	Over TO	0.1/10
6	10	10	24	30	60	100	150	<
±0.15	±0.20	±0.30	±0.30	±0.50	±0.70	±1.00	±1.30	±2'

5.RoHS Compliance

Ordering Information

JL45CM - 095 XX X XX

Pitch 095=9.5PH No.of pins 02~24 Housing Color Serial code 01~99

B=Black
 G=Green
 U=Blue
 R=Red
 W=White
 Y=Yellow
 O=Orange
 E=Grey

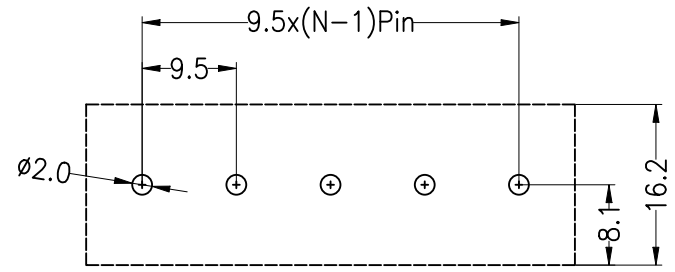
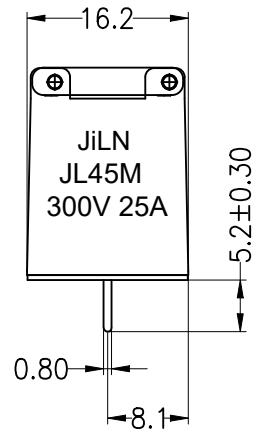
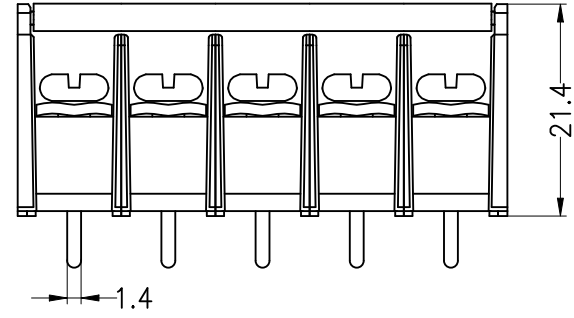
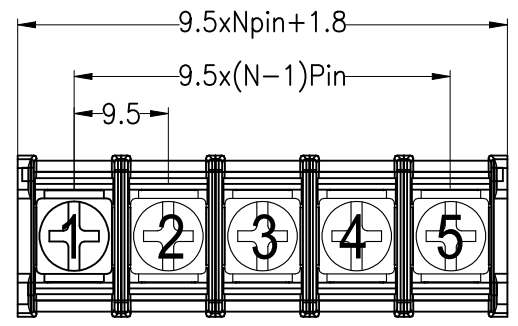

Recommended P.C.B Layout(Top Side)
 (PCB BOARD TOLERANCE±0.05)

DRAW	WH.LU	SCALE	FIT	东莞市锦凌电子有限公司 DONGGUAN JINLING ELECTRONIC CO.,LTD	
		UNIT	mm		
CHECK	W.CHEN	SIZE	A4		
		SHEET	1/1		
APPROVE	J.CHEN	PROJ.		PART NO.	JL45CM-095XXXXX
				TITLE:	JL45CM-XXP栅栏式/带盖