





October 2014

KA78RM33R Low Dropout Voltage Regulator

Features

- 0.5 A / 3.3 V Output Low-Dropout Voltage Regulator
- Low-Dropout Voltage (Max: 0.6 V)
- Over-Current Protection, Thermal Shutdown
- SOA Protection, Short-Circuit Protection

Description

The KA78RM33R is a low-dropout voltage regulator suitable for various electronic equipment. It provides constant voltage power source with surface-mount type package (DPAK). The dropout voltage is below 0.6 V in full-rated current 0.5 A. This regulator has over-current protection, thermal shut-down and the SOA (Safe operating Area) protection.

DPAK

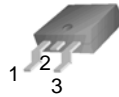

1. V_{IN} 2. GND 3. V_{OUT}

Ordering Information

Part Number	Operating Temperature Range	Top Mark	Package	Packing Method
KA78RM33RTF	-40 to +125°C	KA78RM33	DPAK	Tape and Reel
KA78RM33RTM		KA78RM33	DPAK	Tape and Reel

* Refer to below unit orientation figure for TM / TF suffix packing.

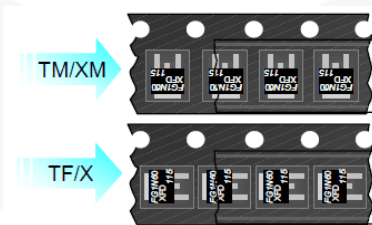

Block Diagram

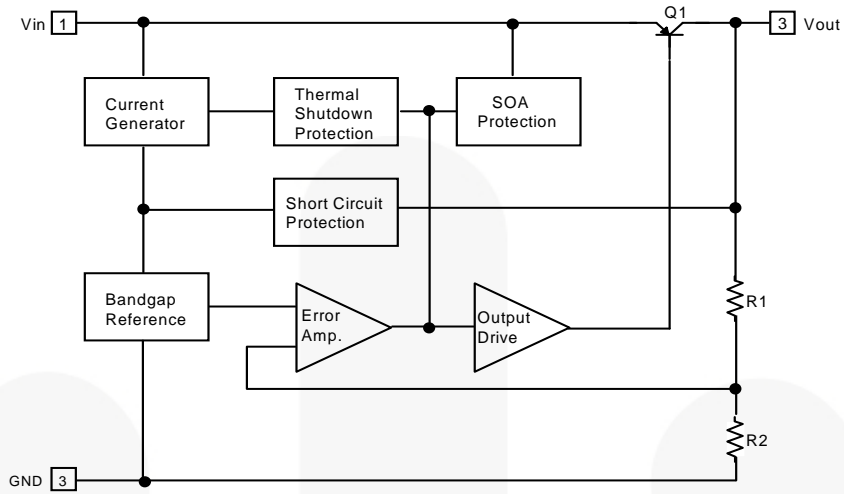

Figure 1. Block Diagram

Typical Application

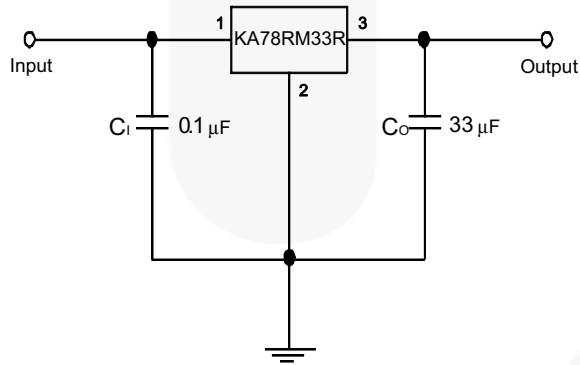

Figure 2. DC Parameters

Notes:

1. C_I is required if the regulator is located an appreciable distance from power supply filter.
2. C_O improves stability and transient response. Refer to the figure 12 for ESR values of capacitors.



Absolute Maximum Ratings

Stresses exceeding the absolute maximum ratings may damage the device. The device may not function or be operable above the recommended operating conditions and stressing the parts to these levels is not recommended. In addition, extended exposure to stresses above the recommended operating conditions may affect device reliability. The absolute maximum ratings are stress ratings only. Values are at $T_A = 25^\circ\text{C}$ unless otherwise noted.

Symbol	Parameter	Value	Remark	Unit
V_{IN}	Input Voltage	20		V
I_O	Output Current	0.5		A
$R_{\theta JA}$	Thermal Resistance Junction-Air	110	No Heatsink	$^\circ\text{C}/\text{W}$
P_D	Power Dissipation	Internally limited		
T_J	Junction Temperature	150		$^\circ\text{C}$
T_{OPR}	Operating Temperature	-40 to +125		$^\circ\text{C}$

Electrical Characteristics

Values are at $T_A = 25^\circ\text{C}$, $V_{IN} = 5\text{ V}$, $I_O = 0.25\text{ A}$ unless otherwise specified.

Symbol	Parameter	Conditions	Min.	Typ.	Max.	Unit
V_{OUT}	Output Voltage	$I_O = 10\text{ mA}$	3.22	3.30	3.38	V
R_{LOAD}	Load Regulation	$5\text{ mA} < I_O < 0.5\text{ A}$		2.0	20	mV
R_{LINE}	Line Regulation	$4.3\text{ V} < V_{IN} < 16\text{ V}$		2.0	20	mV
R_R	Ripple Rejection Ratio	$f = 120\text{ Hz}$, $V_{IN} = 5\text{ V} \pm 0.5\text{ V}_{RMS}$	55			dB
V_{DROP}	Dropout Voltage	$I_O = 0.5\text{ A}$			0.6	V
I_Q	Quiescent Current	$I_O = 0\text{ A}$		5.0	10	mA
I_{PK}	Peak Current	$V_{IN} = 5\text{ V}$	0.5	1.0		A
V_N	Output Noise Voltage	$10\text{ Hz} < f < 100\text{ kHz}$		50		μV_{RMS}
$\Delta V_{OUT}/\Delta T$	Temperature Coefficient of Output Voltage	$-40^\circ\text{C} < T_J < 125^\circ\text{C}$, $I_O = 100\text{ mA}$		-0.2		$\text{mV}/^\circ\text{C}$

Typical Performance Characteristics

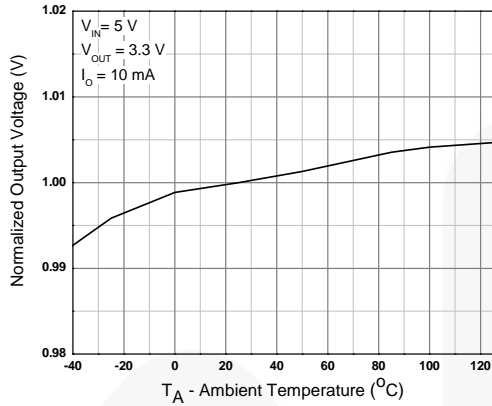

Figure 3. Normalized Output Voltage

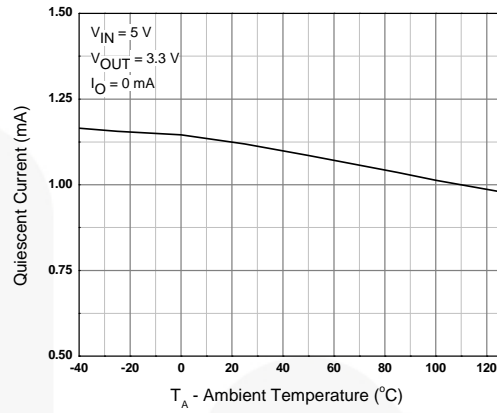

Figure 4. Quiescent vs. Temperature

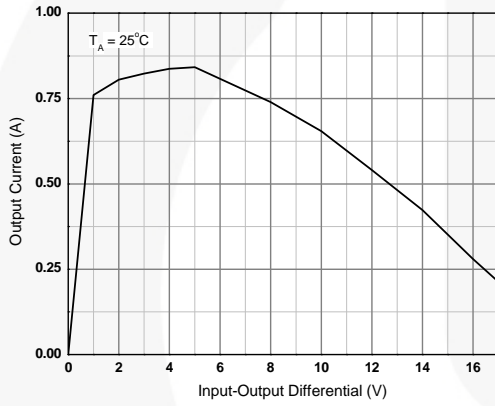

Figure 5. Peak Output Current

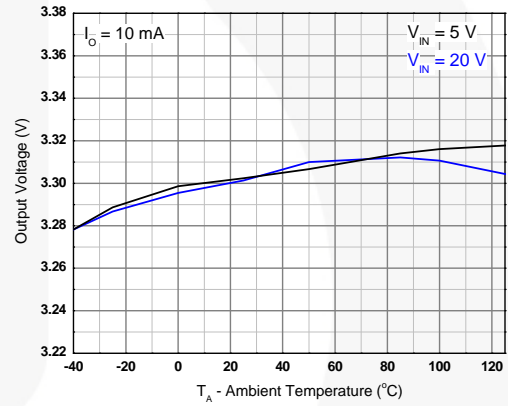

Figure 6. Output Voltage vs. Temperature

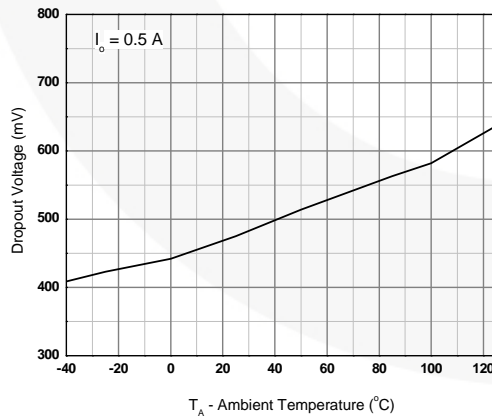

Figure 7. Dropout Voltage vs. Temperature

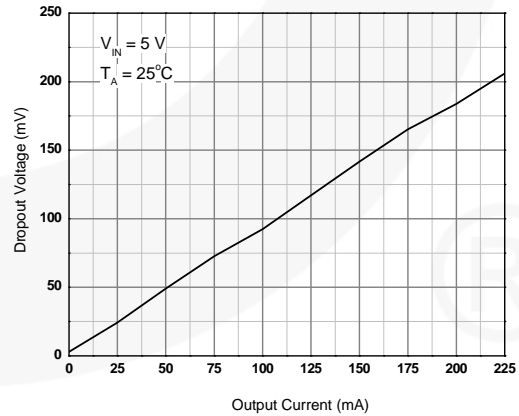

Figure 8. Dropout Voltage vs. Output Current

Typical Performance Characteristics (Continued)

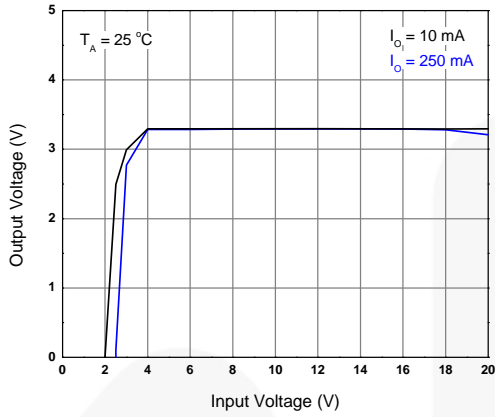

Figure 9. Output Voltage vs. Input Voltage

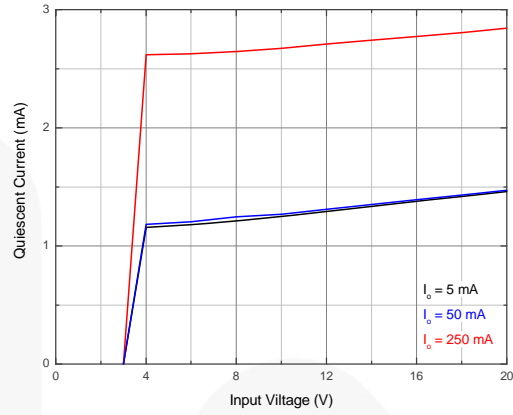

Figure 10. Quiescent Current vs. Input Voltage

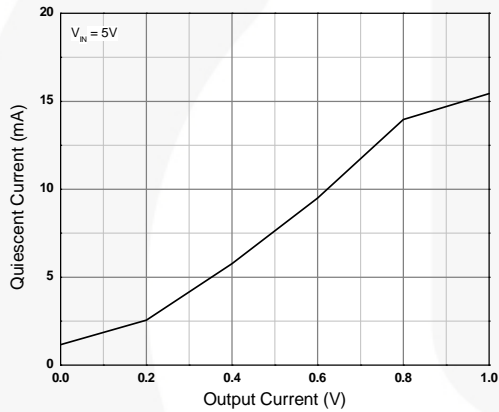

Figure 11. Quiescent Current vs. Output Current

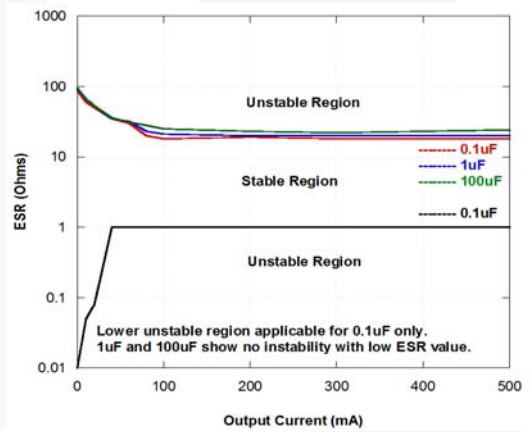
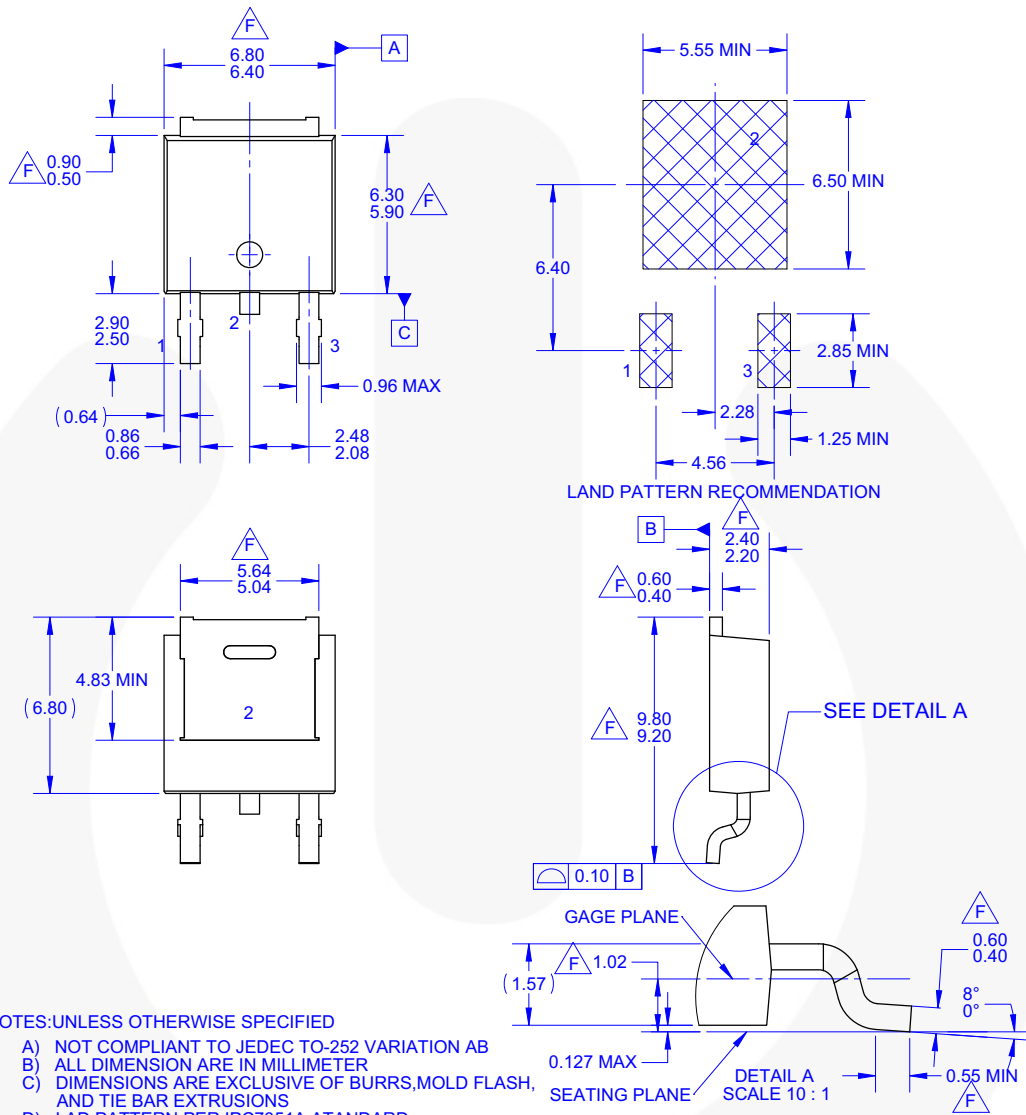

Figure 12. Output Stability vs. Output Capacitor Change

Physical Dimensions



NOTES: UNLESS OTHERWISE SPECIFIED

- A) NOT COMPLIANT TO JEDEC TO-252 VARIATION AB
- B) ALL DIMENSION ARE IN MILLIMETER
- C) DIMENSIONS ARE EXCLUSIVE OF BURRS, MOLD FLASH, AND TIE BAR EXTRUSIONS
- D) LAD PATTERN PER IPC7351A ATANDARD TO228P991X239-3N
- E) DRAWING FILE NAME: MKT-TO252D03REV3.
- F) DOES NOT COMPLY JEDEC STANDARD VALUE.
- G) FAIRCHILD SEMICONDUCTOR.

Figure 13. 3-Lead, TO-252, JEDEC TO-252 VAR. AB, SURFACE MOUNT (DPAK)





TRADEMARKS

The following includes registered and unregistered trademarks and service marks, owned by Fairchild Semiconductor and/or its global subsidiaries, and is not intended to be an exhaustive list of all such trademarks.

AccuPower™
 Awinda®
 AX-CAP®
 BitSiC™
 Build it Now™
 CorePLUS™
 CorePOWER™
 CROSSVOLT™
 CTL™
 Current Transfer Logic™
 DEUXPEED®
 Dual Cool™
 EcoSPARK®
 EfficientMax™
 ESBC™
 F®
 Fairchild®
 Fairchild Semiconductor®
 FACT Quiet Series™
 FACT®
 FAST®
 FastvCore™
 FETBench™
 FPS™

F-PFS™
 FRFET®
 Global Power Resource SM
 GreenBridge™
 Green FPS™
 Green FPS™ e-Series™
 Gmax™
 GTO™
 IntelliMAX™
 ISOPLANAR™
 Making Small Speakers Sound Louder and Better™
 MegaBuck™
 MICROCOPPLER™
 MicroFET™
 MicroPak™
 MicroPak2™
 MillerDrive™
 MotionMax™
 MotionGrid®
 MTI®
 MTx®
 MVN®
 mWSaver®
 OptoHiT™

®
 PowerTrench®
 PowerXS™
 Programmable Active Droop™
 QFET®
 QS™
 Quiet Series™
 RapidConfigure™
™
 Saving our world, 1mW/W/kW at a time™
 SignalWise™
 SmartMax™
 SMART START™
 Solutions for Your Success™
 SPM®
 STEALTH™
 SuperFET®
 SuperSOT™-3
 SuperSOT™-6
 SuperSOT™-8
 SupreMOS®
 SyncFET™
 Sync-Lock™

 SYSTEM GENERAL®
 TinyBoost®
 TinyBuck®
 TinyCalc™
 TinyLogic®
 TINYOPTO™
 TinyPower™
 TinyPWM™
 TinyWire™
 TranSiC™
 TriFault Detect™
 TRUECURRENT®*
 μSerDes™

 UHC®
 Ultra FRFET™
 UniFET™
 VCX™
 VisualMax™
 VoltagePlus™
 XS™
 Xsens™
 仙童™

* Trademarks of System General Corporation, used under license by Fairchild Semiconductor.



