



L7800 SERIES

POSITIVE VOLTAGE REGULATORS

- OUTPUT CURRENT UP TO 1.5 A
- OUTPUT VOLTAGES OF 5; 5.2; 6; 8; 8.5; 9; 12; 15; 18; 24V
- THERMAL OVERLOAD PROTECTION
- SHORT CIRCUIT PROTECTION
- OUTPUT TRANSITION SOA PROTECTION

DESCRIPTION

The L7800 series of three-terminal positive regulators is available in TO-220 TO-220FP TO-3 and D²PAK packages and several fixed output voltages, making it useful in a wide range of applications. These regulators can provide local on-card regulation, eliminating the distribution problems associated with single point regulation. Each type employs internal current limiting, thermal shut-down and safe area protection, making it essentially indestructible. If adequate heat sinking is provided, they can deliver over 1A output current. Although designed primarily as fixed voltage regulators, these devices can be used with external components to obtain adjustable voltages and currents.

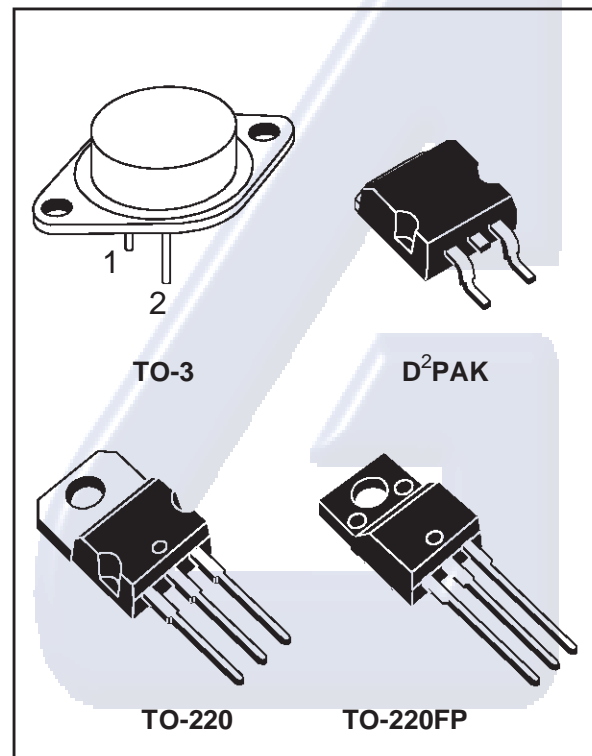

BLOCK DIAGRAM

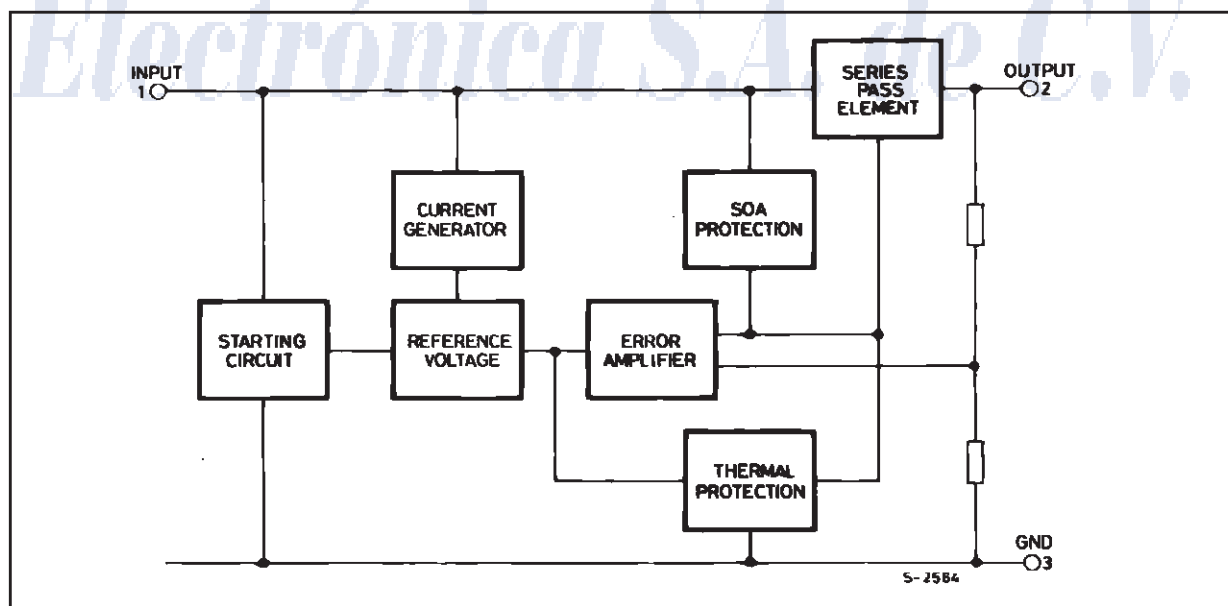

L7800**ABSOLUTE MAXIMUM RATINGS**

Symbol	Parameter	Value	Unit
V_i	DC Input Voltage (for $V_O = 5$ to 18V) (for $V_O = 20, 24V$)	35	V
		40	V
I_o	Output Current	Internally limited	
P_{tot}	Power Dissipation	Internally limited	
T_{op}	Operating Junction Temperature Range (for L7800) (for L7800C)	-55 to 150	°C
		0 to 150	°C
T_{stg}	Storage Temperature Range	-65 to 150	°C

THERMAL DATA

Symbol	Parameter	D ² PAK	TO-220	TO-220FP	TO-3	Unit
$R_{thj-case}$	Thermal Resistance Junction-case Max	3	3	5	4	°C/W
$R_{thj-amb}$	Thermal Resistance Junction-ambient Max	62.5	50	60	35	°C/W

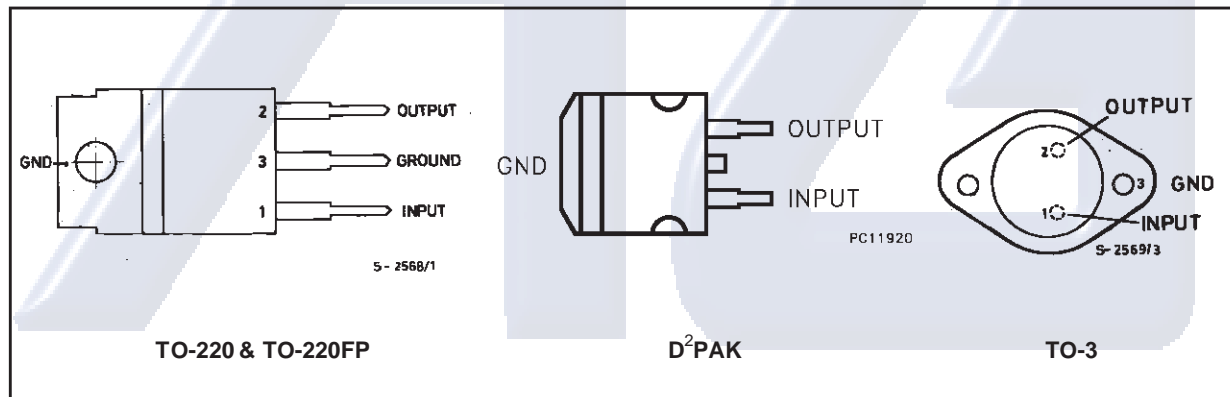
CONNECTION DIAGRAM AND ORDERING NUMBERS (top view)

Type	TO-220	D ² PAK (*)	TO-220FP	TO-3	Output Voltage
L7805				L7805T	5V
L7805C	L7805CV	L7805CD2T	L7805CP	L7805CT	5V
L7852C	L7852CV	L7852CD2T	L7852CP	L7852CT	5.2V
L7806				L7806T	6V
L7806C	L7806CV	L7806CD2T	L7806CP	L7806CT	6V
L7808				L7808T	8V
L7808C	L7808CV	L7808CD2T	L7808CP	L7808CT	8V
L7885C	L7885CV	L7885CD2T	L7885CP	L7885CT	8.5V
L7809C	L7809CV	L7809CD2T	L7809CP	L7809CT	9V
L7812				L7812T	12V
L7812C	L7812CV	L7812CD2T	L7812CP	L7812CT	12V
L7815				L7815T	15V
L7815C	L7815CV	L7815CD2T	L7815CP	L7815CT	15V
L7818				L7818T	18V
L7818C	L7818CV	L7818CD2T	L7818CP	L7818CT	18V
L7820				L7820T	20V
L7820C	L7820CV	L7820CD2T	L7820CP	L7820CT	20V
L7824				L7824T	24V
L7824C	L7824CV	L7824CD2T	L7824CP	L7824CT	24V

(*) AVAILABLE IN TAPE AND REEL WITH "-TR" SUFFIX

APPLICATION CIRCUIT

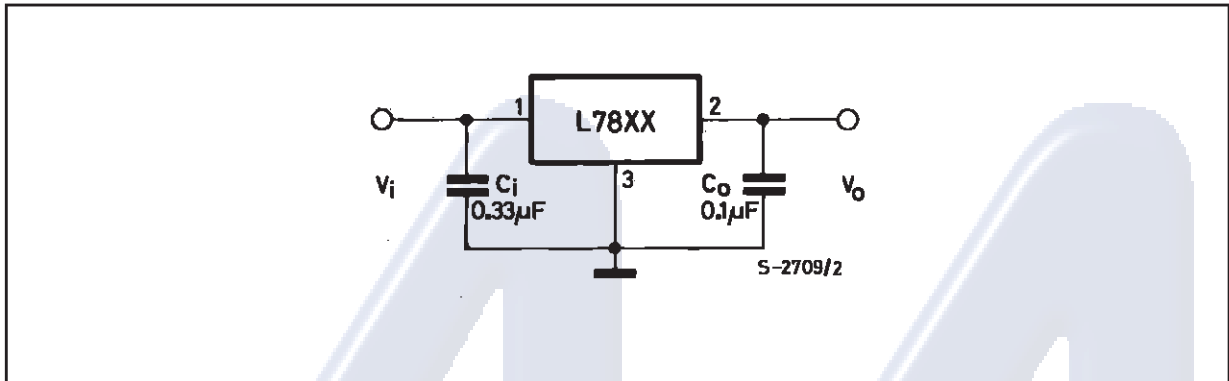

SCHEMATIC DIAGRAM

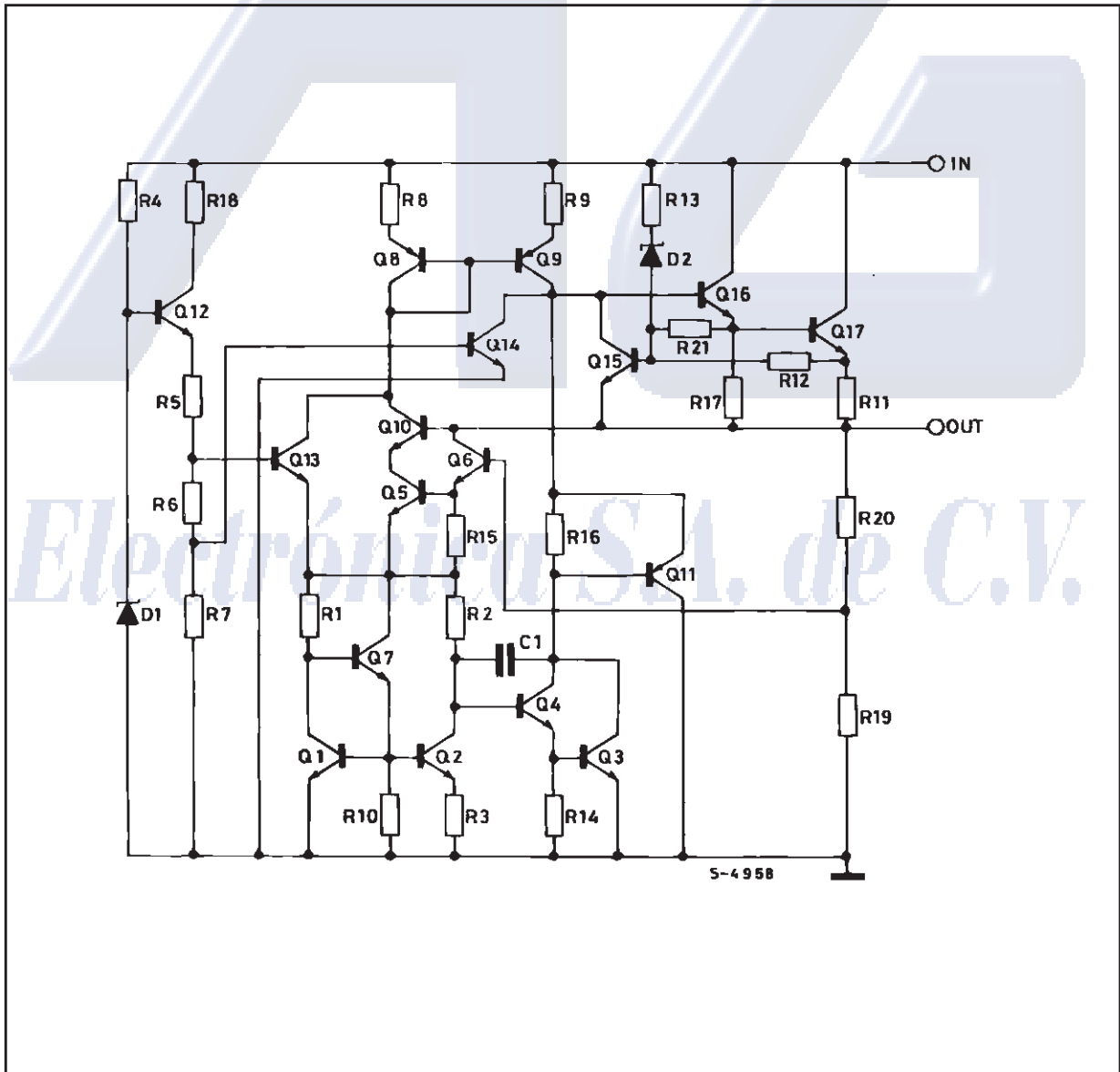

L7800

TEST CIRCUITS

Figure 1 : DC Parameter

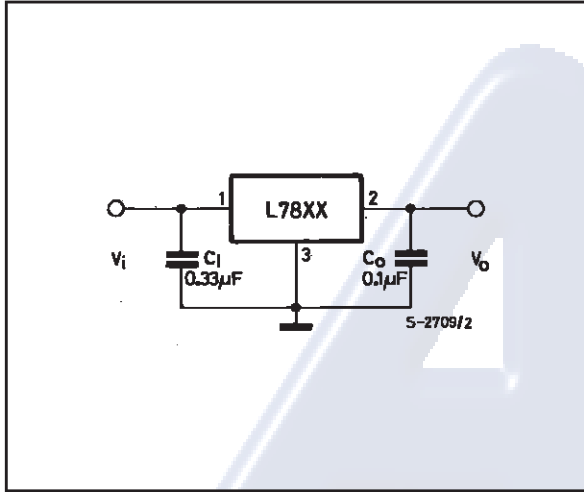

Figure 2 : Load Regulation.

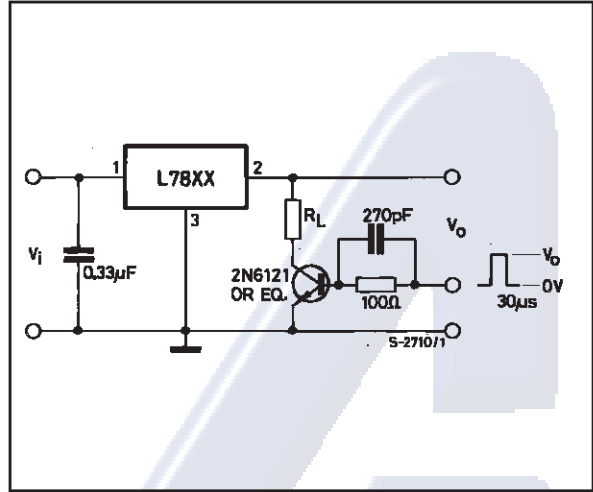
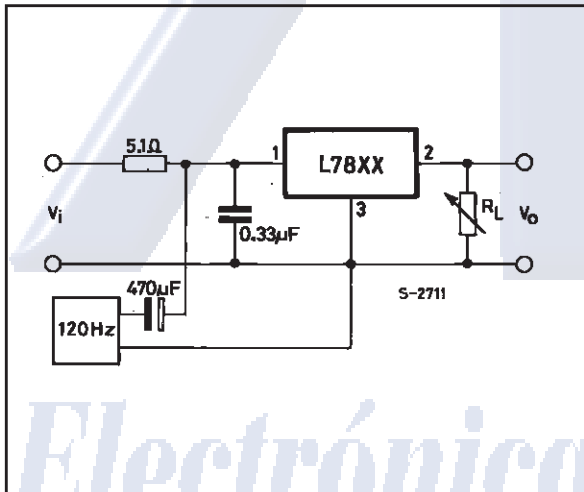

Figure 3 : Ripple Rejection.



Electrónica S.A. de C.V.

L7800

ELECTRICAL CHARACTERISTICS FOR L7805 (refer to the test circuits, $T_j = -55$ to 150 °C, $V_i = 10$ V, $I_o = 500$ mA, $C_i = 0.33$ μ F, $C_o = 0.1$ μ F unless otherwise specified)

Symbol	Parameter	Test Conditions	Min.	Typ.	Max.	Unit
V_o	Output Voltage	$T_j = 25$ °C	4.8	5	5.2	V
V_o	Output Voltage	$I_o = 5$ mA to 1 A $P_o \leq 15$ W $V_i = 8$ to 20 V	4.65	5	5.35	V
ΔV_o^*	Line Regulation	$V_i = 7$ to 25 V $T_j = 25$ °C $V_i = 8$ to 12 V $T_j = 25$ °C		3 1	50 25	mV mV
ΔV_o^*	Load Regulation	$I_o = 5$ to 1500 mA $T_j = 25$ °C $I_o = 250$ to 750 mA $T_j = 25$ °C			100 25	mV mV
I_d	Quiescent Current	$T_j = 25$ °C			6	mA
ΔI_d	Quiescent Current Change	$I_o = 5$ to 1000 mA			0.5	mA
ΔI_d	Quiescent Current Change	$V_i = 8$ to 25 V			0.8	mA
$\frac{\Delta V_o}{\Delta T}$	Output Voltage Drift	$I_o = 5$ mA		0.6		mV/°C
eN	Output Noise Voltage	B = 10Hz to 100KHz $T_j = 25$ °C			40	μ V/ V_o
SVR	Supply Voltage Rejection	$V_i = 8$ to 18 V $f = 120$ Hz	68			dB
V_d	Dropout Voltage	$I_o = 1$ A $T_j = 25$ °C		2	2.5	V
R_o	Output Resistance	$f = 1$ KHz		17		m Ω
I_{sc}	Short Circuit Current	$V_i = 35$ V $T_j = 25$ °C		0.75	1.2	A
I_{scp}	Short Circuit Peak Current	$T_j = 25$ °C	1.3	2.2	3.3	A

ELECTRICAL CHARACTERISTICS FOR L7806 (refer to the test circuits, $T_j = -55$ to 150 °C, $V_i = 15$ V, $I_o = 500$ mA, $C_i = 0.33$ μ F, $C_o = 0.1$ μ F unless otherwise specified)

Symbol	Parameter	Test Conditions	Min.	Typ.	Max.	Unit
V_o	Output Voltage	$T_j = 25$ °C	5.75	6	6.25	V
V_o	Output Voltage	$I_o = 5$ mA to 1 A $P_o \leq 15$ W $V_i = 9$ to 21 V	5.65	6	6.35	V
ΔV_o^*	Line Regulation	$V_i = 8$ to 25 V $T_j = 25$ °C $V_i = 9$ to 13 V $T_j = 25$ °C			60 30	mV mV
ΔV_o^*	Load Regulation	$I_o = 5$ to 1500 mA $T_j = 25$ °C $I_o = 250$ to 750 mA $T_j = 25$ °C			100 30	mV mV
I_d	Quiescent Current	$T_j = 25$ °C			6	mA
ΔI_d	Quiescent Current Change	$I_o = 5$ to 1000 mA			0.5	mA
ΔI_d	Quiescent Current Change	$V_i = 9$ to 25 V			0.8	mA
$\frac{\Delta V_o}{\Delta T}$	Output Voltage Drift	$I_o = 5$ mA		0.7		mV/°C
eN	Output Noise Voltage	B = 10Hz to 100KHz $T_j = 25$ °C			40	μ V/ V_o
SVR	Supply Voltage Rejection	$V_i = 9$ to 19 V $f = 120$ Hz	65			dB
V_d	Dropout Voltage	$I_o = 1$ A $T_j = 25$ °C		2	2.5	V
R_o	Output Resistance	$f = 1$ KHz		19		m Ω
I_{sc}	Short Circuit Current	$V_i = 35$ V $T_j = 25$ °C		0.75	1.2	A
I_{scp}	Short Circuit Peak Current	$T_j = 25$ °C	1.3	2.2	3.3	A

* Load and line regulation are specified at constant junction temperature. Changes in V_o due to heating effects must be taken into account separately. Pulse testing with low duty cycle is used.

L7800

ELECTRICAL CHARACTERISTICS FOR L7808 (refer to the test circuits, $T_j = -55$ to 150 °C, $V_i = 14$ V, $I_o = 500$ mA, $C_i = 0.33$ μ F, $C_o = 0.1$ μ F unless otherwise specified)

Symbol	Parameter	Test Conditions	Min.	Typ.	Max.	Unit
V_o	Output Voltage	$T_j = 25$ °C	7.7	8	8.3	V
V_o	Output Voltage	$I_o = 5$ mA to 1 A $P_o \leq 15$ W $V_i = 11.5$ to 23 V	7.6	8	8.4	V
ΔV_o^*	Line Regulation	$V_i = 10.5$ to 25 V $T_j = 25$ °C $V_i = 11$ to 17 V $T_j = 25$ °C			80 40	mV mV
ΔV_o^*	Load Regulation	$I_o = 5$ to 1500 mA $T_j = 25$ °C $I_o = 250$ to 750 mA $T_j = 25$ °C			100 40	mV mV
I_d	Quiescent Current	$T_j = 25$ °C			6	mA
ΔI_d	Quiescent Current Change	$I_o = 5$ to 1000 mA			0.5	mA
ΔI_d	Quiescent Current Change	$V_i = 11.5$ to 25 V			0.8	mA
$\frac{\Delta V_o}{\Delta T}$	Output Voltage Drift	$I_o = 5$ mA		1		mV/°C
eN	Output Noise Voltage	B = 10Hz to 100KHz $T_j = 25$ °C			40	μ V/ V_o
SVR	Supply Voltage Rejection	$V_i = 11.5$ to 21.5 V $f = 120$ Hz	62			dB
V_d	Dropout Voltage	$I_o = 1$ A $T_j = 25$ °C		2	2.5	V
R_o	Output Resistance	$f = 1$ KHz		16		m Ω
I_{sc}	Short Circuit Current	$V_i = 35$ V $T_j = 25$ °C		0.75	1.2	A
I_{scp}	Short Circuit Peak Current	$T_j = 25$ °C	1.3	2.2	3.3	A

ELECTRICAL CHARACTERISTICS FOR L7812 (refer to the test circuits, $T_j = -55$ to 150 °C, $V_i = 19$ V, $I_o = 500$ mA, $C_i = 0.33$ μ F, $C_o = 0.1$ μ F unless otherwise specified)

Symbol	Parameter	Test Conditions	Min.	Typ.	Max.	Unit
V_o	Output Voltage	$T_j = 25$ °C	11.5	12	12.5	V
V_o	Output Voltage	$I_o = 5$ mA to 1 A $P_o \leq 15$ W $V_i = 15.5$ to 27 V	11.4	12	12.6	V
ΔV_o^*	Line Regulation	$V_i = 14.5$ to 30 V $T_j = 25$ °C $V_i = 16$ to 22 V $T_j = 25$ °C			120 60	mV mV
ΔV_o^*	Load Regulation	$I_o = 5$ to 1500 mA $T_j = 25$ °C $I_o = 250$ to 750 mA $T_j = 25$ °C			100 60	mV mV
I_d	Quiescent Current	$T_j = 25$ °C			6	mA
ΔI_d	Quiescent Current Change	$I_o = 5$ to 1000 mA			0.5	mA
ΔI_d	Quiescent Current Change	$V_i = 15$ to 30 V			0.8	mA
$\frac{\Delta V_o}{\Delta T}$	Output Voltage Drift	$I_o = 5$ mA		1.5		mV/°C
eN	Output Noise Voltage	B = 10Hz to 100KHz $T_j = 25$ °C			40	μ V/ V_o
SVR	Supply Voltage Rejection	$V_i = 15$ to 25 V $f = 120$ Hz	61			dB
V_d	Dropout Voltage	$I_o = 1$ A $T_j = 25$ °C		2	2.5	V
R_o	Output Resistance	$f = 1$ KHz		18		m Ω
I_{sc}	Short Circuit Current	$V_i = 35$ V $T_j = 25$ °C		0.75	1.2	A
I_{scp}	Short Circuit Peak Current	$T_j = 25$ °C	1.3	2.2	3.3	A

* Load and line regulation are specified at constant junction temperature. Changes in V_o due to heating effects must be taken into account separately. Pulse testing with low duty cycle is used.

L7800

ELECTRICAL CHARACTERISTICS FOR L7815 (refer to the test circuits, $T_j = -55$ to 150 °C, $V_i = 23$ V, $I_o = 500$ mA, $C_i = 0.33$ μ F, $C_o = 0.1$ μ F unless otherwise specified)

Symbol	Parameter	Test Conditions	Min.	Typ.	Max.	Unit
V_o	Output Voltage	$T_j = 25$ °C	14.4	15	15.6	V
V_o	Output Voltage	$I_o = 5$ mA to 1 A $P_o \leq 15$ W $V_i = 18.5$ to 30 V	14.25	15	15.75	V
ΔV_o^*	Line Regulation	$V_i = 17.5$ to 30 V $T_j = 25$ °C $V_i = 20$ to 26 V $T_j = 25$ °C			150 75	mV mV
ΔV_o^*	Load Regulation	$I_o = 5$ to 1500 mA $T_j = 25$ °C $I_o = 250$ to 750 mA $T_j = 25$ °C			150 75	mV mV
I_d	Quiescent Current	$T_j = 25$ °C			6	mA
ΔI_d	Quiescent Current Change	$I_o = 5$ to 1000 mA			0.5	mA
ΔI_d	Quiescent Current Change	$V_i = 18.5$ to 30 V			0.8	mA
$\frac{\Delta V_o}{\Delta T}$	Output Voltage Drift	$I_o = 5$ mA		1.8		mV/°C
eN	Output Noise Voltage	B = 10Hz to 100KHz $T_j = 25$ °C			40	μ V/ V_o
SVR	Supply Voltage Rejection	$V_i = 18.5$ to 28.5 V $f = 120$ Hz	60			dB
V_d	Dropout Voltage	$I_o = 1$ A $T_j = 25$ °C		2	2.5	V
R_o	Output Resistance	$f = 1$ KHz		19		m Ω
I_{sc}	Short Circuit Current	$V_i = 35$ V $T_j = 25$ °C		0.75	1.2	A
I_{scp}	Short Circuit Peak Current	$T_j = 25$ °C	1.3	2.2	3.3	A

ELECTRICAL CHARACTERISTICS FOR L7818 (refer to the test circuits, $T_j = -55$ to 150 °C, $V_i = 26$ V, $I_o = 500$ mA, $C_i = 0.33$ μ F, $C_o = 0.1$ μ F unless otherwise specified)

Symbol	Parameter	Test Conditions	Min.	Typ.	Max.	Unit
V_o	Output Voltage	$T_j = 25$ °C	17.3	18	18.7	V
V_o	Output Voltage	$I_o = 5$ mA to 1 A $P_o \leq 15$ W $V_i = 22$ to 33 V	17.1	18	18.9	V
ΔV_o^*	Line Regulation	$V_i = 21$ to 33 V $T_j = 25$ °C $V_i = 24$ to 30 V $T_j = 25$ °C			180 90	mV mV
ΔV_o^*	Load Regulation	$I_o = 5$ to 1500 mA $T_j = 25$ °C $I_o = 250$ to 750 mA $T_j = 25$ °C			180 90	mV mV
I_d	Quiescent Current	$T_j = 25$ °C			6	mA
ΔI_d	Quiescent Current Change	$I_o = 5$ to 1000 mA			0.5	mA
ΔI_d	Quiescent Current Change	$V_i = 22$ to 33 V			0.8	mA
$\frac{\Delta V_o}{\Delta T}$	Output Voltage Drift	$I_o = 5$ mA		2.3		mV/°C
eN	Output Noise Voltage	B = 10Hz to 100KHz $T_j = 25$ °C			40	μ V/ V_o
SVR	Supply Voltage Rejection	$V_i = 22$ to 32 V $f = 120$ Hz	59			dB
V_d	Dropout Voltage	$I_o = 1$ A $T_j = 25$ °C		2	2.5	V
R_o	Output Resistance	$f = 1$ KHz		22		m Ω
I_{sc}	Short Circuit Current	$V_i = 35$ V $T_j = 25$ °C		0.75	1.2	A
I_{scp}	Short Circuit Peak Current	$T_j = 25$ °C	1.3	2.2	3.3	A

* Load and line regulation are specified at constant junction temperature. Changes in V_o due to heating effects must be taken into account separately. Pulse testing with low duty cycle is used.

L7800

ELECTRICAL CHARACTERISTICS FOR L7820 (refer to the test circuits, $T_j = -55$ to 150 °C, $V_i = 28$ V, $I_o = 500$ mA, $C_i = 0.33$ μ F, $C_o = 0.1$ μ F unless otherwise specified)

Symbol	Parameter	Test Conditions	Min.	Typ.	Max.	Unit
V_o	Output Voltage	$T_j = 25$ °C	19.2	20	20.8	V
V_o	Output Voltage	$I_o = 5$ mA to 1 A $P_o \leq 15$ W $V_i = 24$ to 35 V	19	20	21	V
ΔV_o^*	Line Regulation	$V_i = 22.5$ to 35 V $T_j = 25$ °C $V_i = 26$ to 32 V $T_j = 25$ °C			200 100	mV mV
ΔV_o^*	Load Regulation	$I_o = 5$ to 1500 mA $T_j = 25$ °C $I_o = 250$ to 750 mA $T_j = 25$ °C			200 100	mV mV
I_d	Quiescent Current	$T_j = 25$ °C			6	mA
ΔI_d	Quiescent Current Change	$I_o = 5$ to 1000 mA			0.5	mA
ΔI_d	Quiescent Current Change	$V_i = 24$ to 35 V			0.8	mA
$\frac{\Delta V_o}{\Delta T}$	Output Voltage Drift	$I_o = 5$ mA		2.5		mV/°C
eN	Output Noise Voltage	$B = 10$ Hz to 100 KHz $T_j = 25$ °C			40	μ V/ V_o
SVR	Supply Voltage Rejection	$V_i = 24$ to 35 V $f = 120$ Hz	58			dB
V_d	Dropout Voltage	$I_o = 1$ A $T_j = 25$ °C		2	2.5	V
R_o	Output Resistance	$f = 1$ KHz		24		m Ω
I_{sc}	Short Circuit Current	$V_i = 35$ V $T_j = 25$ °C		0.75	1.2	A
I_{scp}	Short Circuit Peak Current	$T_j = 25$ °C	1.3	2.2	3.3	A

ELECTRICAL CHARACTERISTICS FOR L7824 (refer to the test circuits, $T_j = -55$ to 150 °C, $V_i = 33$ V, $I_o = 500$ mA, $C_i = 0.33$ μ F, $C_o = 0.1$ μ F unless otherwise specified)

Symbol	Parameter	Test Conditions	Min.	Typ.	Max.	Unit
V_o	Output Voltage	$T_j = 25$ °C	23	24	25	V
V_o	Output Voltage	$I_o = 5$ mA to 1 A $P_o \leq 15$ W $V_i = 28$ to 38 V	22.8	24	25.2	V
ΔV_o^*	Line Regulation	$V_i = 27$ to 38 V $T_j = 25$ °C $V_i = 30$ to 36 V $T_j = 25$ °C			240 120	mV mV
ΔV_o^*	Load Regulation	$I_o = 5$ to 1500 mA $T_j = 25$ °C $I_o = 250$ to 750 mA $T_j = 25$ °C			240 120	mV mV
I_d	Quiescent Current	$T_j = 25$ °C			6	mA
ΔI_d	Quiescent Current Change	$I_o = 5$ to 1000 mA			0.5	mA
ΔI_d	Quiescent Current Change	$V_i = 28$ to 38 V			0.8	mA
$\frac{\Delta V_o}{\Delta T}$	Output Voltage Drift	$I_o = 5$ mA		3		mV/°C
eN	Output Noise Voltage	$B = 10$ Hz to 100 KHz $T_j = 25$ °C			40	μ V/ V_o
SVR	Supply Voltage Rejection	$V_i = 28$ to 38 V $f = 120$ Hz	56			dB
V_d	Dropout Voltage	$I_o = 1$ A $T_j = 25$ °C		2	2.5	V
R_o	Output Resistance	$f = 1$ KHz		28		m Ω
I_{sc}	Short Circuit Current	$V_i = 35$ V $T_j = 25$ °C		0.75	1.2	A
I_{scp}	Short Circuit Peak Current	$T_j = 25$ °C	1.3	2.2	3.3	A

* Load and line regulation are specified at constant junction temperature. Changes in V_o due to heating effects must be taken into account separately. Pulse testing with low duty cycle is used.

L7800

ELECTRICAL CHARACTERISTICS FOR L7805C (refer to the test circuits, $T_j = 0$ to 125 °C, $V_i = 10$ V, $I_o = 500$ mA, $C_i = 0.33$ μ F, $C_o = 0.1$ μ F unless otherwise specified)

Symbol	Parameter	Test Conditions	Min.	Typ.	Max.	Unit
V_o	Output Voltage	$T_j = 25$ °C	4.8	5	5.2	V
V_o	Output Voltage	$I_o = 5$ mA to 1 A $P_o \leq 15$ W $V_i = 7$ to 20 V	4.75	5	5.25	V
ΔV_o^*	Line Regulation	$V_i = 7$ to 25 V $T_j = 25$ °C $V_i = 8$ to 12 V $T_j = 25$ °C		3 1	100 50	mV mV
ΔV_o^*	Load Regulation	$I_o = 5$ to 1500 mA $T_j = 25$ °C $I_o = 250$ to 750 mA $T_j = 25$ °C			100 50	mV mV
I_d	Quiescent Current	$T_j = 25$ °C			8	mA
ΔI_d	Quiescent Current Change	$I_o = 5$ to 1000 mA			0.5	mA
ΔI_d	Quiescent Current Change	$V_i = 7$ to 25 V			0.8	mA
$\frac{\Delta V_o}{\Delta T}$	Output Voltage Drift	$I_o = 5$ mA		-1.1		mV/°C
eN	Output Noise Voltage	B = 10Hz to 100KHz $T_j = 25$ °C		40		μ V
SVR	Supply Voltage Rejection	$V_i = 8$ to 18 V $f = 120$ Hz	62			dB
V_d	Dropout Voltage	$I_o = 1$ A $T_j = 25$ °C		2		V
R_o	Output Resistance	$f = 1$ KHz		17		m Ω
I_{sc}	Short Circuit Current	$V_i = 35$ V $T_j = 25$ °C		750		mA
I_{scp}	Short Circuit Peak Current	$T_j = 25$ °C		2.2		A

ELECTRICAL CHARACTERISTICS FOR L7852C (refer to the test circuits, $T_j = 0$ to 125 °C, $V_i = 10$ V, $I_o = 500$ mA, $C_i = 0.33$ μ F, $C_o = 0.1$ μ F unless otherwise specified)

Symbol	Parameter	Test Conditions	Min.	Typ.	Max.	Unit
V_o	Output Voltage	$T_j = 25$ °C	5.0	5.2	5.4	V
V_o	Output Voltage	$I_o = 5$ mA to 1 A $P_o \leq 15$ W $V_i = 8$ to 20 V	4.95	5.2	5.45	V
ΔV_o^*	Line Regulation	$V_i = 7$ to 25 V $T_j = 25$ °C $V_i = 8$ to 12 V $T_j = 25$ °C		3 1	105 52	mV mV
ΔV_o^*	Load Regulation	$I_o = 5$ to 1500 mA $T_j = 25$ °C $I_o = 250$ to 750 mA $T_j = 25$ °C			105 52	mV mV
I_d	Quiescent Current	$T_j = 25$ °C			8	mA
ΔI_d	Quiescent Current Change	$I_o = 5$ to 1000 mA			0.5	mA
ΔI_d	Quiescent Current Change	$V_i = 7$ to 25 V			1.3	mA
$\frac{\Delta V_o}{\Delta T}$	Output Voltage Drift	$I_o = 5$ mA		-1.0		mV/°C
eN	Output Noise Voltage	B = 10Hz to 100KHz $T_j = 25$ °C		42		μ V
SVR	Supply Voltage Rejection	$V_i = 8$ to 18 V $f = 120$ Hz	61			dB
V_d	Dropout Voltage	$I_o = 1$ A $T_j = 25$ °C		2		V
R_o	Output Resistance	$f = 1$ KHz		17		m Ω
I_{sc}	Short Circuit Current	$V_i = 35$ V $T_j = 25$ °C		750		mA
I_{scp}	Short Circuit Peak Current	$T_j = 25$ °C		2.2		A

* Load and line regulation are specified at constant junction temperature. Changes in V_o due to heating effects must be taken into account separately. Pulse testing with low duty cycle is used.

L7800

ELECTRICAL CHARACTERISTICS FOR L7806C (refer to the test circuits, $T_j = 0$ to 125 °C, $V_i = 11$ V, $I_o = 500$ mA, $C_i = 0.33$ μ F, $C_o = 0.1$ μ F unless otherwise specified)

Symbol	Parameter	Test Conditions	Min.	Typ.	Max.	Unit
V_o	Output Voltage	$T_j = 25$ °C	5.75	6	6.25	V
V_o	Output Voltage	$I_o = 5$ mA to 1 A $P_o \leq 15$ W $V_i = 8$ to 21 V	5.7	6	6.3	V
ΔV_o^*	Line Regulation	$V_i = 8$ to 25 V $T_j = 25$ °C $V_i = 9$ to 13 V $T_j = 25$ °C			120 60	mV mV
ΔV_o^*	Load Regulation	$I_o = 5$ to 1500 mA $T_j = 25$ °C $I_o = 250$ to 750 mA $T_j = 25$ °C			120 60	mV mV
I_d	Quiescent Current	$T_j = 25$ °C			8	mA
ΔI_d	Quiescent Current Change	$I_o = 5$ to 1000 mA			0.5	mA
ΔI_d	Quiescent Current Change	$V_i = 8$ to 25 V			1.3	mA
$\frac{\Delta V_o}{\Delta T}$	Output Voltage Drift	$I_o = 5$ mA		-0.8		mV/°C
eN	Output Noise Voltage	$B = 10$ Hz to 100 KHz $T_j = 25$ °C		45		μ V
SVR	Supply Voltage Rejection	$V_i = 9$ to 19 V $f = 120$ Hz	59			dB
V_d	Dropout Voltage	$I_o = 1$ A $T_j = 25$ °C		2		V
R_o	Output Resistance	$f = 1$ KHz		19		m Ω
I_{sc}	Short Circuit Current	$V_i = 35$ V $T_j = 25$ °C		550		mA
I_{scp}	Short Circuit Peak Current	$T_j = 25$ °C		2.2		A

ELECTRICAL CHARACTERISTICS FOR L7808C (refer to the test circuits, $T_j = 0$ to 125 °C, $V_i = 14$ V, $I_o = 500$ mA, $C_i = 0.33$ μ F, $C_o = 0.1$ μ F unless otherwise specified)

Symbol	Parameter	Test Conditions	Min.	Typ.	Max.	Unit
V_o	Output Voltage	$T_j = 25$ °C	7.7	8	8.3	V
V_o	Output Voltage	$I_o = 5$ mA to 1 A $P_o \leq 15$ W $V_i = 10.5$ to 25 V	7.6	8	8.4	V
ΔV_o^*	Line Regulation	$V_i = 10.5$ to 25 V $T_j = 25$ °C $V_i = 11$ to 17 V $T_j = 25$ °C			160 80	mV mV
ΔV_o^*	Load Regulation	$I_o = 5$ to 1500 mA $T_j = 25$ °C $I_o = 250$ to 750 mA $T_j = 25$ °C			160 80	mV mV
I_d	Quiescent Current	$T_j = 25$ °C			8	mA
ΔI_d	Quiescent Current Change	$I_o = 5$ to 1000 mA			0.5	mA
ΔI_d	Quiescent Current Change	$V_i = 10.5$ to 25 V			1	mA
$\frac{\Delta V_o}{\Delta T}$	Output Voltage Drift	$I_o = 5$ mA		-0.8		mV/°C
eN	Output Noise Voltage	$B = 10$ Hz to 100 KHz $T_j = 25$ °C		52		μ V
SVR	Supply Voltage Rejection	$V_i = 11.5$ to 21.5 V $f = 120$ Hz	56			dB
V_d	Dropout Voltage	$I_o = 1$ A $T_j = 25$ °C		2		V
R_o	Output Resistance	$f = 1$ KHz		16		m Ω
I_{sc}	Short Circuit Current	$V_i = 35$ V $T_j = 25$ °C		450		mA
I_{scp}	Short Circuit Peak Current	$T_j = 25$ °C		2.2		A

* Load and line regulation are specified at constant junction temperature. Changes in V_o due to heating effects must be taken into account separately. Pulse testing with low duty cycle is used.

L7800

ELECTRICAL CHARACTERISTICS FOR L7885C (refer to the test circuits, $T_j = 0$ to 125 °C, $V_i = 14.5$ V, $I_o = 500$ mA, $C_i = 0.33$ μ F, $C_o = 0.1$ μ F unless otherwise specified)

Symbol	Parameter	Test Conditions	Min.	Typ.	Max.	Unit
V_o	Output Voltage	$T_j = 25$ °C	8.2	8.5	8.8	V
V_o	Output Voltage	$I_o = 5$ mA to 1 A $P_o \leq 15$ W $V_i = 11$ to 26 V	8.1	8.5	8.9	V
ΔV_o^*	Line Regulation	$V_i = 11$ to 27 V $T_j = 25$ °C $V_i = 11.5$ to 17.5 V $T_j = 25$ °C			160 80	mV mV
ΔV_o^*	Load Regulation	$I_o = 5$ to 1500 mA $T_j = 25$ °C $I_o = 250$ to 750 mA $T_j = 25$ °C			160 80	mV mV
I_d	Quiescent Current	$T_j = 25$ °C			8	mA
ΔI_d	Quiescent Current Change	$I_o = 5$ to 1000 mA			0.5	mA
ΔI_d	Quiescent Current Change	$V_i = 11$ to 27 V			1	mA
$\frac{\Delta V_o}{\Delta T}$	Output Voltage Drift	$I_o = 5$ mA		-0.8		mV/°C
eN	Output Noise Voltage	B = 10Hz to 100KHz $T_j = 25$ °C		55		μ V
SVR	Supply Voltage Rejection	$V_i = 12$ to 22 V $f = 120$ Hz	56			dB
V_d	Dropout Voltage	$I_o = 1$ A $T_j = 25$ °C		2		V
R_o	Output Resistance	$f = 1$ KHz		16		m Ω
I_{sc}	Short Circuit Current	$V_i = 35$ V $T_j = 25$ °C		450		mA
I_{scp}	Short Circuit Peak Current	$T_j = 25$ °C		2.2		A

ELECTRICAL CHARACTERISTICS FOR L7809C (refer to the test circuits, $T_j = 0$ to 125 °C, $V_i = 15$ V, $I_o = 500$ mA, $C_i = 0.33$ μ F, $C_o = 0.1$ μ F unless otherwise specified)

Symbol	Parameter	Test Conditions	Min.	Typ.	Max.	Unit
V_o	Output Voltage	$T_j = 25$ °C	8.65	9	9.35	V
V_o	Output Voltage	$I_o = 5$ mA to 1 A $P_o \leq 15$ W $V_i = 11.5$ to 26 V	8.55	9	9.45	V
ΔV_o^*	Line Regulation	$V_i = 11.5$ to 26 V $T_j = 25$ °C $V_i = 12$ to 18 V $T_j = 25$ °C			180 90	mV mV
ΔV_o^*	Load Regulation	$I_o = 5$ to 1500 mA $T_j = 25$ °C $I_o = 250$ to 750 mA $T_j = 25$ °C			180 90	mV mV
I_d	Quiescent Current	$T_j = 25$ °C			8	mA
ΔI_d	Quiescent Current Change	$I_o = 5$ to 1000 mA			0.5	mA
ΔI_d	Quiescent Current Change	$V_i = 11.5$ to 26 V			1	mA
$\frac{\Delta V_o}{\Delta T}$	Output Voltage Drift	$I_o = 5$ mA		-1.0		mV/°C
eN	Output Noise Voltage	B = 10Hz to 100KHz $T_j = 25$ °C		70		μ V
SVR	Supply Voltage Rejection	$V_i = 12$ to 23 V $f = 120$ Hz	55			dB
V_d	Dropout Voltage	$I_o = 1$ A $T_j = 25$ °C		2		V
R_o	Output Resistance	$f = 1$ KHz		17		m Ω
I_{sc}	Short Circuit Current	$V_i = 35$ V $T_j = 25$ °C		400		mA
I_{scp}	Short Circuit Peak Current	$T_j = 25$ °C		2.2		A

* Load and line regulation are specified at constant junction temperature. Changes in V_o due to heating effects must be taken into account separately. Pulse testing with low duty cycle is used.

L7800

ELECTRICAL CHARACTERISTICS FOR L7812C (refer to the test circuits, $T_j = 0$ to 125 °C, $V_i = 19$ V, $I_o = 500$ mA, $C_i = 0.33$ μ F, $C_o = 0.1$ μ F unless otherwise specified)

Symbol	Parameter	Test Conditions	Min.	Typ.	Max.	Unit
V_o	Output Voltage	$T_j = 25$ °C	11.5	12	12.5	V
V_o	Output Voltage	$I_o = 5$ mA to 1 A $P_o \leq 15$ W $V_i = 14.5$ to 27 V	11.4	12	12.6	V
ΔV_o^*	Line Regulation	$V_i = 14.5$ to 30 V $T_j = 25$ °C $V_i = 16$ to 22 V $T_j = 25$ °C			240 120	mV mV
ΔV_o^*	Load Regulation	$I_o = 5$ to 1500 mA $T_j = 25$ °C $I_o = 250$ to 750 mA $T_j = 25$ °C			240 120	mV mV
I_d	Quiescent Current	$T_j = 25$ °C			8	mA
ΔI_d	Quiescent Current Change	$I_o = 5$ to 1000 mA			0.5	mA
ΔI_d	Quiescent Current Change	$V_i = 14.5$ to 30 V			1	mA
$\frac{\Delta V_o}{\Delta T}$	Output Voltage Drift	$I_o = 5$ mA		-1		mV/°C
eN	Output Noise Voltage	B = 10Hz to 100KHz $T_j = 25$ °C		75		μ V
SVR	Supply Voltage Rejection	$V_i = 15$ to 25 V $f = 120$ Hz	55			dB
V_d	Dropout Voltage	$I_o = 1$ A $T_j = 25$ °C		2		V
R_o	Output Resistance	$f = 1$ KHz		18		m Ω
I_{sc}	Short Circuit Current	$V_i = 35$ V $T_j = 25$ °C		350		mA
I_{scp}	Short Circuit Peak Current	$T_j = 25$ °C		2.2		A

ELECTRICAL CHARACTERISTICS FOR L7815C (refer to the test circuits, $T_j = 0$ to 125 °C, $V_i = 23$ V, $I_o = 500$ mA, $C_i = 0.33$ μ F, $C_o = 0.1$ μ F unless otherwise specified)

Symbol	Parameter	Test Conditions	Min.	Typ.	Max.	Unit
V_o	Output Voltage	$T_j = 25$ °C	14.4	15	15.6	V
V_o	Output Voltage	$I_o = 5$ mA to 1 A $P_o \leq 15$ W $V_i = 17.5$ to 30 V	14.25	15	15.75	V
ΔV_o^*	Line Regulation	$V_i = 17.5$ to 30 V $T_j = 25$ °C $V_i = 20$ to 26 V $T_j = 25$ °C			300 150	mV mV
ΔV_o^*	Load Regulation	$I_o = 5$ to 1500 mA $T_j = 25$ °C $I_o = 250$ to 750 mA $T_j = 25$ °C			300 150	mV mV
I_d	Quiescent Current	$T_j = 25$ °C			8	mA
ΔI_d	Quiescent Current Change	$I_o = 5$ to 1000 mA			0.5	mA
ΔI_d	Quiescent Current Change	$V_i = 17.5$ to 30 V			1	mA
$\frac{\Delta V_o}{\Delta T}$	Output Voltage Drift	$I_o = 5$ mA		-1		mV/°C
eN	Output Noise Voltage	B = 10Hz to 100KHz $T_j = 25$ °C		90		μ V
SVR	Supply Voltage Rejection	$V_i = 18.5$ to 28.5 V $f = 120$ Hz	54			dB
V_d	Dropout Voltage	$I_o = 1$ A $T_j = 25$ °C		2		V
R_o	Output Resistance	$f = 1$ KHz		19		m Ω
I_{sc}	Short Circuit Current	$V_i = 35$ V $T_j = 25$ °C		230		mA
I_{scp}	Short Circuit Peak Current	$T_j = 25$ °C		2.1		A

* Load and line regulation are specified at constant junction temperature. Changes in V_o due to heating effects must be taken into account separately. Pulse testing with low duty cycle is used.

L7800

ELECTRICAL CHARACTERISTICS FOR L7818C (refer to the test circuits, $T_j = 0$ to 125 °C, $V_i = 26$ V, $I_o = 500$ mA, $C_i = 0.33$ μ F, $C_o = 0.1$ μ F unless otherwise specified)

Symbol	Parameter	Test Conditions	Min.	Typ.	Max.	Unit
V_o	Output Voltage	$T_j = 25$ °C	17.3	18	18.7	V
V_o	Output Voltage	$I_o = 5$ mA to 1 A $P_o \leq 15$ W $V_i = 21$ to 33 V	17.1	18	18.9	V
ΔV_o^*	Line Regulation	$V_i = 21$ to 33 V $T_j = 25$ °C $V_i = 24$ to 30 V $T_j = 25$ °C			360 180	mV mV
ΔV_o^*	Load Regulation	$I_o = 5$ to 1500 mA $T_j = 25$ °C $I_o = 250$ to 750 mA $T_j = 25$ °C			360 180	mV mV
I_d	Quiescent Current	$T_j = 25$ °C			8	mA
ΔI_d	Quiescent Current Change	$I_o = 5$ to 1000 mA			0.5	mA
ΔI_d	Quiescent Current Change	$V_i = 21$ to 33 V			1	mA
$\frac{\Delta V_o}{\Delta T}$	Output Voltage Drift	$I_o = 5$ mA		-1		mV/°C
eN	Output Noise Voltage	$B = 10$ Hz to 100 KHz $T_j = 25$ °C		110		μ V
SVR	Supply Voltage Rejection	$V_i = 22$ to 32 V $f = 120$ Hz	53			dB
V_d	Dropout Voltage	$I_o = 1$ A $T_j = 25$ °C		2		V
R_o	Output Resistance	$f = 1$ KHz		22		m Ω
I_{sc}	Short Circuit Current	$V_i = 35$ V $T_j = 25$ °C		200		mA
I_{scp}	Short Circuit Peak Current	$T_j = 25$ °C		2.1		A

ELECTRICAL CHARACTERISTICS FOR L7820C (refer to the test circuits, $T_j = 0$ to 125 °C, $V_i = 28$ V, $I_o = 500$ mA, $C_i = 0.33$ μ F, $C_o = 0.1$ μ F unless otherwise specified)

Symbol	Parameter	Test Conditions	Min.	Typ.	Max.	Unit
V_o	Output Voltage	$T_j = 25$ °C	19.2	20	20.8	V
V_o	Output Voltage	$I_o = 5$ mA to 1 A $P_o \leq 15$ W $V_i = 23$ to 35 V	19	20	21	V
ΔV_o^*	Line Regulation	$V_i = 22.5$ to 35 V $T_j = 25$ °C $V_i = 26$ to 32 V $T_j = 25$ °C			400 200	mV mV
ΔV_o^*	Load Regulation	$I_o = 5$ to 1500 mA $T_j = 25$ °C $I_o = 250$ to 750 mA $T_j = 25$ °C			400 200	mV mV
I_d	Quiescent Current	$T_j = 25$ °C			8	mA
ΔI_d	Quiescent Current Change	$I_o = 5$ to 1000 mA			0.5	mA
ΔI_d	Quiescent Current Change	$V_i = 23$ to 35 V			1	mA
$\frac{\Delta V_o}{\Delta T}$	Output Voltage Drift	$I_o = 5$ mA		-1		mV/°C
eN	Output Noise Voltage	$B = 10$ Hz to 100 KHz $T_j = 25$ °C		150		μ V
SVR	Supply Voltage Rejection	$V_i = 24$ to 35 V $f = 120$ Hz	52			dB
V_d	Dropout Voltage	$I_o = 1$ A $T_j = 25$ °C		2		V
R_o	Output Resistance	$f = 1$ KHz		24		m Ω
I_{sc}	Short Circuit Current	$V_i = 35$ V $T_j = 25$ °C		180		mA
I_{scp}	Short Circuit Peak Current	$T_j = 25$ °C		2.1		A

* Load and line regulation are specified at constant junction temperature. Changes in V_o due to heating effects must be taken into account separately. Pulse testing with low duty cycle is used.

L7800

ELECTRICAL CHARACTERISTICS FOR L7824C (refer to the test circuits, $T_j = 0$ to 125 °C, $V_i = 33$ V, $I_o = 500$ mA, $C_i = 0.33$ μ F, $C_o = 0.1$ μ F unless otherwise specified)

Symbol	Parameter	Test Conditions	Min.	Typ.	Max.	Unit
V_o	Output Voltage	$T_j = 25$ °C	23	24	25	V
V_o	Output Voltage	$I_o = 5$ mA to 1 A $P_o \leq 15$ W $V_i = 27$ to 38 V	22.8	24	25.2	V
ΔV_o^*	Line Regulation	$V_i = 27$ to 38 V $T_j = 25$ °C $V_i = 30$ to 36 V $T_j = 25$ °C			480 240	mV mV
ΔV_o^*	Load Regulation	$I_o = 5$ to 1500 mA $T_j = 25$ °C $I_o = 250$ to 750 mA $T_j = 25$ °C			480 240	mV mV
I_d	Quiescent Current	$T_j = 25$ °C			8	mA
ΔI_d	Quiescent Current Change	$I_o = 5$ to 1000 mA			0.5	mA
ΔI_d	Quiescent Current Change	$V_i = 27$ to 38 V			1	mA
$\frac{\Delta V_o}{\Delta T}$	Output Voltage Drift	$I_o = 5$ mA		-1.5		mV/°C
eN	Output Noise Voltage	$B = 10$ Hz to 100 KHz $T_j = 25$ °C		170		μ V
SVR	Supply Voltage Rejection	$V_i = 28$ to 38 V $f = 120$ Hz	50			dB
V_d	Dropout Voltage	$I_o = 1$ A $T_j = 25$ °C		2		V
R_o	Output Resistance	$f = 1$ KHz		28		m Ω
I_{sc}	Short Circuit Current	$V_i = 35$ V $T_j = 25$ °C		150		mA
I_{scp}	Short Circuit Peak Current	$T_j = 25$ °C		2.1		A

* Load and line regulation are specified at constant junction temperature. Changes in V_o due to heating effects must be taken into account separately. Pulse testing with low duty cycle is used.

Electrónica S.A. de C.V.

Figure 4 : Dropout Voltage vs. Junction Temperature.

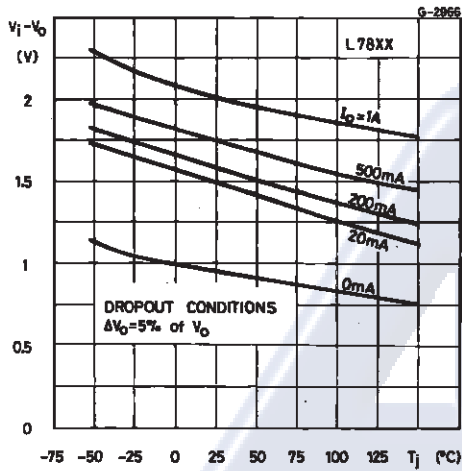

Figure 5 : Peak Output Current vs. Input/output Differential Voltage.

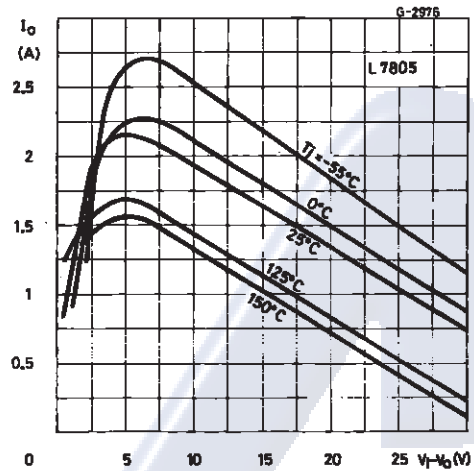

Figure 6 : Supply Voltage Rejection vs. Frequency.

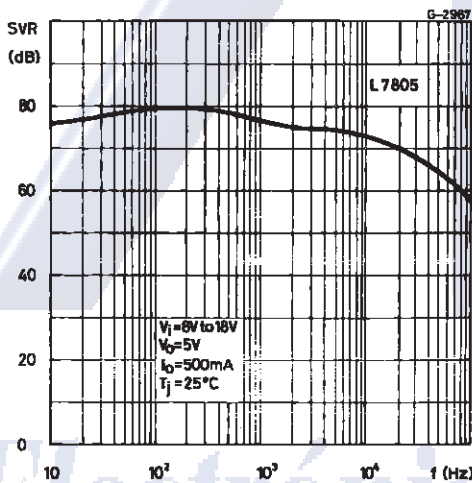

Figure 7 : Output Voltage vs. Junction Temperature.

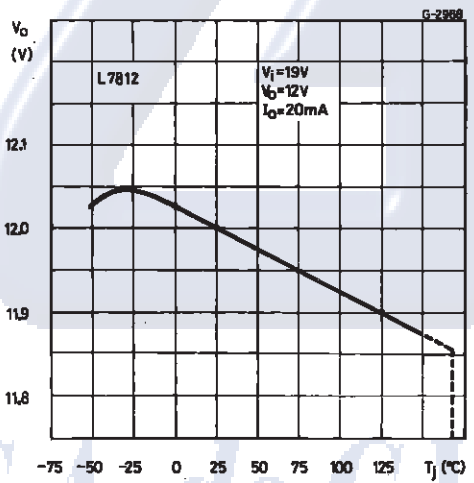

Figure 8 : Output Impedance vs. Frequency.

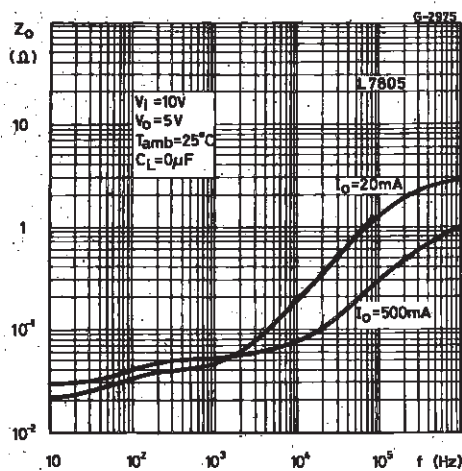
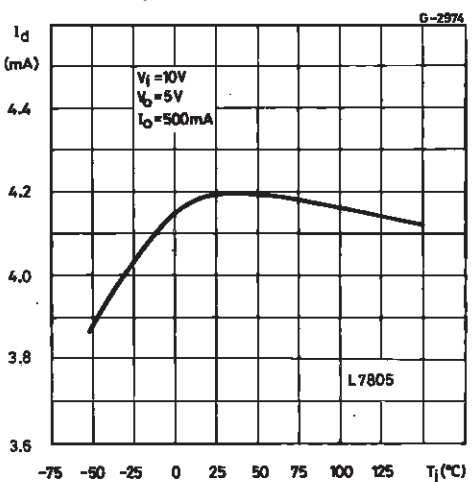

Figure 9 : Quiescent Current vs. Junction Temperature.



L7800

Figure 10 : Load Transient Response.

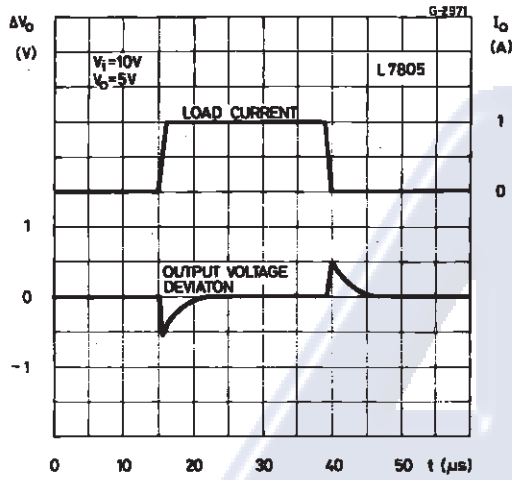

Figure 11 : Line Transient Response.

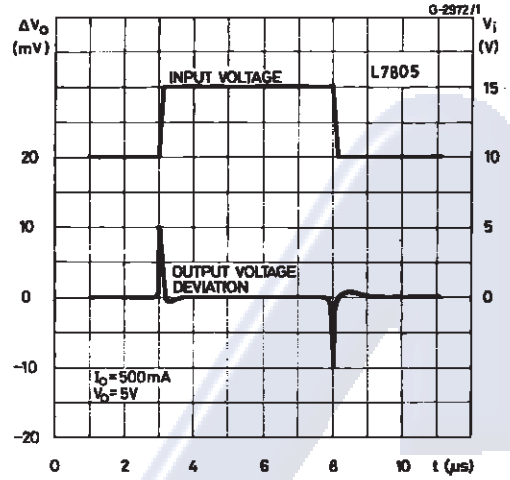

Figure 12 : Quiescent Current vs. Input Voltage.

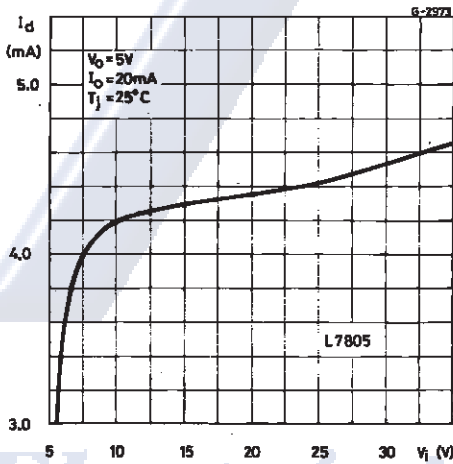

Figure 13 : Fixed Output Regulator.

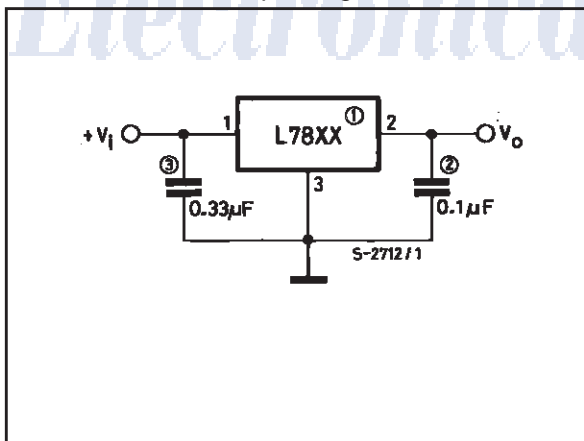
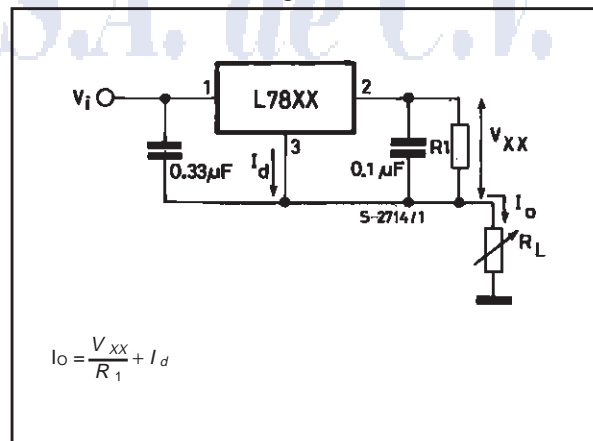

Figure 14 : Current Regulator.



NOTE:

1. To specify an output voltage, substitute voltage value for "XX".
2. Although no output capacitor is need for stability, it does improve transient response.
3. Required if cregulator is locate an appreciable distance from power supply filter.



Figure 15 : Circuit for Increasing Output Voltage.

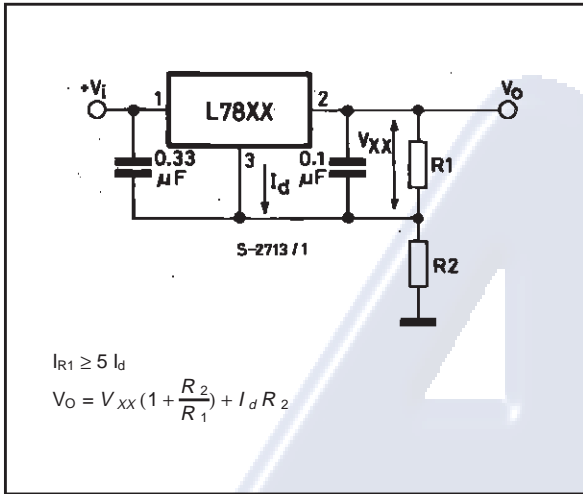

Figure 16 : Adjustable Output Regulator (7 to 30V).

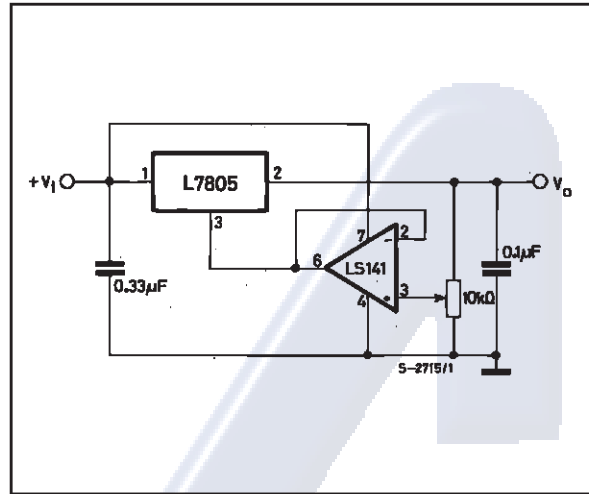

Figure 17 : 0.5 to 10V Regulator.

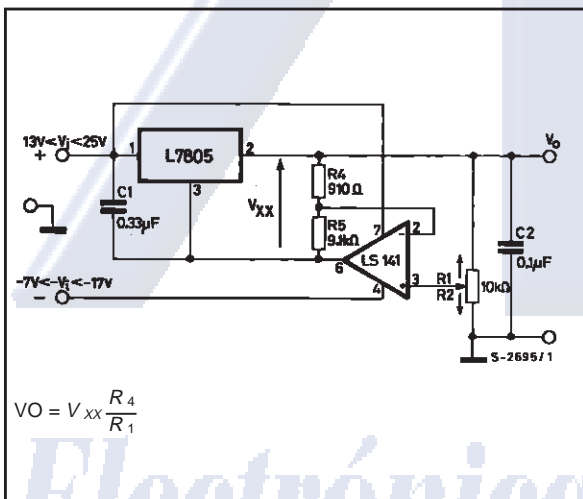
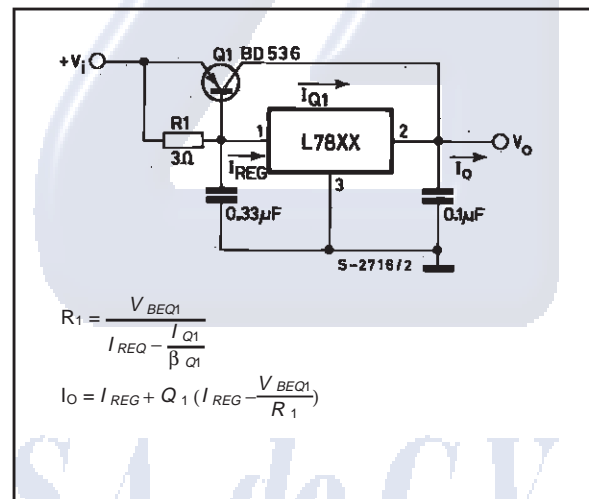

Figure 18 : High Current Voltage Regulator.



L7800

Figure 19 : High Output Current with Short Circuit Protection.

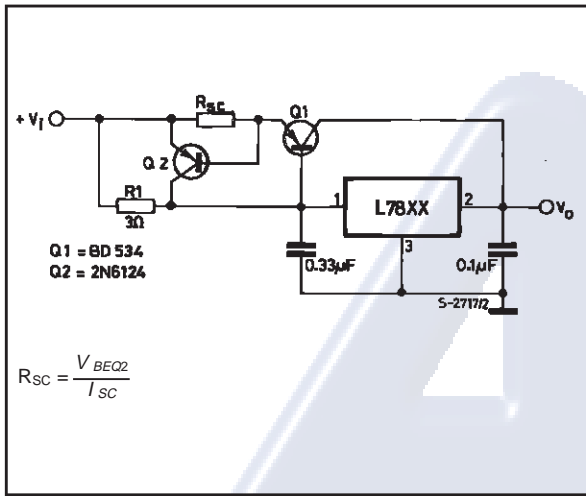

Figure 20 : Tracking Voltage Regulator.

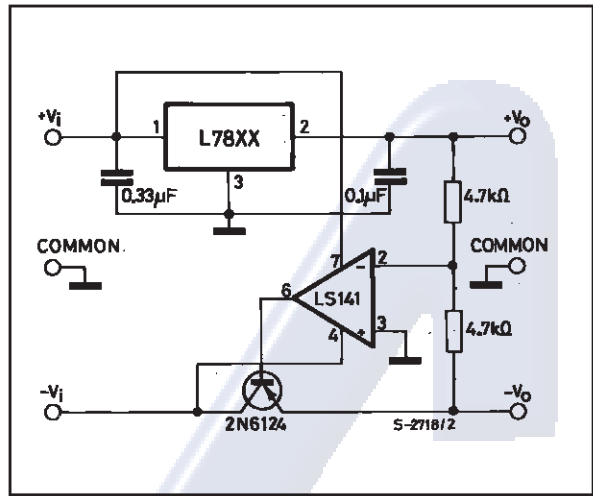
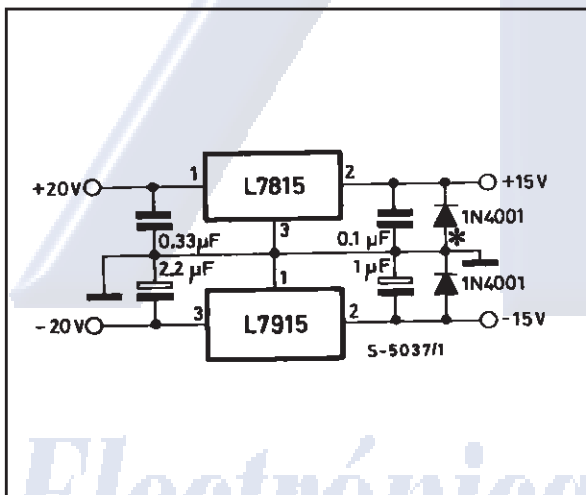

Figure 21 : Split Power Supply (± 15V – 1A).



* Against potential latch-up problems.

Figure 22 : Negative Output Voltage Circuit.

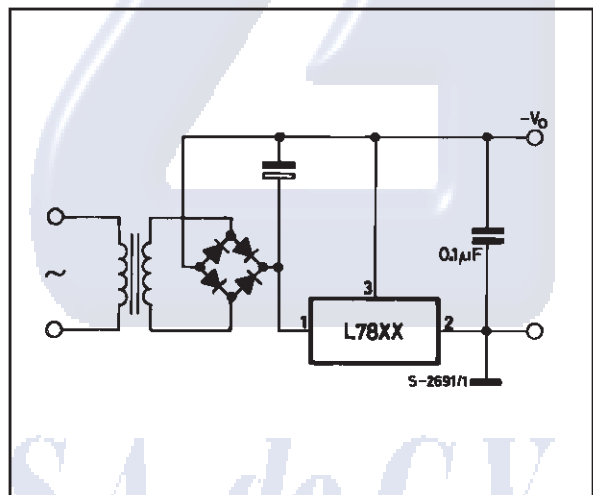

Figure 23 : Switching Regulator.

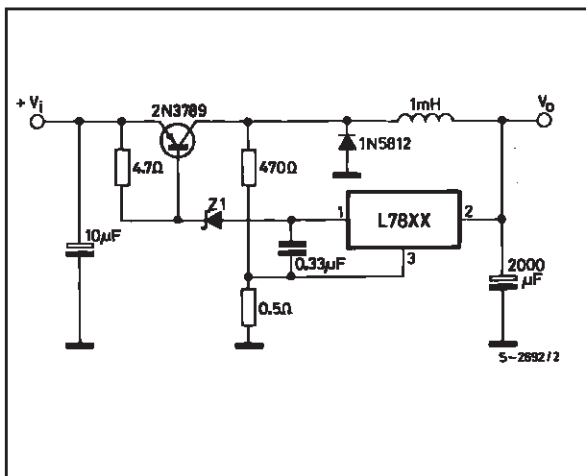

Figure 24 : High Input Voltage Circuit.

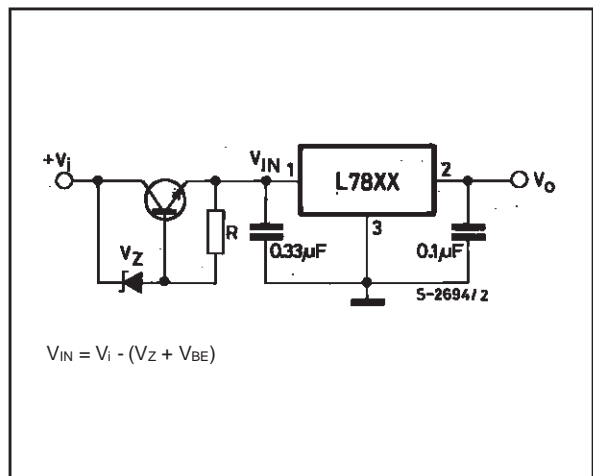

Figure 25 : High Input Voltage Circuit.

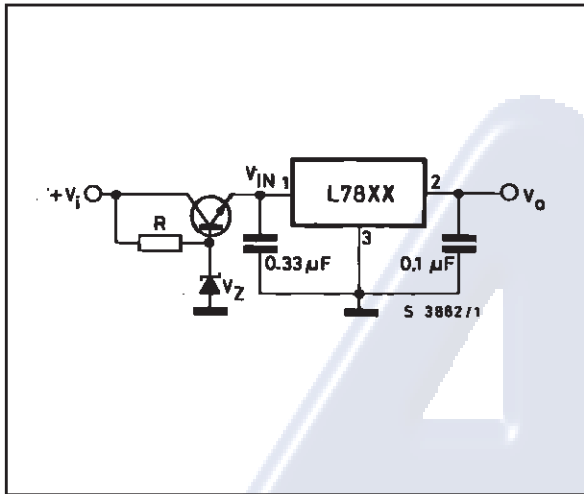

Figure 26 : High Output Voltage Regulator.

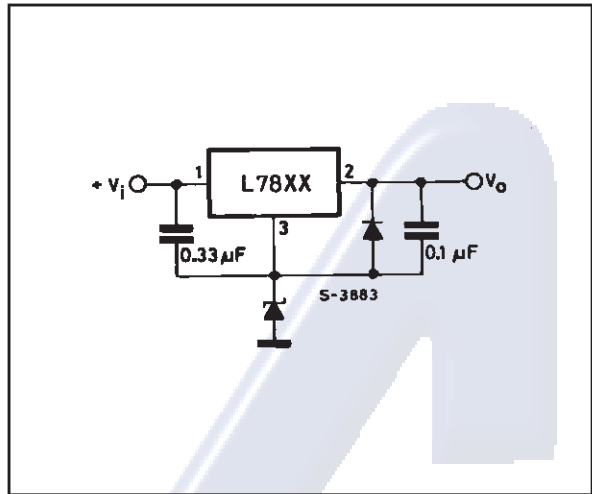

Figure 27 : High Input and Output Voltage.

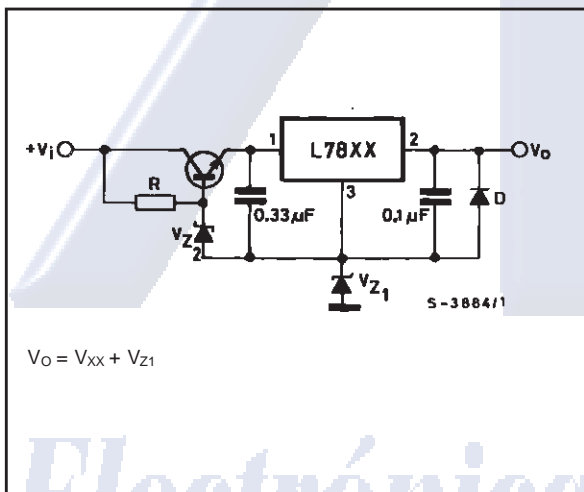

Figure 28 : Reducing Power Dissipation with Dropping Resistor.

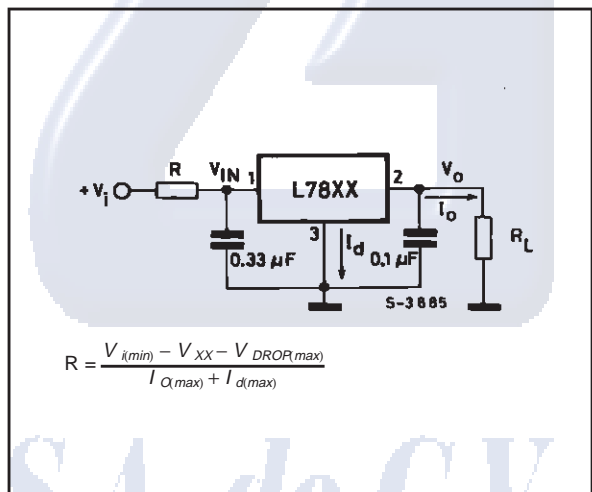
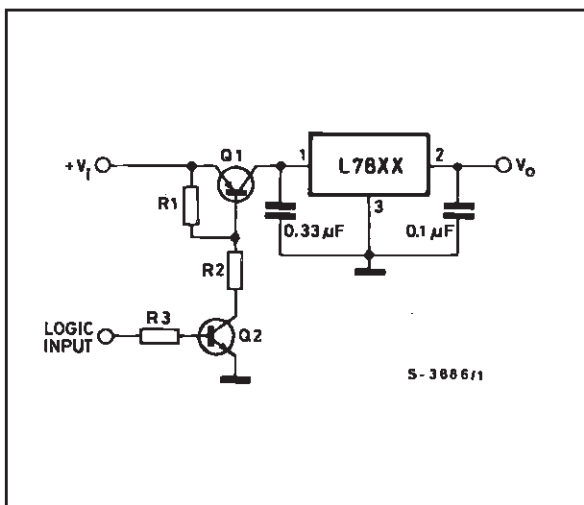
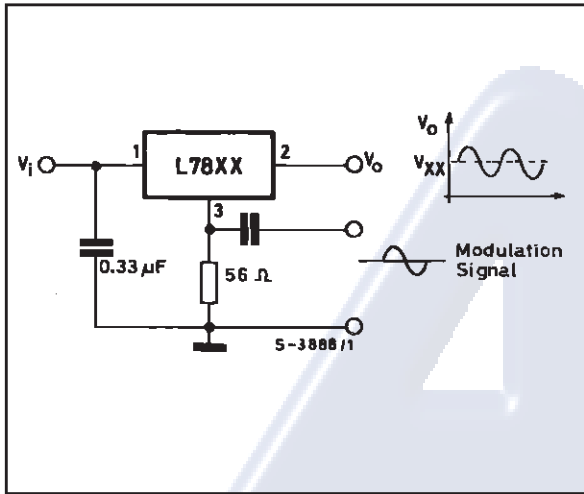

Figure 29 : Remote Shutdown.



L7800

Figure 30 : Power AM Modulator (unity voltage gain, $I_o < 1A$).



NOTE: The circuit performs well up to 100KHz

Figure 31 : Adjustable Output Voltage with Temperature Compensation.

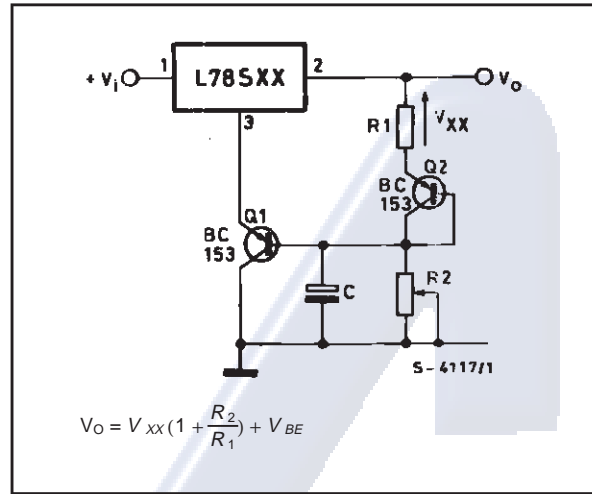

$$V_o = V_{XX} \left(1 + \frac{R_2}{R_1}\right) + V_{BE}$$

NOTE: Q₂ is connected as a diode in order to compensate the variation of the Q₁ V_{BE} with the temperature. C allows a slow rise-time of the V_o.

Figure 32 : Light Controllers ($V_o \text{ min} = V_{XX} + V_{BE}$).

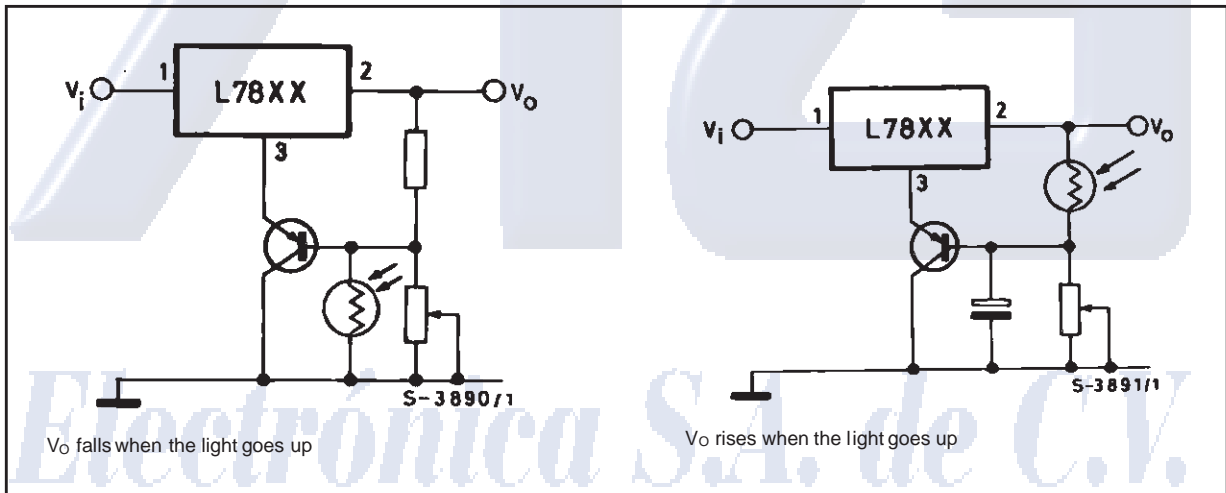
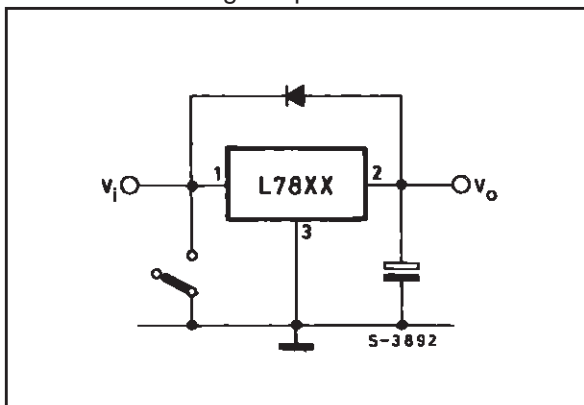

Figure 33 : Protection against Input Short-circuit with High Capacitance Loads.



Application with high capacitance loads and an output voltage greater than 6 volts need an external diode (see fig. 33) to protect the device against input short circuit. In this case the input voltage falls rapidly while the output voltage decrease slowly. The capacitance discharges by means of the Base-Emitter junction of the series pass transistor in the regulator. If the energy is sufficiently high, the transistor may be destroyed. The external diode by-passes the current from the IC to ground.

L7800

TO-3 (R) MECHANICAL DATA

DIM.	mm			inch		
	MIN.	TYP.	MAX.	MIN.	TYP.	MAX.
A		11.7			0.460	
B	0.96		1.10	0.037		0.043
C			1.70			0.066
D			8.7			0.342
E			20.0			0.787
G		10.9			0.429	
N		16.9			0.665	
P			26.2			1.031
R	3.88		4.09	0.152		0.161
U			39.50			1.555
V		30.10			1.185	

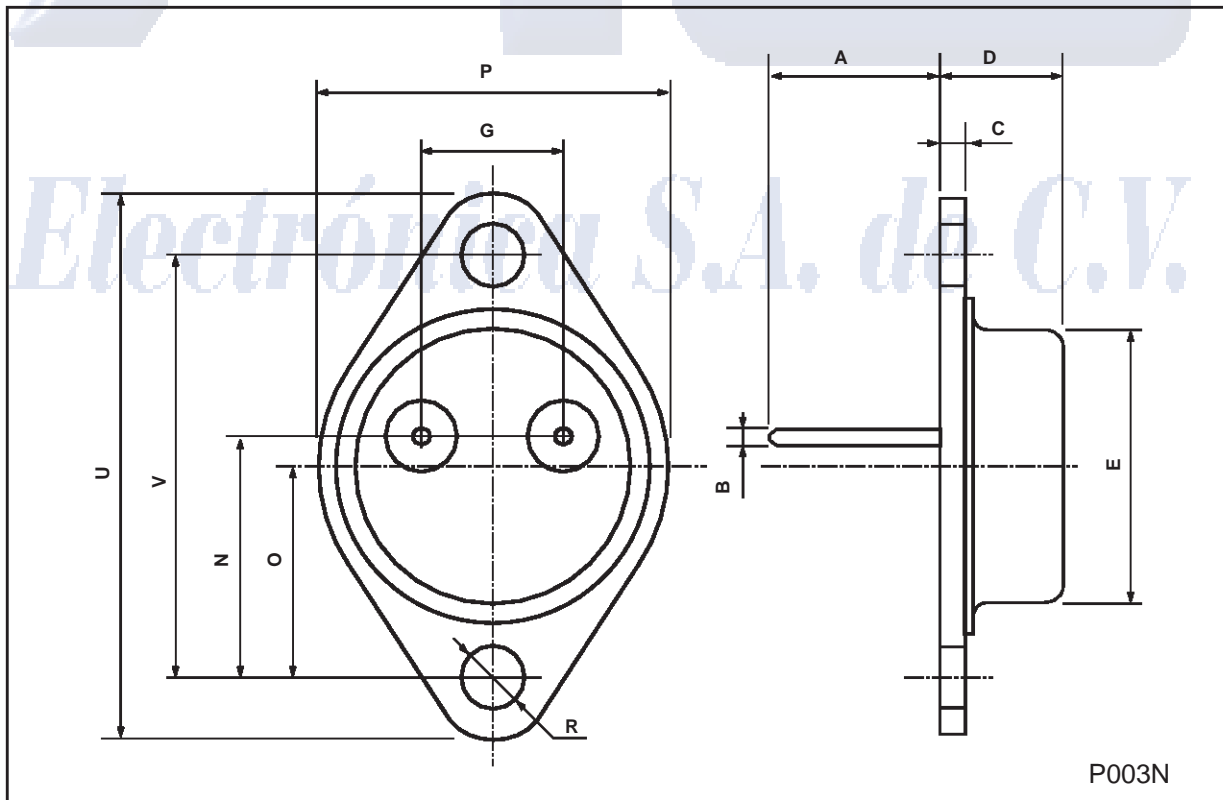

L7800

TO-220 MECHANICAL DATA

DIM.	mm			inch		
	MIN.	TYP.	MAX.	MIN.	TYP.	MAX.
A	4.40		4.60	0.173		0.181
C	1.23		1.32	0.048		0.051
D	2.40		2.72	0.094		0.107
D1		1.27			0.050	
E	0.49		0.70	0.019		0.027
F	0.61		0.88	0.024		0.034
F1	1.14		1.70	0.044		0.067
F2	1.14		1.70	0.044		0.067
G	4.95		5.15	0.194		0.203
G1	2.4		2.7	0.094		0.106
H2	10.0		10.40	0.393		0.409
L2		16.4			0.645	
L4	13.0		14.0	0.511		0.551
L5	2.65		2.95	0.104		0.116
L6	15.25		15.75	0.600		0.620
L7	6.2		6.6	0.244		0.260
L9	3.5		3.93	0.137		0.154
DIA.	3.75		3.85	0.147		0.151

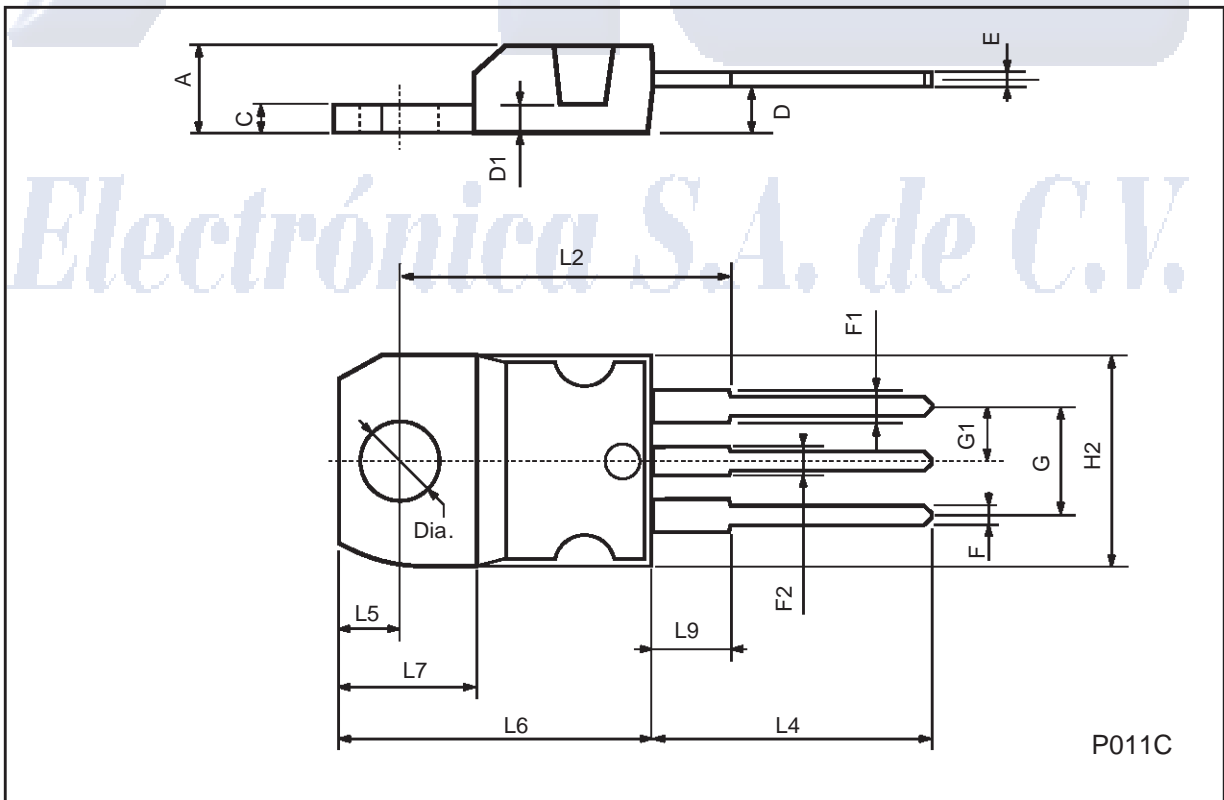

L7800

TO-220FP MECHANICAL DATA

DIM.	mm			inch		
	MIN.	TYP.	MAX.	MIN.	TYP.	MAX.
A	4.4		4.6	0.173		0.181
B	2.5		2.7	0.098		0.106
D	2.5		2.75	0.098		0.108
E	0.45		0.7	0.017		0.027
F	0.75		1	0.030		0.039
F1	1.15		1.7	0.045		0.067
F2	1.15		1.7	0.045		0.067
G	4.95		5.2	0.195		0.204
G1	2.4		2.7	0.094		0.106
H	10		10.4	0.393		0.409
L2		16			0.630	
L3	28.6		30.6	1.126		1.204
L4	9.8		10.6	0.385		0.417
L6	15.9		16.4	0.626		0.645
L7	9		9.3	0.354		0.366
Ø	3		3.2	0.118		0.126

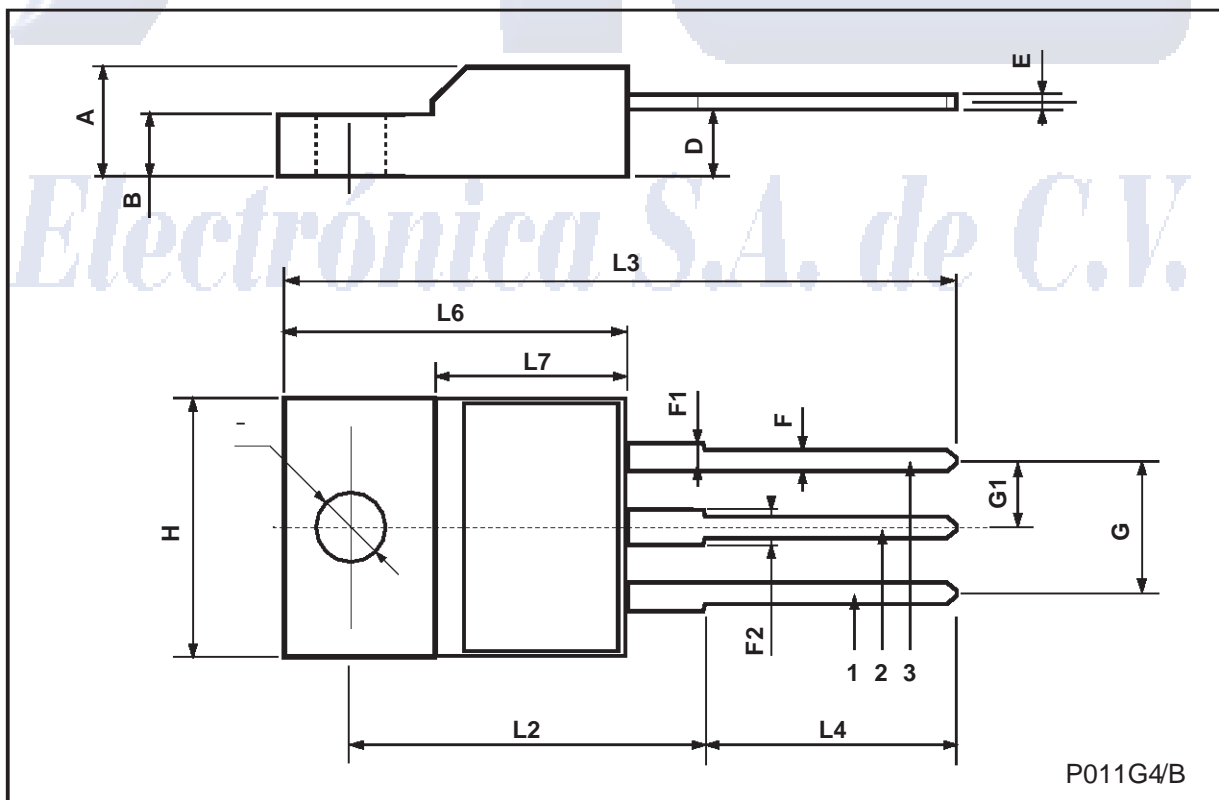

L7800

TO-263 (D²PAK) MECHANICAL DATA

DIM.	mm			inch		
	MIN.	TYP.	MAX.	MIN.	TYP.	MAX.
A	4.4		4.6	0.173		0.181
A1	2.49		2.69	0.098		0.106
B	0.7		0.93	0.027		0.036
B2	1.14		1.7	0.044		0.067
C	0.45		0.6	0.017		0.023
C2	1.23		1.36	0.048		0.053
D	8.95		9.35	0.352		0.368
E	10		10.4	0.393		0.409
G	4.88		5.28	0.192		0.208
L	15		15.85	0.590		0.624
L2	1.27		1.4	0.050		0.055
L3	1.4		1.75	0.055		0.068

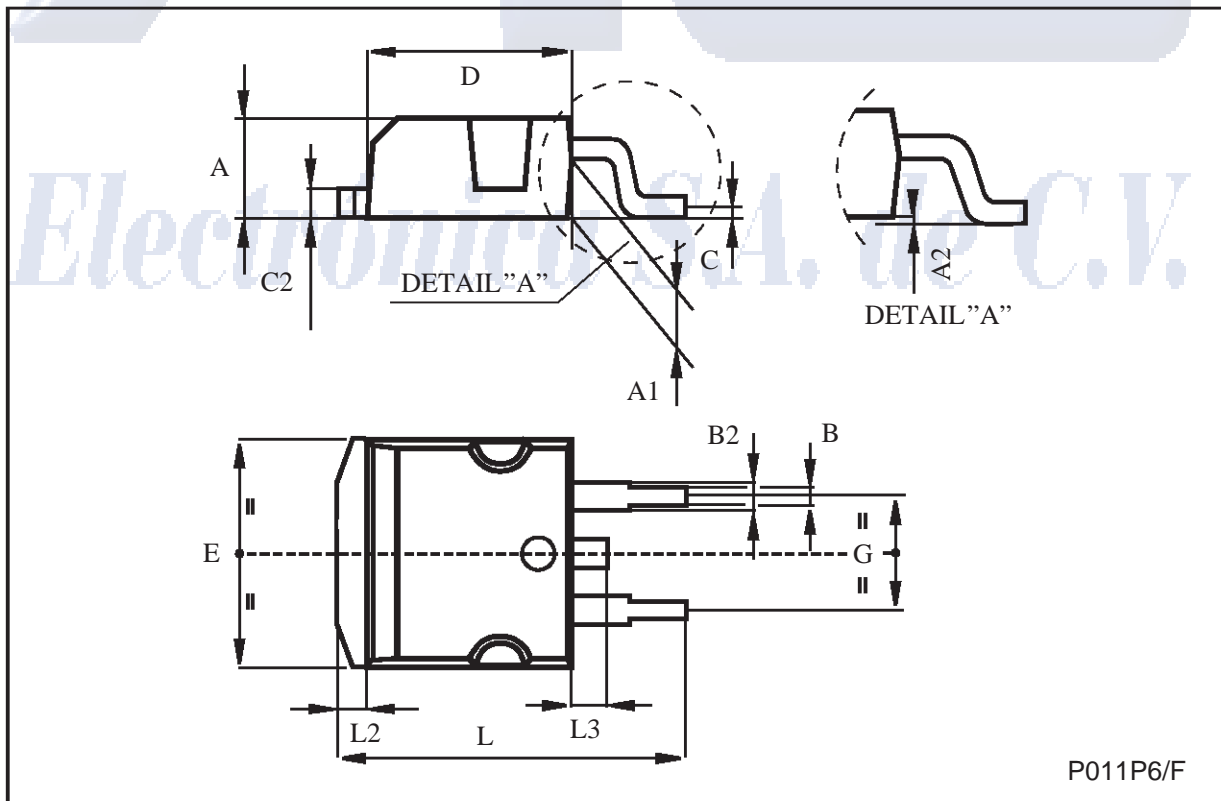

AAG

Electrónica S.A. de C.V.

Information furnished is believed to be accurate and reliable. However, STMicroelectronics assumes no responsibility for the consequences of use of such information nor for any infringement of patents or other rights of third parties which may result from its use. No license is granted by implication or otherwise under any patent or patent rights of STMicroelectronics. Specification mentioned in this publication are subject to change without notice. This publication supersedes and replaces all information previously supplied. STMicroelectronics products are not authorized for use as critical components in life support devices or systems without express written approval of STMicroelectronics.

The ST logo is a registered trademark of STMicroelectronics

© 2000 STMicroelectronics – Printed in Italy – All Rights Reserved
STMicroelectronics GROUP OF COMPANIES

Australia - Brazil - China - Finland - France - Germany - Hong Kong - India - Italy - Japan - Malaysia - Malta - Morocco
Singapore - Spain - Sweden - Switzerland - United Kingdom - U.S.A.

<http://www.st.com>

