

Monolithic Linear IC



No.494F

LA3160

2-Channel Preamplifier For Car Stereo

Features

- . Two preamplifiers on chip
- . Fewer peripheral parts.
- . Low noise.
- . 8-pin SIP package facilitating easy mounting.

Maximum Ratings at Ta = 25°C

			unit
Maximum Supply Voltage	V _{CCmax}	18	V
Allowable Power Dissipation	P _{dmax}	200	mW
Operating Temperature	T _{opr}	-20 to +75	°C
Storage Temperature	T _{stg}	-40 to +125	°C

Recommended Operating Conditions at Ta = 25°C

			unit
Supply Voltage	V _{CC}	9	V
Load Resistance	R _L	10k	Ω

Operating Characteristics at Ta = 25°C, V_{CC} = 9V, R_L = 10kΩ, R_g = 600Ω, f = 1kHz, NAB

			min	typ	max	unit
Current Dissipation	I _{CC}			4	6	mA
Voltage Gain	V _G	Closed loop		35		dB
		Open loop, v _o = 0.77V	76	80		dB
Output Voltage	v _o	THD = 1%	1.1	1.8		V
Total Harmonic Distortion	THD	v _o = 0.5V		0.1	0.3	%
Input Resistance	r _i		70k	100k		Ω
Equivalent Input Noise Voltage	V _{NI}	R _g = 2.2kΩ		1.25	2.0	μV
Crosstalk	CT		-50	-65		dB

Equivalent Circuit Block Diagram

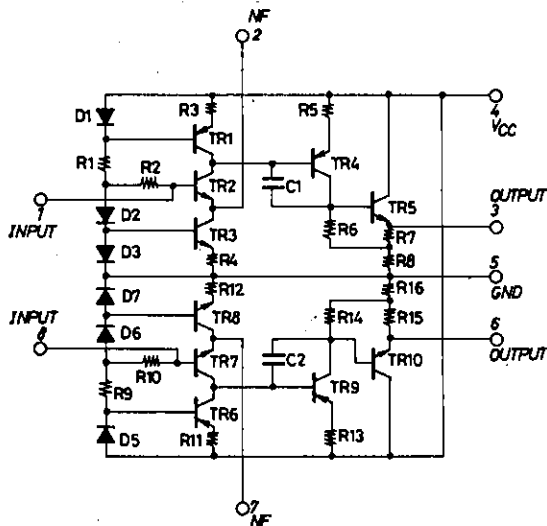

Package Dimensions 3016B
(unit: mm)

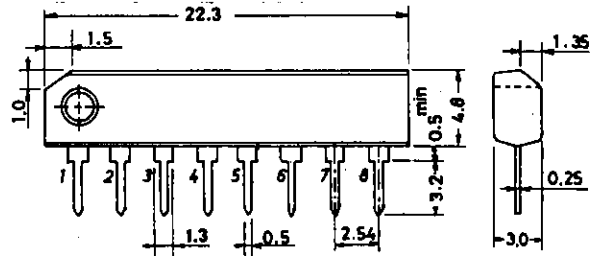

SANYO: SIP8

SANYO Electric Co., Ltd. Semiconductor Business Headquarters
TOKYO OFFICE Tokyo Bldg., 1-10, 1 Chome, Ueno, Taito-ku, TOKYO, 110 JAPAN

N0493TH/7160TS/O137KI/8044KI/8250KI, TS No.494-1/7

LA3160

Test Circuit 1 : V_O , V_G , THD, I_{CC} , r_i

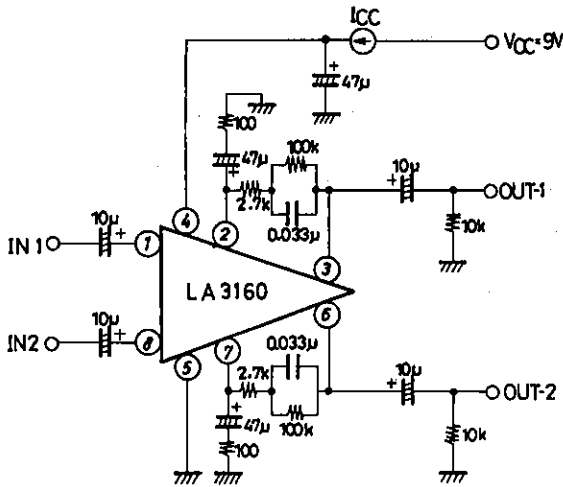

Test Circuit 2 : V_{G0}

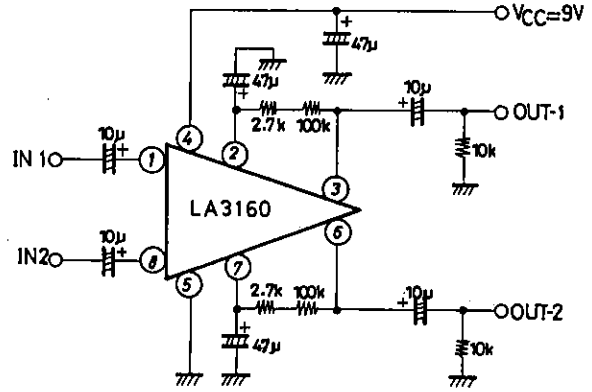

Unit (resistance: Ω , capacitance: F)

Test Circuit 3 : Noise

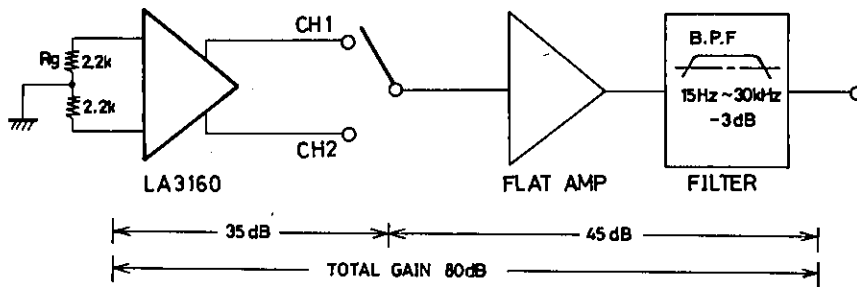

Sample Application Circuit 1 : Preamplifier for Car Stereo

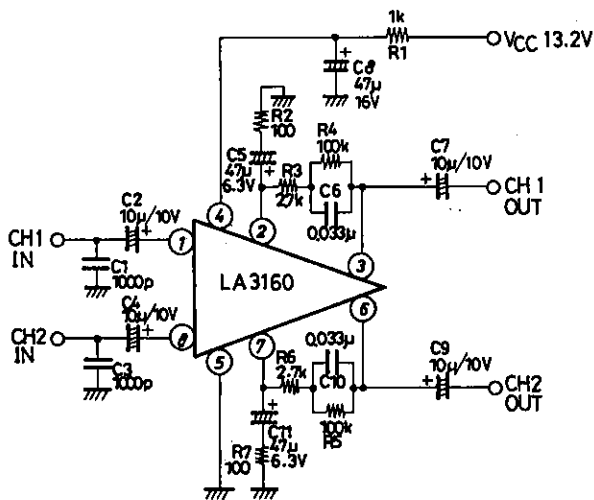

Unit (resistance: Ω , capacitance: F)

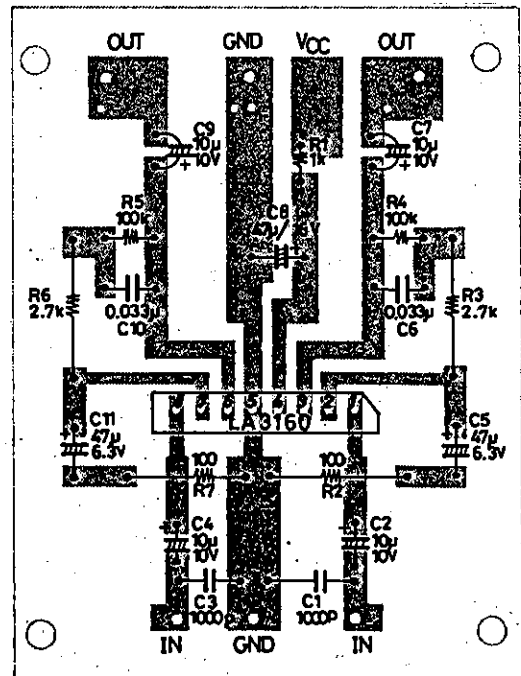

Sample Printed Circuit Pattern
(Cu-foiled area, $67 \times 50\text{mm}^2$)

LA3160

Function of External Parts

C₂, C₄ are input coupling capacitors. In NAB equalizer amplifier, the gain at low frequencies is high and 1/f noise inside the IC is emphasized as output noise. Therefore, if the reactance of capacitor at low frequencies is increased, the dependence of 1/f noise on the signal source resistance causes the output noise voltage to deteriorate, and the value of reactance must be made small enough as compared with the signal source resistance. C₂, C₄ also influence the operation start time and the adequate value of these capacitors is 10uF. (Since C₂, C₄ of less than 4.7uF make the operation start time longer, use C₂, C₄ of 4.7uF or more.)

C₅, C₁₁ are NF capacitors. The lower cut-off frequency depends on the value of these capacitors.

If the lower cut-off frequency is taken as f_L :

$$C5 (C11) = 1/2\pi \cdot f_L \cdot R2 (R7)$$

If the value of this capacitor is made larger, the operation start time of amplifier is more delayed. The adequate value of capacitor is 47uF.

The frequency characteristic of the equalizer amplifier depends on C₆ and R₄, R₃ (C₁₀ and R₅, R₆).

The time constants to obtain the standard NAB characteristic are as shown below.

Tape speed	9.5 cm/sec	4.75 cm/sec
C6 (R3+R4)	3180 μ sec	1590 μ sec
R3 C6	90 μ sec	120 μ sec

C₈ is a bias capacitor for the power line. C₈ of 47uF is inserted at a point as close to the power supply pin (pin 4) as possible.

C₁, C₃ are for preventing radio interference in the strong electric field, interference attributable to engine noise, and blocking oscillation at the time of large amplitude operation. The adequate value of C₁, C₃ is approximately 1000pF.

C₇, C₉ are output coupling capacitors. The adequate value of C₇, C₉ is 10uF.

NAB element and determination of gain

Since the DC feedback is provided by R₁, R₂ of NAB element, which brings about DC output potential at pins 3, 6, it is impossible to change the value of R₁, R₂ of NAB element greatly. Therefore, when determining the gain, change R_{NF} with R₁, R₂, C₁ (NAB element) kept constant.

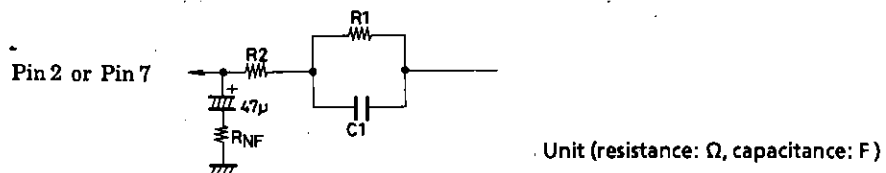

- (1) How to obtain R_{NF}
Impedance Z of NAB element is

$$Z = \frac{1}{1/R1 + j\omega C1} + R2$$

$$= (R1 + R2) \left\{ \frac{1 + j\omega C1 \left(\frac{R1 R2}{R1 + R2} \right)}{1 + j\omega C1 R1} \right\}$$

For a general negative feedback amplifier circuit, A=A_o/(1+A_oβ) applies, and Z=A·R_{NF} is obtained under conditions of A_o ≫ A, A ≫ 1 (β=R_{NF}/(R_{NF}+Z), A_o=open-loop gain, A=feedback gain).

Therefore, we can use an approximation of R_{NF}=Z/A.

A = (VG for 1 kHz) times, (Set R₁, R₂ at approximately 100kohms.)

Each time constant of NAB characteristic

Tape speed	9.5 cm/sec	4.75 cm/sec
T1 C1, R1	3180 μ sec	1590 μ sec
T2 C1 (R1//R2)	90 μ sec	120 μ sec

LA3160

Unit (resistance: Ω , capacitance: F)

(2) Examples of NAB Constants

(a) Tape speed : 9.5cm/sec for an 8-track recorder (Z, AG at $f=1kHz$)

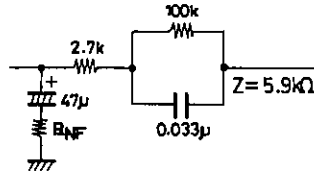

VG	30	35	40	dB
R _{NF}	180	100	56	ohm

(b) Tape speed : 4.75cm/sec for a cassette tape recorder

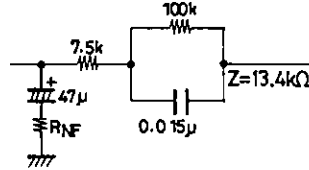

VG	30	35	40	dB
R _{NF}	440	240	130	ohm

(c) Flat amplifier

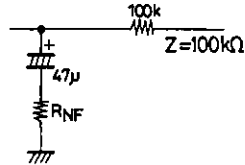

VG	30	35	40	dB
R _{NF}	3.2k	1.8k	1k	ohm

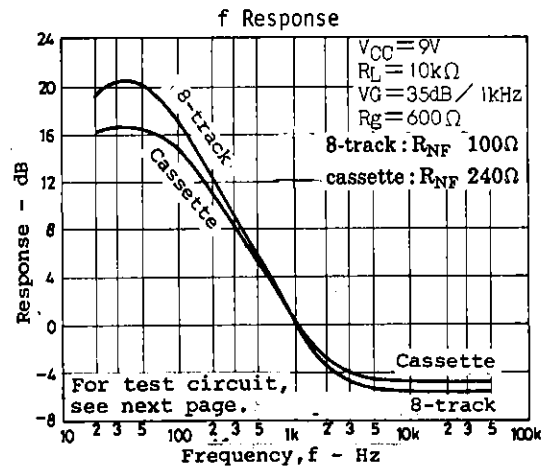
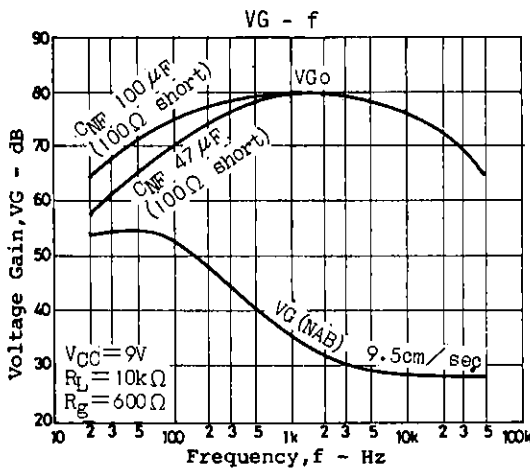
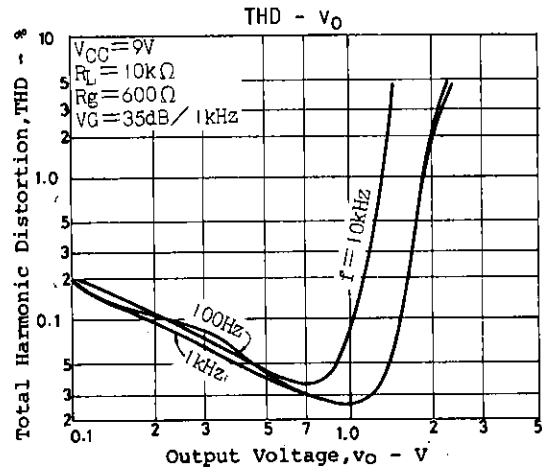
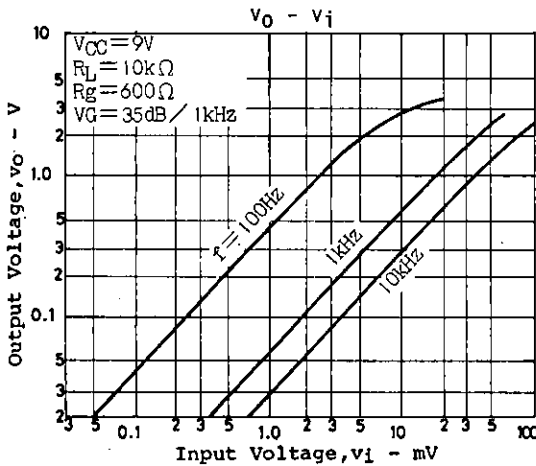

LA3160

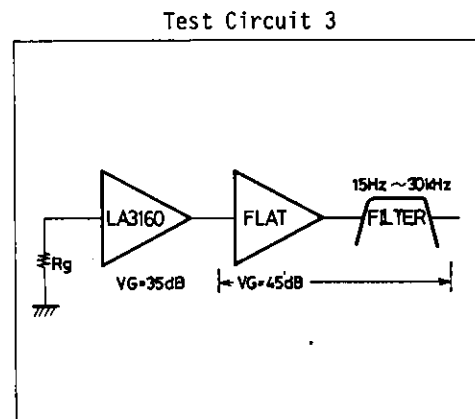
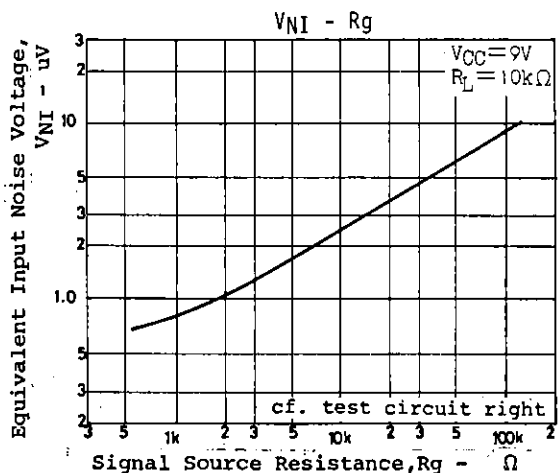
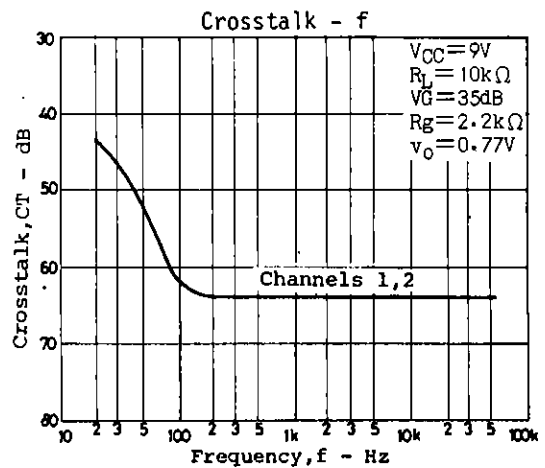
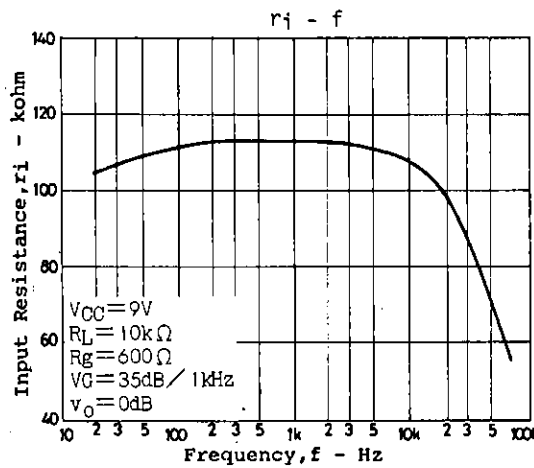
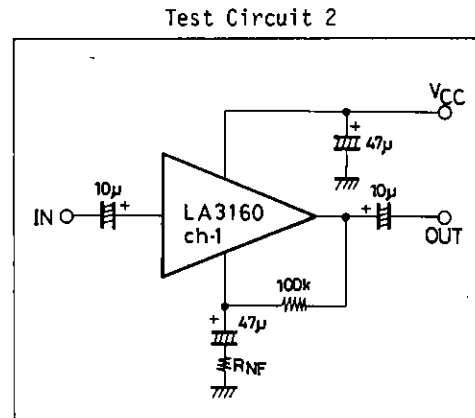
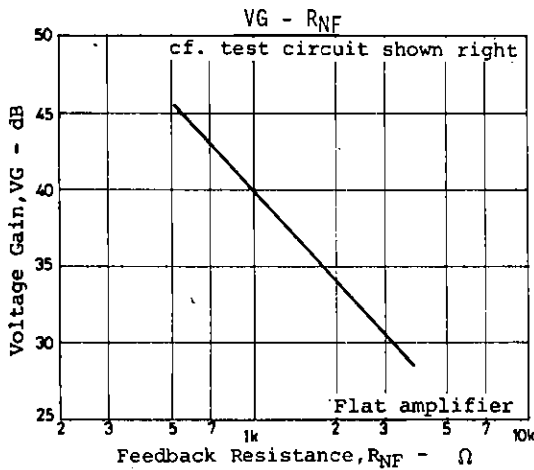
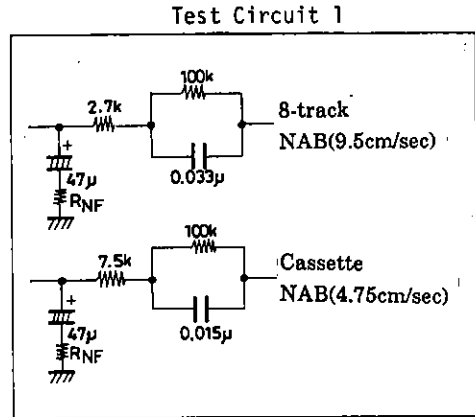
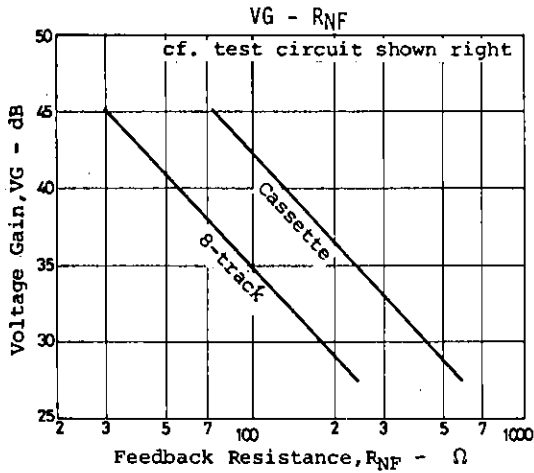

Unit (resistance: Ω, capacitance: F)

LA3160

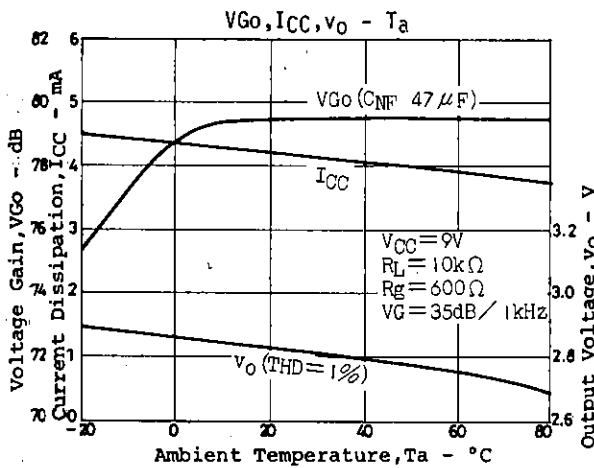
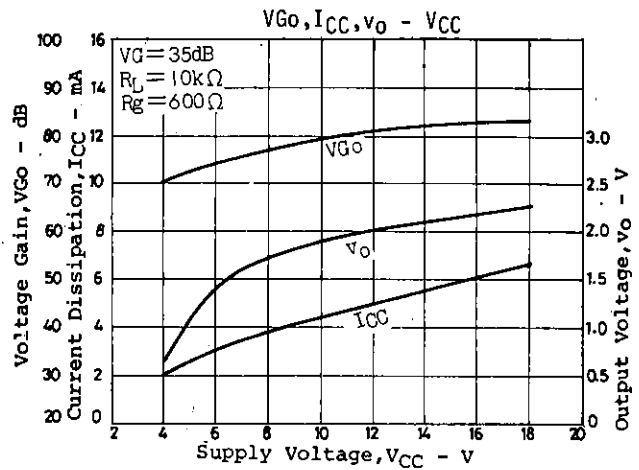
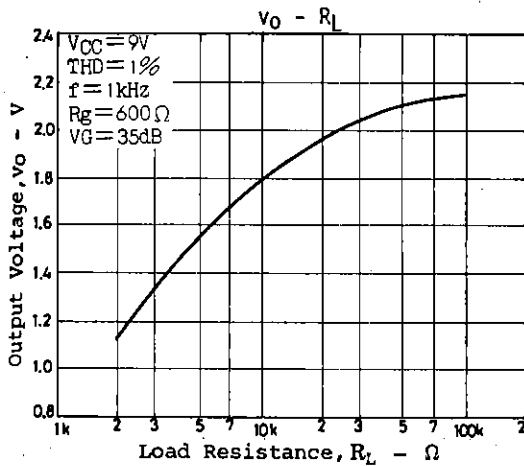

Proper cares in using IC

1. Maximum Rating

If the IC is used in the vicinity of the maximum rating, even a slight variation in conditions may cause the maximum rating to be exceeded, thereby leading to a breakdown. Allow an ample margin of variation for supply voltage, etc. and use the IC in the range where the maximum rating is not exceeded.

2. Short between pins

If the supply voltage is applied when the space between pins is shorted, a breakdown or deterioration may occur. When installing the IC on the board or applying the supply voltage, make sure that the space between pins is not shorted with solder, etc.

3. Breakdown of IC attributable to inverted insertion

If the IC is inserted inversely and operated, the IC may suffer from something unusual, thereby leading to a breakdown or deterioration of the IC. When installing the IC on the board or operating the IC, check the marked surface of IC.

Proper cares to be taken for obtaining optimum operation of IC

- Set DC resistance of R_1, R_2 of NAB element at approximately 100kohms.
- Determine the gain by changing R_{NF} without changing NAB constant. (Refer to Examples of NAB constant.)
- Supply voltage characteristics are sufficiently considered, but supply voltage is recommended to be between 5V to 18V.

LA3160

- No products described or contained herein are intended for use in surgical implants, life-support systems, aerospace equipment, nuclear power control systems, vehicles, disaster/crime-prevention equipment and the like, the failure of which may directly or indirectly cause injury, death or property loss.
- Anyone purchasing any products described or contained herein for an above-mentioned use shall:
 - ① Accept full responsibility and indemnify and defend SANYO ELECTRIC CO., LTD., its affiliates, subsidiaries and distributors and all their officers and employees, jointly and severally, against any and all claims and litigation and all damages, cost and expenses associated with such use:
 - ② Not impose any responsibility for any fault or negligence which may be cited in any such claim or litigation on SANYO ELECTRIC CO., LTD., its affiliates, subsidiaries and distributors or any of their officers and employees jointly or severally.
- Information (including circuit diagrams and circuit parameters) herein is for example only; it is not guaranteed for volume production. SANYO believes information herein is accurate and reliable, but no guarantees are made or implied regarding its use or any infringements of intellectual property rights or other rights of third parties.