

LM1577/LM2577 SIMPLE SWITCHER® Step-Up Voltage Regulator

 Check for Samples: [LM1577](#), [LM2577](#)

FEATURES

- Requires Few External Components
- NPN Output Switches 3.0A, can Stand off 65V
- Wide Input Voltage Range: 3.5V to 40V
- Current-mode Operation for Improved Transient Response, Line Regulation, and Current Limit
- 52 kHz Internal Oscillator
- Soft-start Function Reduces In-rush Current During Start-up
- Output Switch Protected by Current Limit, Under-voltage Lockout, and Thermal Shutdown

TYPICAL APPLICATIONS

- Simple Boost Regulator
- Flyback and Forward Regulators
- Multiple-output Regulator

DESCRIPTION

The LM1577/LM2577 are monolithic integrated circuits that provide all of the power and control functions for step-up (boost), flyback, and forward converter switching regulators. The device is available in three different output voltage versions: 12V, 15V, and adjustable.

Requiring a minimum number of external components, these regulators are cost effective, and simple to use. Listed in this data sheet are a family of standard inductors and flyback transformers designed to work with these switching regulators.

Included on the chip is a 3.0A NPN switch and its associated protection circuitry, consisting of current and thermal limiting, and undervoltage lockout. Other features include a 52 kHz fixed-frequency oscillator that requires no external components, a soft start mode to reduce in-rush current during start-up, and current mode control for improved rejection of input voltage and output load transients.

Connection Diagrams

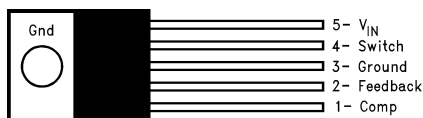

Figure 1. 5-Lead (Straight Leads) TO-220 (T) – Top View
See Package Number KC

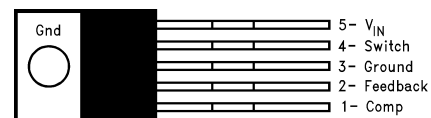
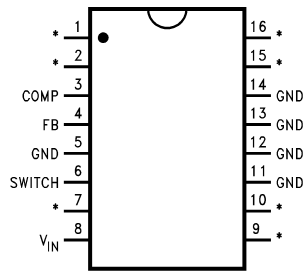
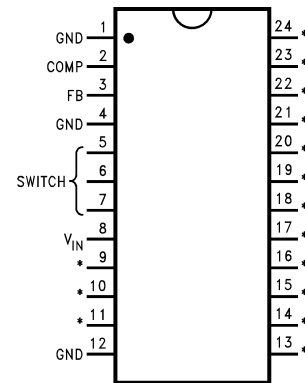

Figure 2. 5-Lead (Bent, Staggered Leads) TO-220 (T) – Top View
See Package Number NDH0005D



*No Internal Connection

Figure 3. 16-Lead PDIP (N) – Top View
See Package Number NBG0016G



*No internal Connection

Figure 4. 24-Lead SOIC Package (M) – Top View
See Package Number DW

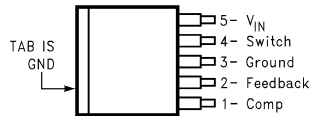

Figure 5. 5-Lead DDPak/TO-263 (S) SFM Package – Top View
See Package Number KTT0005B

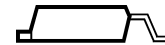

Figure 6. 5-Lead DDPak/TO-263 (S) SFM Package – Side View

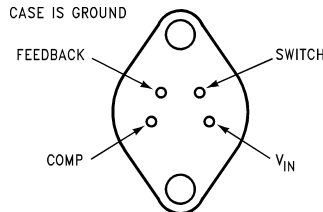
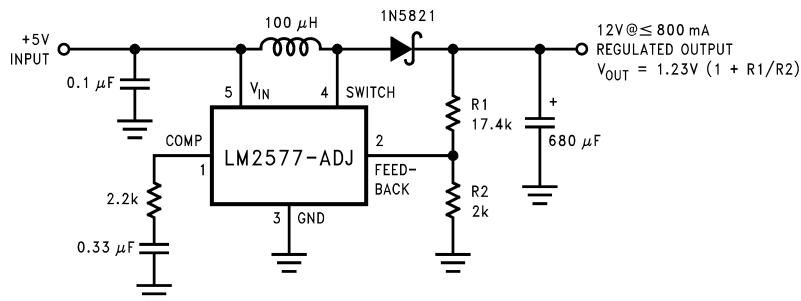

Figure 7. 4-Lead TO-220 (K) – Bottom View
See Package Number NEB0005B

Typical Application



Note: Pin numbers shown are for TO-220 (T) package.



These devices have limited built-in ESD protection. The leads should be shorted together or the device placed in conductive foam during storage or handling to prevent electrostatic damage to the MOS gates.

Absolute Maximum Ratings⁽¹⁾⁽²⁾

Supply Voltage		45V
Output Switch Voltage		65V
Output Switch Current ⁽³⁾		6.0A
Power Dissipation		Internally Limited
Storage Temperature Range		-65°C to +150°C
Lead Temperature	Soldering, 10 sec.	260°C
Maximum Junction Temperature		150°C
Minimum ESD Rating	C = 100 pF, R = 1.5 kΩ	2 kV

- (1) Absolute Maximum Ratings indicate limits beyond which damage to the device may occur. Operating ratings indicate conditions the device is intended to be functional, but device parameter specifications may not be ensured under these conditions. For ensured specifications and test conditions, see the Electrical Characteristics.
- (2) If Military/Aerospace specified devices are required, please contact the Texas Instruments Sales Office/ Distributors for availability and specifications.
- (3) Due to timing considerations of the LM1577/LM2577 current limit circuit, output current cannot be internally limited when the LM1577/LM2577 is used as a step-up regulator. To prevent damage to the switch, its current must be externally limited to 6.0A. However, output current is internally limited when the LM1577/LM2577 is used as a flyback or forward converter regulator in accordance to the Application Hints.

Operating Ratings

Supply Voltage		$3.5V \leq V_{IN} \leq 40V$
Output Switch Voltage		$0V \leq V_{SWITCH} \leq 60V$
Output Switch Current		$I_{SWITCH} \leq 3.0A$
Junction Temperature Range	LM1577	$-55^\circ C \leq T_J \leq +150^\circ C$
	LM2577	$-40^\circ C \leq T_J \leq +125^\circ C$

Electrical Characteristics—LM1577-12, LM2577-12

Specifications with standard type face are for $T_J = 25^\circ C$, and those in **bold type face** apply over full **Operating Temperature Range**. Unless otherwise specified, $V_{IN} = 5V$, and $I_{SWITCH} = 0$.

Symbol	Parameter	Conditions	Typical	LM1577-12 Limit ⁽¹⁾⁽²⁾	LM2577-12 Limit ⁽³⁾	Units (Limits)
SYSTEM PARAMETERS Circuit of Figure 29 ⁽⁴⁾						
V_{OUT}	Output Voltage	$V_{IN} = 5V$ to 10V $I_{LOAD} = 100$ mA to 800 mA ⁽¹⁾	12.0			V
				11.60/11.40	11.60/11.40	V(min)
				12.40/12.60	12.40/12.60	V(max)
$\frac{\Delta V_{OUT}}{\Delta V_{IN}}$ (1)	Line Regulation	$V_{IN} = 3.5V$ to 10V $I_{LOAD} = 300$ mA	20			mV
				50/100	50/100	mV(max)
$\frac{\Delta V_{OUT}}{\Delta I_{LOAD}}$ (2)	Load Regulation	$V_{IN} = 5V$ $I_{LOAD} = 100$ mA to 800 mA	20			mV
				50/100	50/100	mV(max)
η	Efficiency	$V_{IN} = 5V$, $I_{LOAD} = 800$ mA	80			%
DEVICE PARAMETERS						
I_S	Input Supply Current	$V_{FEEDBACK} = 14V$ (Switch Off)	7.5			mA
				10.0/14.0	10.0/14.0	mA(max)
		$I_{SWITCH} = 2.0A$ $V_{COMP} = 2.0V$ (Max Duty Cycle)	25			mA
				50/85	50/85	mA(max)

- (1) All limits ensured at room temperature (standard type face) and at temperature extremes (boldface type). All limits are used to calculate Outgoing Quality Level, and are 100% production tested.
- (2) A military RETS electrical test specification is available on request. At the time of printing, the LM1577K-12/883, LM1577K-15/883, and LM1577K-ADJ/883 RETS specifications complied fully with the boldface limits in these columns. The LM1577K-12/883, LM1577K-15/883, and LM1577K-ADJ/883 may also be procured to Standard Military Drawing specifications.
- (3) All limits ensured at room temperature (standard type face) and at temperature extremes (boldface type). All room temperature limits are 100% production tested. All limits at temperature extremes are ensured via correlation using standard Statistical Quality Control (SQC) methods.
- (4) External components such as the diode, inductor, input and output capacitors can affect switching regulator performance. When the LM1577/LM2577 is used as shown in the Test Circuit, system performance will be as specified by the system parameters.

Electrical Characteristics—LM1577-12, LM2577-12 (continued)

Specifications with standard type face are for $T_J = 25^\circ\text{C}$, and those in **bold type face** apply over full **Operating Temperature Range**. Unless otherwise specified, $V_{IN} = 5\text{V}$, and $I_{\text{SWITCH}} = 0$.

Symbol	Parameter	Conditions	Typical	LM1577-12 Limit ⁽¹⁾⁽²⁾	LM2577-12 Limit ⁽³⁾	Units (Limits)
V_{UV}	Input Supply Undervoltage Lockout	$I_{\text{SWITCH}} = 100\text{ mA}$	2.90			V
				2.70/ 2.65	2.70/ 2.65	V(min)
				3.10/ 3.15	3.10/ 3.15	V(max)
f_O	Oscillator Frequency	Measured at Switch Pin $I_{\text{SWITCH}} = 100\text{ mA}$	52			kHz
				48/42	48/42	kHz(min)
				56/62	56/62	kHz(max)
V_{REF}	Output Reference Voltage	Measured at Feedback Pin $V_{IN} = 3.5\text{V to }40\text{V}$ $V_{COMP} = 1.0\text{V}$				V
			12	11.76/ 11.64	11.76/ 11.64	V(min)
				12.24/ 12.36	12.24/ 12.36	V(max)
$\frac{\Delta V_{REF}}{\Delta V_{IN}}$	Output Reference Voltage Line Regulator	$V_{IN} = 3.5\text{V to }40\text{V}$	7			mV
R_{FB}	Feedback Pin Input Resistance		9.7			k Ω
G_M	Error Amp Transconductance	$I_{COMP} = -30\ \mu\text{A to }+30\ \mu\text{A}$ $V_{COMP} = 1.0\text{V}$	370			μmho
				225/ 145	225/ 145	$\mu\text{mho(min)}$
				515/ 615	515/ 615	$\mu\text{mho(max)}$
A_{VOL}	Error Amp Voltage Gain	$V_{COMP} = 1.1\text{V to }1.9\text{V}$ $R_{COMP} = 1.0\text{ M}\Omega^{(5)}$	80			V/V
				50/ 25	50/ 25	V/V(min)
	Error Amplifier Output Swing	Upper Limit $V_{FEEDBACK} = 10.0\text{V}$	2.4			V
			2.2/ 2.0	2.2/ 2.0	V(min)	
		Lower Limit $V_{FEEDBACK} = 15.0\text{V}$	0.3			V
			0.40/ 0.55	0.40/ 0.55	V(max)	
	Error Amplifier Output Current	$V_{FEEDBACK} = 10.0\text{V to }15.0\text{V}$ $V_{COMP} = 1.0\text{V}$	± 200			μA
				± 130 / ± 90	± 130 / ± 90	$\mu\text{A(min)}$
				± 300 / ± 400	± 300 / ± 400	$\mu\text{A(max)}$
I_{SS}	Soft Start Current	$V_{FEEDBACK} = 10.0\text{V}$ $V_{COMP} = 0\text{V}$	5.0			μA
				2.5/ 1.5	2.5/ 1.5	$\mu\text{A(min)}$
				7.5/ 9.5	7.5/ 9.5	$\mu\text{A(max)}$
D	Maximum Duty Cycle	$V_{COMP} = 1.5\text{V}$ $I_{\text{SWITCH}} = 100\text{ mA}$	95			%
				93/ 90	93/ 90	%(min)
$\frac{\Delta I_{\text{SWITCH}}}{\Delta V_{COMP}}$	Switch Transconductance		12.5			A/V
I_L	Switch Leakage Current	$V_{\text{SWITCH}} = 65\text{V}$ $V_{FEEDBACK} = 15\text{V (Switch Off)}$	10			μA
				300/ 600	300/ 600	$\mu\text{A(max)}$
V_{SAT}	Switch Saturation Voltage	$I_{\text{SWITCH}} = 2.0\text{A}$ $V_{COMP} = 2.0\text{V (Max Duty Cycle)}$	0.5			V
				0.7/ 0.9	0.7/ 0.9	V(max)
	NPN Switch Current Limit		4.5			A
				3.7/ 3.0	3.7/ 3.0	A(min)
				5.3/ 6.0	5.3/ 6.0	A(max)

(5) A 1.0 M Ω resistor is connected to the compensation pin (which is the error amplifier's output) to ensure accuracy in measuring A_{VOL} . In actual applications, this pin's load resistance should be $\geq 10\text{ M}\Omega$, resulting in A_{VOL} that is typically twice the ensured minimum limit.

Electrical Characteristics—LM1577-15, LM2577-15

 Specifications with standard type face are for $T_J = 25^\circ\text{C}$, and those in **bold type face** apply over full **Operating Temperature Range**. Unless otherwise specified, $V_{IN} = 5\text{V}$, and $I_{SWITCH} = 0$.

Symbol	Parameter	Conditions	Typical	LM1577-15 Limit ⁽¹⁾⁽²⁾	LM2577-15 Limit ⁽³⁾	Units (Limits)
SYSTEM PARAMETERS Circuit of Figure 30 ⁽⁴⁾						
V_{OUT}	Output Voltage	$V_{IN} = 5\text{V to }12\text{V}$ $I_{LOAD} = 100\text{ mA to }600\text{ mA}$ (1)	15.0			V
				14.50/ 14.25	14.50/ 14.25	V(min)
				15.50/ 15.75	15.50/ 15.75	V(max)
$\frac{\Delta V_{OUT}}{\Delta V_{IN}}$	Line Regulation	$V_{IN} = 3.5\text{V to }12\text{V}$ $I_{LOAD} = 300\text{ mA}$	20	50/ 100	50/ 100	mV mV(max)
$\frac{\Delta V_{OUT}}{\Delta I_{LOAD}}$	Load Regulation	$V_{IN} = 5\text{V}$ $I_{LOAD} = 100\text{ mA to }600\text{ mA}$	20	50/ 100	50/ 100	mV mV(max)
η	Efficiency	$V_{IN} = 5\text{V}$, $I_{LOAD} = 600\text{ mA}$	80			%
DEVICE PARAMETERS						
I_S	Input Supply Current	$V_{FEEDBACK} = 18.0\text{V}$ (Switch Off)	7.5			mA
				10.0/ 14.0	10.0/ 14.0	mA(max)
			25			mA
		$I_{SWITCH} = 2.0\text{A}$ $V_{COMP} = 2.0\text{V}$ (Max Duty Cycle)		50/ 85	50/ 85	mA(max)
V_{UV}	Input Supply Undervoltage Lockout	$I_{SWITCH} = 100\text{ mA}$	2.90			V
				2.70/ 2.65	2.70/ 2.65	V(min)
				3.10/ 3.15	3.10/ 3.15	V(max)
f_O	Oscillator Frequency	Measured at Switch Pin $I_{SWITCH} = 100\text{ mA}$	52			kHz
				48/ 42	48/ 42	kHz(min)
				56/ 62	56/ 62	kHz(max)
V_{REF}	Output Reference Voltage	Measured at Feedback Pin $V_{IN} = 3.5\text{V to }40\text{V}$ $V_{COMP} = 1.0\text{V}$				V
			15	14.70/ 14.55	14.70/ 14.55	V(min)
				15.30/ 15.45	15.30/ 15.45	V(max)
$\frac{\Delta V_{REF}}{\Delta V_{IN}}$	Output Reference Voltage Line Regulation	$V_{IN} = 3.5\text{V to }40\text{V}$	10			mV
R_{FB}	Feedback Pin Input Voltage Line Regulator		12.2			k Ω
G_M	Error Amp Transconductance	$I_{COMP} = -30\ \mu\text{A to }+30\ \mu\text{A}$ $V_{COMP} = 1.0\text{V}$	300			μmho
				170/ 110	170/ 110	$\mu\text{mho(min)}$
				420/ 500	420/ 500	$\mu\text{mho(max)}$
A_{VOL}	Error Amp Voltage Gain	$V_{COMP} = 1.1\text{V to }1.9\text{V}$ $R_{COMP} = 1.0\ \text{M}\Omega$ ⁽⁵⁾	65			V/V
				40/ 20	40/ 20	V/V(min)

- (1) All limits ensured at room temperature (standard type face) and at temperature extremes (boldface type). All limits are used to calculate Outgoing Quality Level, and are 100% production tested.
- (2) A military RETS electrical test specification is available on request. At the time of printing, the LM1577K-12/883, LM1577K-15/883, and LM1577K-ADJ/883 RETS specifications complied fully with the boldface limits in these columns. The LM1577K-12/883, LM1577K-15/883, and LM1577K-ADJ/883 may also be procured to Standard Military Drawing specifications.
- (3) All limits ensured at room temperature (standard type face) and at temperature extremes (boldface type). All room temperature limits are 100% production tested. All limits at temperature extremes are ensured via correlation using standard Statistical Quality Control (SQC) methods.
- (4) External components such as the diode, inductor, input and output capacitors can affect switching regulator performance. When the LM1577/LM2577 is used as shown in the Test Circuit, system performance will be as specified by the system parameters.
- (5) A 1.0 M Ω resistor is connected to the compensation pin (which is the error amplifier's output) to ensure accuracy in measuring A_{VOL} . In actual applications, this pin's load resistance should be $\geq 10\ \text{M}\Omega$, resulting in A_{VOL} that is typically twice the ensured minimum limit.

Electrical Characteristics—LM1577-15, LM2577-15 (continued)

Specifications with standard type face are for $T_J = 25^\circ\text{C}$, and those in **bold type face** apply over full **Operating Temperature Range**. Unless otherwise specified, $V_{IN} = 5\text{V}$, and $I_{\text{SWITCH}} = 0$.

Symbol	Parameter	Conditions	Typical	LM1577-15 Limit ⁽¹⁾⁽²⁾	LM2577-15 Limit ⁽³⁾	Units (Limits)
	Error Amplifier Output Swing	Upper Limit $V_{\text{FEEDBACK}} = 12.0\text{V}$	2.4			V
				2.2/2.0	2.2/2.0	V(min)
		Lower Limit $V_{\text{FEEDBACK}} = 18.0\text{V}$	0.3			V
				0.4/0.55	0.40/0.55	V(max)
	Error Amp Output Current	$V_{\text{FEEDBACK}} = 12.0\text{V}$ to 18.0V $V_{\text{COMP}} = 1.0\text{V}$	± 200			μA
				$\pm 130/\pm 90$	$\pm 130/\pm 90$	$\mu\text{A}(\text{min})$
				$\pm 300/\pm 400$	$\pm 300/\pm 400$	$\mu\text{A}(\text{max})$
I_{SS}	Soft Start Current	$V_{\text{FEEDBACK}} = 12.0\text{V}$ $V_{\text{COMP}} = 0\text{V}$	5.0			μA
				2.5/1.5	2.5/1.5	$\mu\text{A}(\text{min})$
				7.5/9.5	7.5/9.5	$\mu\text{A}(\text{max})$
D	Maximum Duty Cycle	$V_{\text{COMP}} = 1.5\text{V}$ $I_{\text{SWITCH}} = 100\text{ mA}$	95			%
				93/90	93/90	% (min)
$\frac{\Delta I_{\text{SWITCH}}}{\Delta V_{\text{COMP}}}$	Switch Transconductance		12.5			A/V
I_{L}	Switch Leakage Current	$V_{\text{SWITCH}} = 65\text{V}$ $V_{\text{FEEDBACK}} = 18.0\text{V}$ (Switch Off)	10			μA
				300/600	300/600	$\mu\text{A}(\text{max})$
V_{SAT}	Switch Saturation Voltage	$I_{\text{SWITCH}} = 2.0\text{A}$ $V_{\text{COMP}} = 2.0\text{V}$ (Max Duty Cycle)	0.5			V
				0.7/0.9	0.7/0.9	V(max)
	NPN Switch Current Limit	$V_{\text{COMP}} = 2.0\text{V}$	4.3			A
				3.7/3.0	3.7/3.0	A(min)
				5.3/6.0	5.3/6.0	A(max)

Electrical Characteristics—LM1577-ADJ, LM2577-ADJ

 Specifications with standard type face are for $T_J = 25^\circ\text{C}$, and those in **bold type face** apply over full **Operating Temperature Range**. Unless otherwise specified, $V_{IN} = 5\text{V}$, $V_{FEEDBACK} = V_{REF}$, and $I_{SWITCH} = 0$.

Symbol	Parameter	Conditions	Typical	LM1577-ADJ Limit ⁽¹⁾⁽²⁾	LM2577-ADJ Limit ⁽³⁾	Units (Limits)
SYSTEM PARAMETERS Circuit of Figure 31 ⁽⁴⁾						
V_{OUT}	Output Voltage	$V_{IN} = 5\text{V to }10\text{V}$ $I_{LOAD} = 100\text{ mA to }800\text{ mA}^{(1)}$	12.0			V
				11.60/ 11.40	11.60/ 11.40	V(min)
				12.40/ 12.60	12.40/ 12.60	V(max)
$\Delta V_{OUT}/\Delta V_{IN}$	Line Regulation	$V_{IN} = 3.5\text{V to }10\text{V}$ $I_{LOAD} = 300\text{ mA}$	20			mV
				50/ 100	50/ 100	mV(max)
$\Delta V_{OUT}/\Delta I_{LOAD}$	Load Regulation	$V_{IN} = 5\text{V}$ $I_{LOAD} = 100\text{ mA to }800\text{ mA}$	20			mV
				50/ 100	50/ 100	mV(max)
η	Efficiency	$V_{IN} = 5\text{V}$, $I_{LOAD} = 800\text{ mA}$	80			%
DEVICE PARAMETERS						
I_S	Input Supply Current	$V_{FEEDBACK} = 1.5\text{V}$ (Switch Off)	7.5			mA
				10.0/ 14.0	10.0/ 14.0	mA(max)
			$I_{SWITCH} = 2.0\text{A}$ $V_{COMP} = 2.0\text{V}$ (Max Duty Cycle)	25		
				50/ 85	50/ 85	mA(max)
V_{UV}	Input Supply Undervoltage Lockout	$I_{SWITCH} = 100\text{ mA}$	2.90			V
				2.70/ 2.65	2.70/ 2.65	V(min)
				3.10/ 3.15	3.10/ 3.15	V(max)
f_O	Oscillator Frequency	Measured at Switch Pin $I_{SWITCH} = 100\text{ mA}$	52			kHz
				48/ 42	48/ 42	kHz(min)
				56/ 62	56/ 62	kHz(max)
V_{REF}	Reference Voltage	Measured at Feedback Pin $V_{IN} = 3.5\text{V to }40\text{V}$ $V_{COMP} = 1.0\text{V}$	1.230	1.214/ 1.206	1.214/ 1.206	V
						V(min)
				1.246/ 1.254	1.246/ 1.254	V(max)
$\Delta V_{REF}/\Delta V_{IN}$	Reference Voltage Line Regulation	$V_{IN} = 3.5\text{V to }40\text{V}$	0.5			mV
I_B	Error Amp Input Bias Current	$V_{COMP} = 1.0\text{V}$	100			nA
				300/ 800	300/ 800	nA(max)
G_M	Error Amp Transconductance	$I_{COMP} = -30\text{ }\mu\text{A to }+30\text{ }\mu\text{A}$ $V_{COMP} = 1.0\text{V}$	3700			μmho
				2400/ 1600	2400/ 1600	μmho (min)
				4800/ 5800	4800/ 5800	μmho (max)
A_{VOL}	Error Amp Voltage Gain	$V_{COMP} = 1.1\text{V to }1.9\text{V}$ $R_{COMP} = 1.0\text{ M}\Omega^{(5)}$	800			V/V
				500/ 250	500/ 250	V/V(min)
	Error Amplifier Output Swing	Upper Limit $V_{FEEDBACK} = 1.0\text{V}$	2.4			V
				2.2/ 2.0	2.2/ 2.0	V(min)
		Lower Limit $V_{FEEDBACK} = 1.5\text{V}$	0.3			V
				0.40/ 0.55	0.40/ 0.55	V(max)

- (1) All limits ensured at room temperature (standard type face) and at temperature extremes (boldface type). All limits are used to calculate Outgoing Quality Level, and are 100% production tested.
- (2) A military RETS electrical test specification is available on request. At the time of printing, the LM1577K-12/883, LM1577K-15/883, and LM1577K-ADJ/883 RETS specifications complied fully with the boldface limits in these columns. The LM1577K-12/883, LM1577K-15/883, and LM1577K-ADJ/883 may also be procured to Standard Military Drawing specifications.
- (3) All limits ensured at room temperature (standard type face) and at temperature extremes (boldface type). All room temperature limits are 100% production tested. All limits at temperature extremes are ensured via correlation using standard Statistical Quality Control (SQC) methods.
- (4) External components such as the diode, inductor, input and output capacitors can affect switching regulator performance. When the LM1577/LM2577 is used as shown in the Test Circuit, system performance will be as specified by the system parameters.
- (5) A 1.0 M Ω resistor is connected to the compensation pin (which is the error amplifier's output) to ensure accuracy in measuring A_{VOL} . In actual applications, this pin's load resistance should be $\geq 10\text{ M}\Omega$, resulting in A_{VOL} that is typically twice the ensured minimum limit.

Electrical Characteristics—LM1577-ADJ, LM2577-ADJ (continued)

Specifications with standard type face are for $T_J = 25^\circ\text{C}$, and those in **bold type face** apply over full **Operating Temperature Range**. Unless otherwise specified, $V_{IN} = 5\text{V}$, $V_{FEEDBACK} = V_{REF}$, and $I_{SWITCH} = 0$.

Symbol	Parameter	Conditions	Typical	LM1577-ADJ Limit ⁽¹⁾⁽²⁾	LM2577-ADJ Limit ⁽³⁾	Units (Limits)
	Error Amp Output Current	$V_{FEEDBACK} = 1.0\text{V to }1.5\text{V}$ $V_{COMP} = 1.0\text{V}$	± 200			μA
				$\pm 130/\mathbf{\pm 90}$	$\pm 130/\mathbf{\pm 90}$	$\mu\text{A}(\text{min})$
				$\pm 300/\mathbf{\pm 400}$	$\pm 300/\mathbf{\pm 400}$	$\mu\text{A}(\text{max})$
I_{SS}	Soft Start Current	$V_{FEEDBACK} = 1.0\text{V}$ $V_{COMP} = 0\text{V}$	5.0			μA
				2.5/1.5	2.5/1.5	$\mu\text{A}(\text{min})$
				7.5/9.5	7.5/9.5	$\mu\text{A}(\text{max})$
D	Maximum Duty Cycle	$V_{COMP} = 1.5\text{V}$ $I_{SWITCH} = 100\text{ mA}$	95			%
				93/90	93/90	% (min)
$\Delta I_{SWITCH}/\Delta V_{COMP}$	Switch Transconductance		12.5			A/V
I_L	Switch Leakage Current	$V_{SWITCH} = 65\text{V}$ $V_{FEEDBACK} = 1.5\text{V}$ (Switch Off)	10			μA
				300/600	300/600	$\mu\text{A}(\text{max})$
V_{SAT}	Switch Saturation Voltage	$I_{SWITCH} = 2.0\text{A}$ $V_{COMP} = 2.0\text{V}$ (Max Duty Cycle)	0.5			V
				0.7/0.9	0.7/0.9	V (max)
	NPN Switch Current Limit	$V_{COMP} = 2.0\text{V}$	4.3			A
				3.7/3.0	3.7/3.0	A (min)
				5.3/6.0	5.3/6.0	A (max)
THERMAL PARAMETERS (All Versions)						
θ_{JA} θ_{JC}	Thermal Resistance	K Package, Junction to Ambient	35			$^\circ\text{C/W}$
		K Package, Junction to Case	1.5			
θ_{JA} θ_{JC}		T Package, Junction to Ambient	65			
		T Package, Junction to Case	2			
θ_{JA}		N Package, Junction to Ambient ⁽⁶⁾	85			
θ_{JA}		M Package, Junction to Ambient ⁽⁶⁾	100			
θ_{JA}	S Package, Junction to Ambient ⁽⁷⁾	37				

(6) Junction to ambient thermal resistance with approximately 1 square inch of pc board copper surrounding the leads. Additional copper area will lower thermal resistance further. See thermal model in "Switchers Made Simple" software.

(7) If the DDPAK/TO-263 package is used, the thermal resistance can be reduced by increasing the PC board copper area thermally connected to the package. Using 0.5 square inches of copper area, θ_{JA} is 50°C/W ; with 1 square inch of copper area, θ_{JA} is 37°C/W ; and with 1.6 or more square inches of copper area, θ_{JA} is 32°C/W .

Typical Performance Characteristics

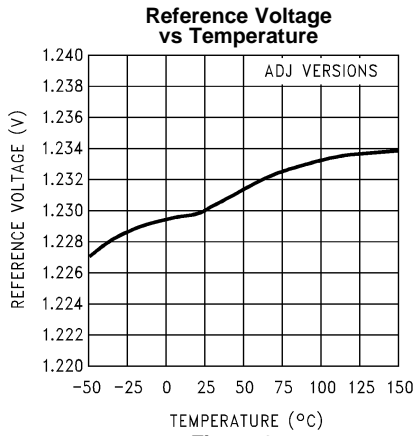

Figure 8.

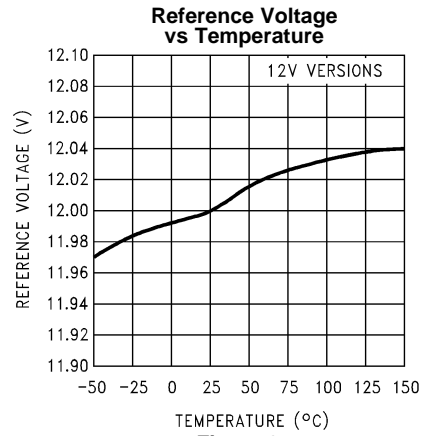

Figure 9.

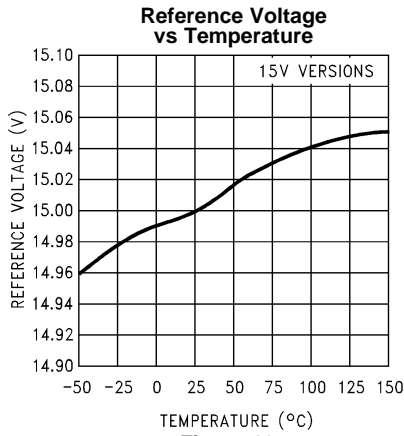

Figure 10.

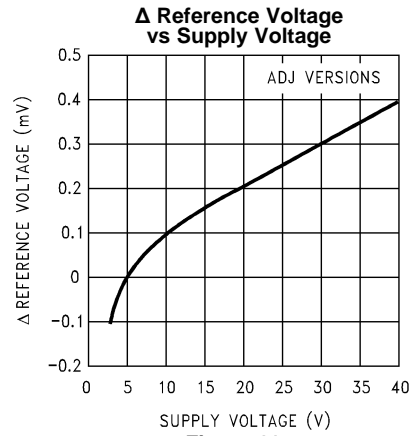

Figure 11.

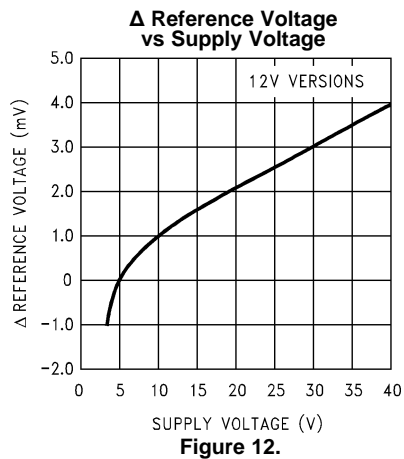

Figure 12.

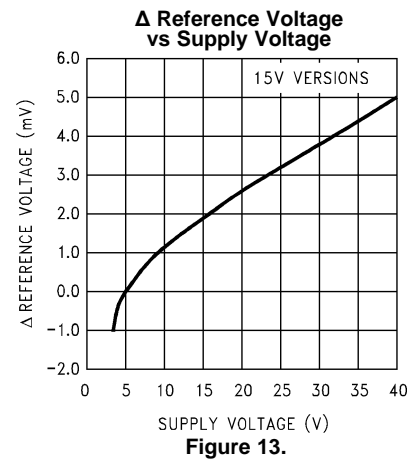

Figure 13.

Typical Performance Characteristics (continued)

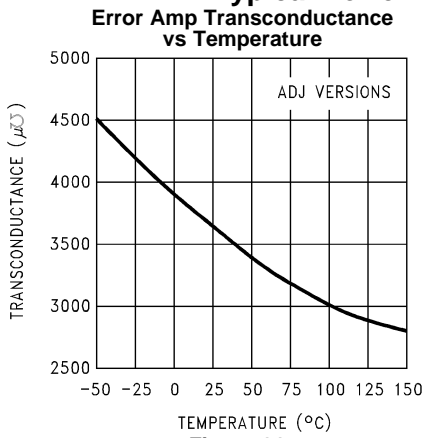

Figure 14.

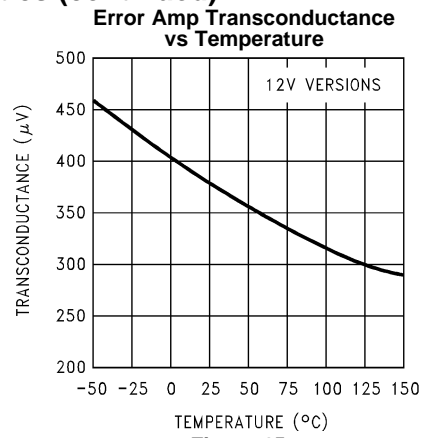

Figure 15.

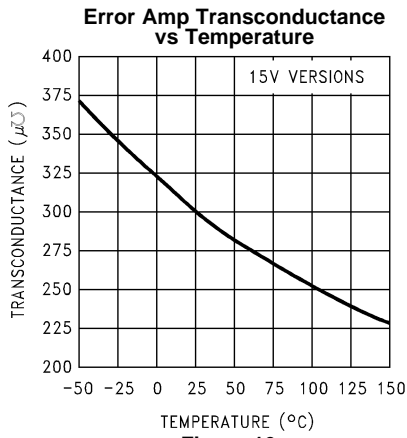

Figure 16.

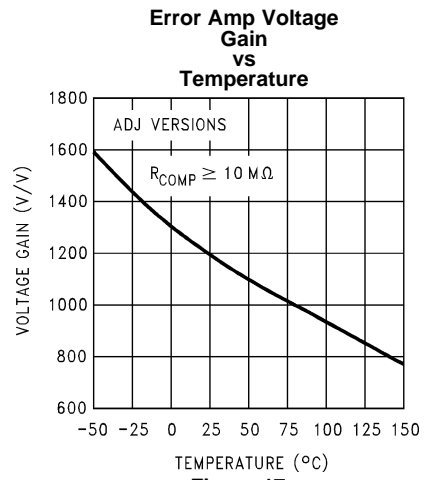

Figure 17.

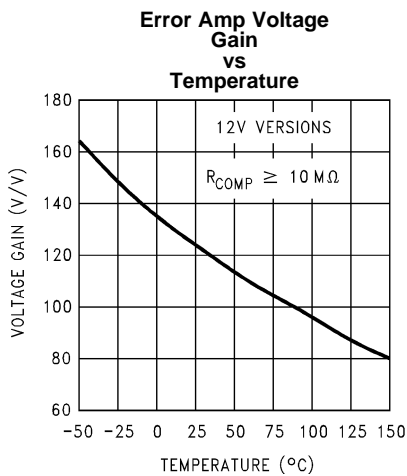

Figure 18.

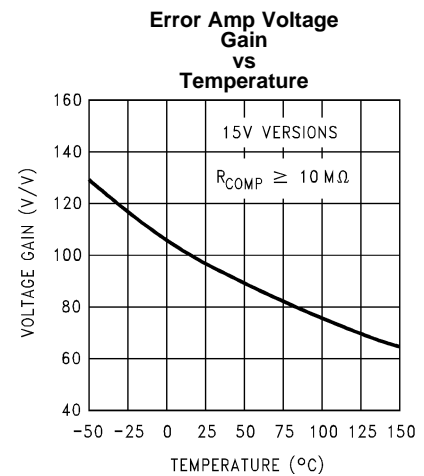
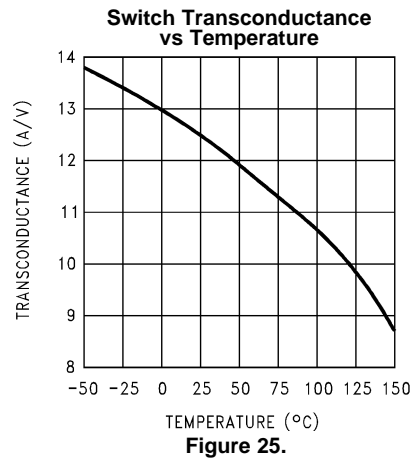
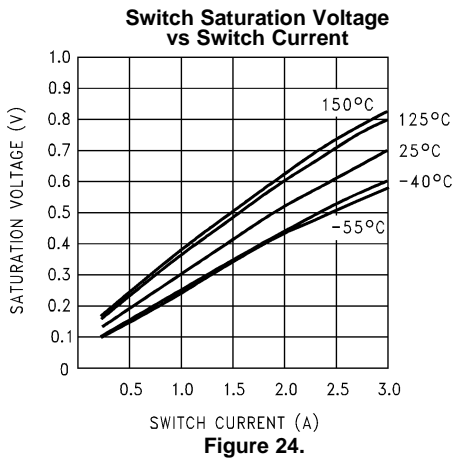
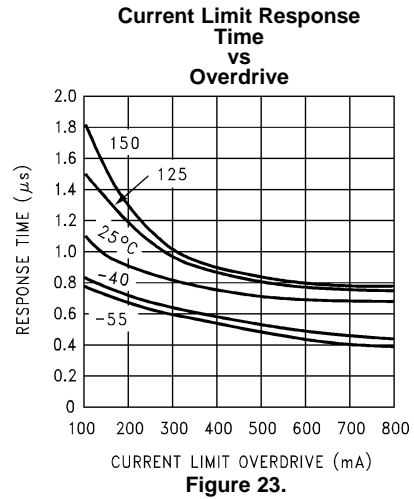
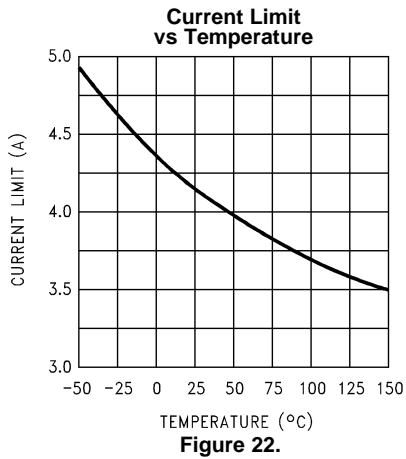
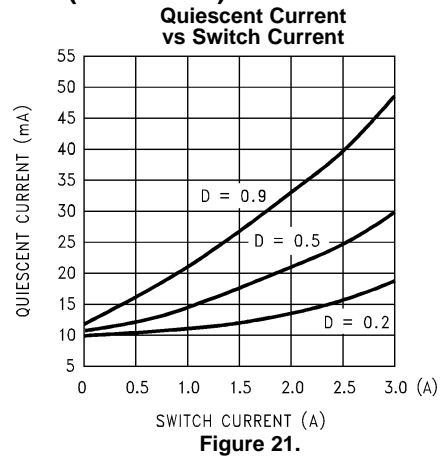
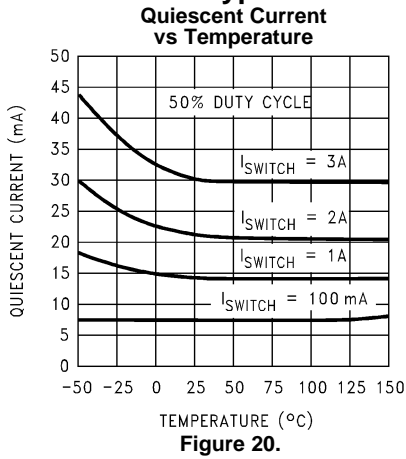

Figure 19.

Typical Performance Characteristics (continued)



Typical Performance Characteristics (continued)

Feedback Pin Bias Current vs Temperature

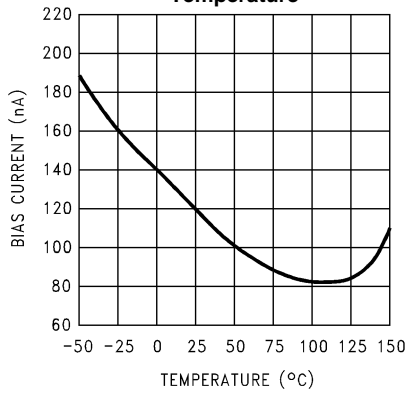

Figure 26.

Oscillator Frequency vs Temperature

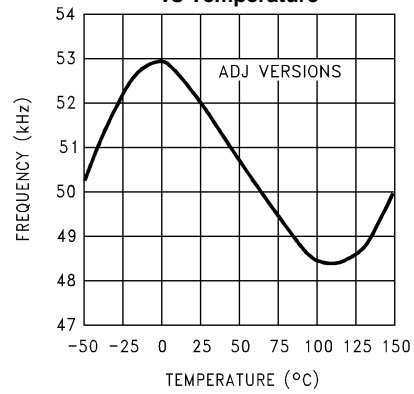

Figure 27.

Maximum Power Dissipation (DDPAK/TO-263)⁽¹⁾

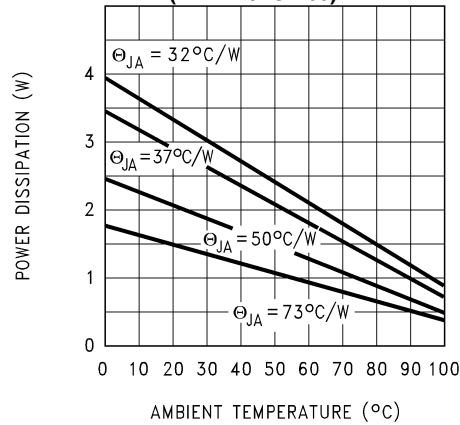
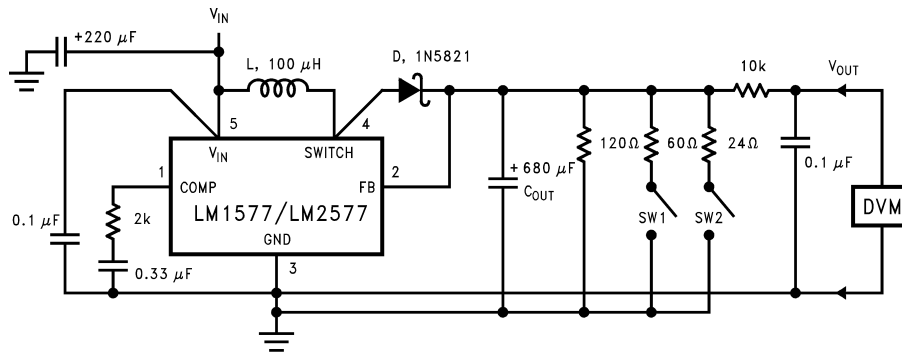

Figure 28.

(1) If the DDPAK/TO-263 package is used, the thermal resistance can be reduced by increasing the PC board copper area thermally connected to the package. Using 0.5 square inches of copper area, θ_{JA} is 50°C/W; with 1 square inch of copper area, θ_{JA} is 37°C/W; and with 1.6 or more square inches of copper area, θ_{JA} is 32°C/W.

LM1577-12, LM2577-12 TEST CIRCUIT



L = 415-0930 (AIE)
 D = any manufacturer
 C_{OUT} = Sprague Type 673D
 Electrolytic 680 μ F, 20V
Note: Pin numbers shown are for TO-220 (T) package

Figure 29. Circuit Used to Specify System Parameters for 12V Versions

LM1577-15, LM2577-15 Test Circuit

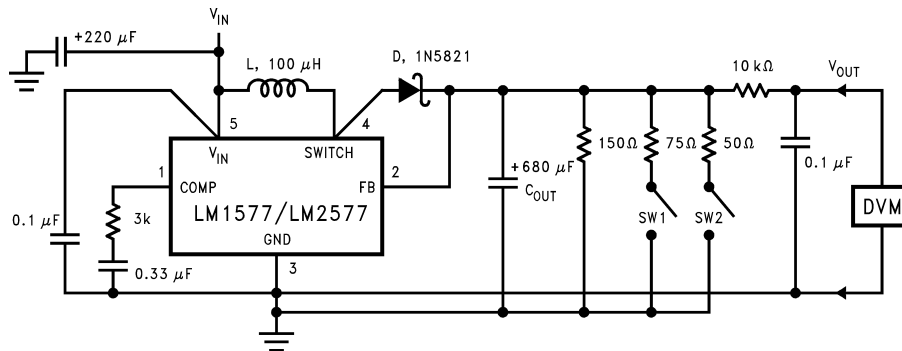

L = 415-0930 (AIE)
 D = any manufacturer
 C_{OUT} = Sprague Type 673D
 Electrolytic 680 μ F, 20V
Note: Pin numbers shown are for TO-220 (T) package

Figure 30. Circuit Used to Specify System Parameters for 15V Versions

LM1577-ADJ, LM2577-ADJ Test Circuit

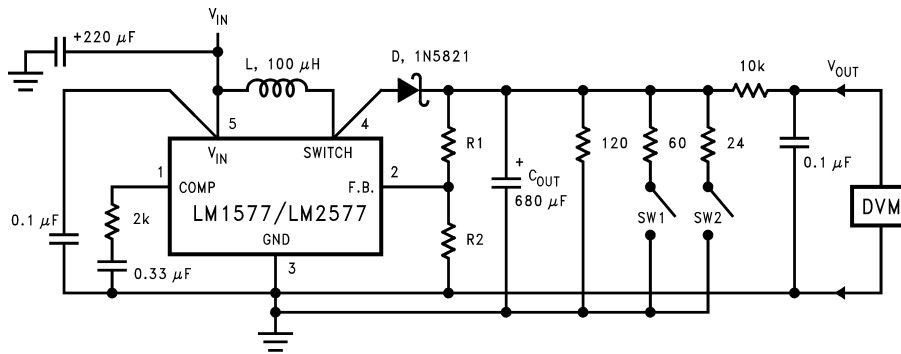

- L = 415-0930 (AIE)
- D = any manufacturer
- C_{OUT} = Sprague Type 673D
Electrolytic 680 μF, 20V
- R1 = 48.7k in series with 511Ω (1%)
- R2 = 5.62k (1%)
- Note:** Pin numbers shown are for TO-220 (T) package

Figure 31. Circuit Used to Specify System Parameters for ADJ Versions

Application Hints

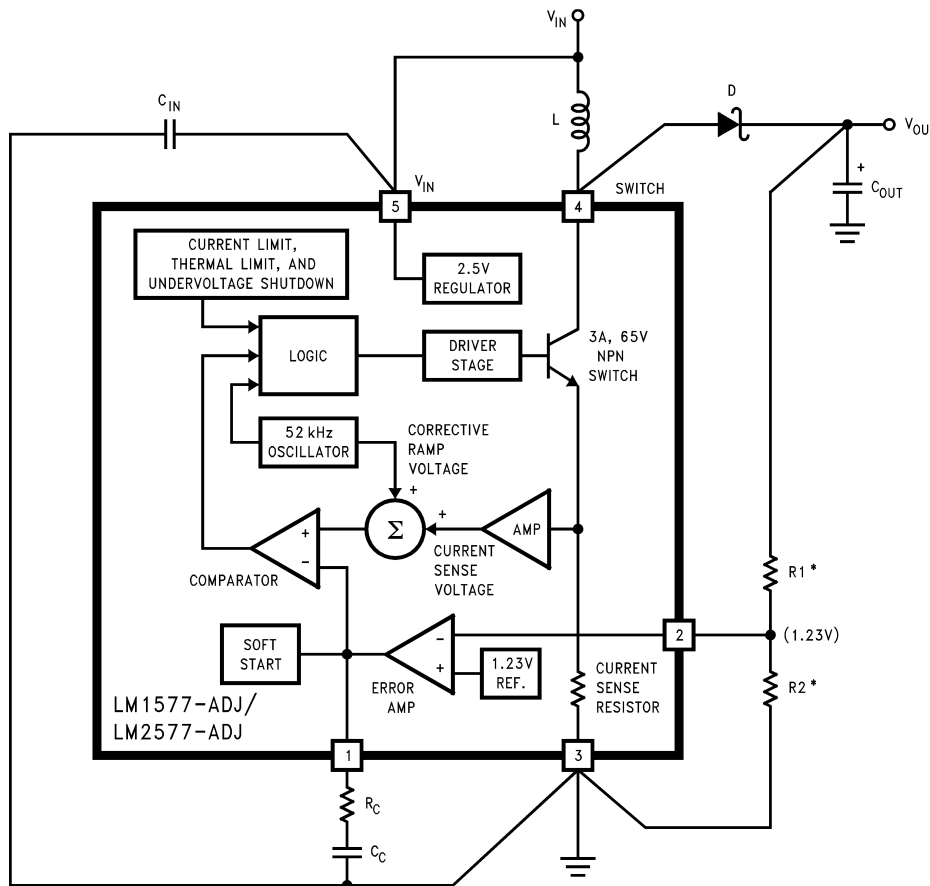

- Note:** Pin numbers shown are for TO-220 (T) package
- *Resistors are internal to LM1577/LM2577 for 12V and 15V versions.

Figure 32. LM1577/LM2577 Block Diagram and Boost Regulator Application

STEP-UP (BOOST) REGULATOR

Figure 32 shows the LM1577-ADJ/LM2577-ADJ used as a Step-Up Regulator. This is a switching regulator used for producing an output voltage greater than the input supply voltage. The LM1577-12/LM2577-12 and LM1577-15/LM2577-15 can also be used for step-up regulators with 12V or 15V outputs (respectively), by tying the feedback pin directly to the regulator output.

A basic explanation of how it works is as follows. The LM1577/LM2577 turns its output switch on and off at a frequency of 52 kHz, and this creates energy in the inductor (L). When the NPN switch turns on, the inductor current charges up at a rate of V_{IN}/L , storing current in the inductor. When the switch turns off, the lower end of the inductor flies above V_{IN} , discharging its current through diode (D) into the output capacitor (C_{OUT}) at a rate of $(V_{OUT} - V_{IN})/L$. Thus, energy stored in the inductor during the switch on time is transferred to the output during the switch off time. The output voltage is controlled by the amount of energy transferred which, in turn, is controlled by modulating the peak inductor current. This is done by feeding back a portion of the output voltage to the error amp, which amplifies the difference between the feedback voltage and a 1.230V reference. The error amp output voltage is compared to a voltage proportional to the switch current (i.e., inductor current during the switch on time).

The comparator terminates the switch on time when the two voltages are equal, thereby controlling the peak switch current to maintain a constant output voltage.

Voltage and current waveforms for this circuit are shown in Figure 33, and formulas for calculating them are given in Table 1.

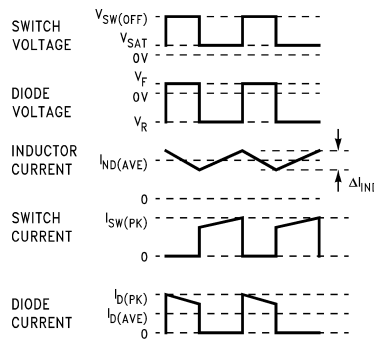

Figure 33. Step-Up Regulator Waveforms

Table 1. Step-Up Regulator Formulas⁽¹⁾

Duty Cycle	D	$\frac{V_{OUT} + V_F - V_{IN}}{V_{OUT} + V_F - V_{SAT}} \approx \frac{V_{OUT} - V_{IN}}{V_{OUT}}$
Average Inductor Current	$I_{IND(AVE)}$	$\frac{I_{LOAD}}{1 - D}$
Inductor Current Ripple	ΔI_{IND}	$\frac{V_{IN} - V_{SAT}}{L} \frac{D}{52,000}$
Peak Inductor Current	$I_{IND(PK)}$	$\frac{I_{LOAD(max)}}{1 - D_{(max)}} + \frac{\Delta I_{IND}}{2}$
Peak Switch Current	$I_{SW(PK)}$	$\frac{I_{LOAD(max)}}{1 - D_{(max)}} + \frac{\Delta I_{IND}}{2}$
Switch Voltage When Off	$V_{SW(OFF)}$	$V_{OUT} + V_F$
Diode Reverse Voltage	V_R	$V_{OUT} - V_{SAT}$
Average Diode Current	$I_{D(AVE)}$	I_{LOAD}
Peak Diode Current	$I_{D(PK)}$	$\frac{I_{LOAD}}{1 - D_{(max)}} + \frac{\Delta I_{IND}}{2}$
Power Dissipation of LM1577/2577	P_D	$0.25\Omega \left(\frac{I_{LOAD}}{1 - D}\right)^2 D + \frac{I_{LOAD} D V_{IN}}{50(1 - D)}$

(1) V_F = Forward Biased Diode Voltage
 I_{LOAD} = Output Load Current

STEP-UP REGULATOR DESIGN PROCEDURE

The following design procedure can be used to select the appropriate external components for the circuit in [Figure 32](#), based on these system requirements.

Given:

- $V_{IN(min)}$ = Minimum input supply voltage
- V_{OUT} = Regulated output voltage
- $I_{LOAD(max)}$ = Maximum output load current
- Before proceeding any further, determine if the LM1577/LM2577 can provide these values of V_{OUT} and $I_{LOAD(max)}$ when operating with the minimum value of V_{IN} . The upper limits for V_{OUT} and $I_{LOAD(max)}$ are given by the following equations.

$$I_{LOAD(max)} \leq \frac{2.1A \times V_{IN(min)}}{V_{OUT}}$$

where

- $V_{OUT} \leq 60V$
- $V_{OUT} \leq 10 \times V_{IN(min)}$ (3)

These limits must be greater than or equal to the values specified in this application.

1. Inductor Selection (L)

A. Voltage Options:

1. For 12V or 15V output

From [Figure 34](#) (for 12V output) or [Figure 35](#) (for 15V output), identify inductor code for region indicated by $V_{IN(min)}$ and $I_{LOAD(max)}$. The shaded region indicates conditions for which the LM1577/LM2577 output switch would be operating beyond its switch current rating. The minimum operating voltage for the LM1577/LM2577 is 3.5V.

From here, **proceed to step C**.

2. For Adjustable version

Preliminary calculations:

The inductor selection is based on the calculation of the following three parameters:

$D_{(max)}$, the maximum switch duty cycle ($0 \leq D \leq 0.9$):

$$D_{(max)} = \frac{V_{OUT} + V_F - V_{IN(min)}}{V_{OUT} + V_F - 0.6V} \quad (4)$$

where $V_F = 0.5V$ for Schottky diodes and $0.8V$ for fast recovery diodes (typically);

$E \cdot T$, the product of volts \times time that charges the inductor:

$$E \cdot T = \frac{D_{(max)} (V_{IN(min)} - 0.6V) 10^6}{52,000 \text{ Hz}} \quad (V \cdot \mu s) \quad (5)$$

$I_{IND,DC}$, the average inductor current under full load;

$$I_{IND,DC} = \frac{1.05 \times I_{LOAD(max)}}{1 - D_{(max)}} \quad (6)$$

B. Identify Inductor Value:

1. From [Figure 36](#), identify the inductor code for the region indicated by the intersection of $E \cdot T$ and $I_{IND,DC}$. This code gives the inductor value in microhenries. The L or H prefix signifies whether the inductor is rated for a maximum $E \cdot T$ of $90 V \cdot \mu s$ (L) or $250 V \cdot \mu s$ (H).

2. If $D < 0.85$, go on to step C. If $D \geq 0.85$, then calculate the minimum inductance needed to ensure the switching regulator's stability:

$$L_{MIN} = \frac{6.4 (V_{IN(min)} - 0.6V) (2D_{(max)} - 1)}{1 - D_{(max)}} \quad (\mu H) \quad (7)$$

If L_{MIN} is smaller than the inductor value found in step B1, go on to step C. Otherwise, the inductor value found in step B1 is too low; an appropriate inductor code should be obtained from the graph as follows:

1. Find the lowest value inductor that is greater than L_{MIN} .

2. Find where $E \cdot T$ intersects this inductor value to determine if it has an L or H prefix. If $E \cdot T$ intersects both the L and H regions, select the inductor with an H prefix.

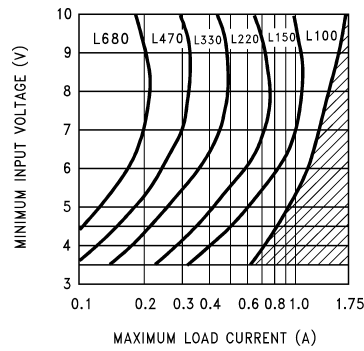

Figure 34. LM2577-12 Inductor Selection Guide

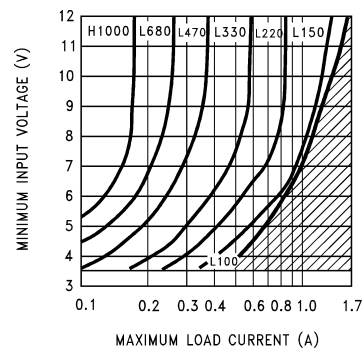
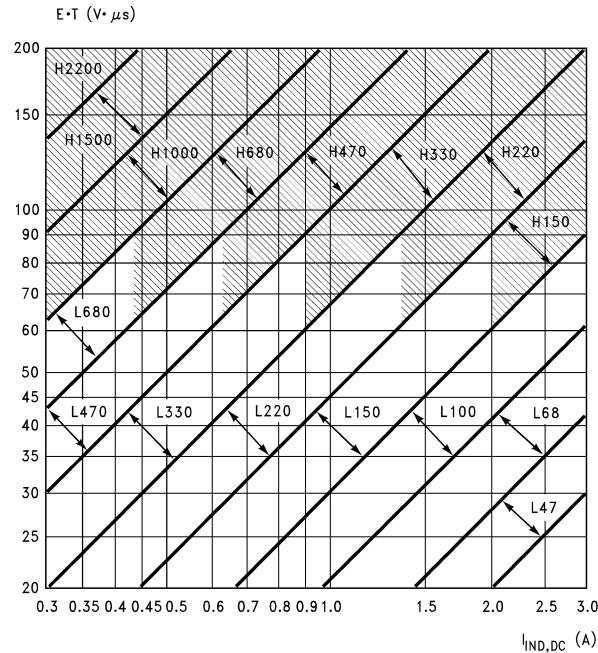

Figure 35. LM2577-15 Inductor Selection Guide



Note: These charts assume that the inductor ripple current is approximately 20% to 30% of the average inductor current (when the regulator is under full load). Greater ripple current causes higher peak switch currents and greater output ripple voltage; lower ripple current is achieved with larger-value inductors. The factor of 20 to 30% is chosen as a convenient balance between the two extremes.

Figure 36. LM1577-ADJ/LM2577-ADJ Inductor Selection Graph

- C. Select an inductor from [Table 2](#) which cross-references the inductor codes to the part numbers of three different manufacturers. Complete specifications for these inductors are available from the respective manufacturers. The inductors listed in this table have the following characteristics:
- *AIE*: ferrite, pot-core inductors; Benefits of this type are low electro-magnetic interference (EMI), small physical size, and very low power dissipation (core loss). Be careful not to operate these inductors too far beyond their maximum ratings for $E \cdot T$ and peak current, as this will saturate the core.
 - *Pulse*: powdered iron, toroid core inductors; Benefits are low EMI and ability to withstand $E \cdot T$ and peak current above rated value better than ferrite cores.
 - *Renco*: ferrite, bobbin-core inductors; Benefits are low cost and best ability to withstand $E \cdot T$ and peak current above rated value. Be aware that these inductors generate more EMI than the other types, and this may interfere with signals sensitive to noise.

Table 2. Table of Standardized Inductors and Manufacturer's Part Numbers⁽¹⁾

Inductor Code	Manufacturer's Part Number		
	Schott	Pulse	Renco
L47	67126980	PE - 53112	RL2442
L68	67126990	PE - 92114	RL2443
L100	67127000	PE - 92108	RL2444
L150	67127010	PE - 53113	RL1954
L220	67127020	PE - 52626	RL1953
L330	67127030	PE - 52627	RL1952
L470	67127040	PE - 53114	RL1951
L680	67127050	PE - 52629	RL1950
H150	67127060	PE - 53115	RL2445
H220	67127070	PE - 53116	RL2446
H330	67127080	PE - 53117	RL2447
H470	67127090	PE - 53118	RL1961
H680	67127100	PE - 53119	RL1960
H1000	67127110	PE - 53120	RL1959
H1500	67127120	PE - 53121	RL1958
H2200	67127130	PE - 53122	RL2448

- (1) **Schott Corp.**, (612) 475-1173
 1000 Parkers Lake Rd., Wayzata, MN 55391
Pulse Engineering, (619) 268-2400
 P.O. Box 12235, San Diego, CA 92112
Renco Electronics Inc., (516) 586-5566
 60 Jeffryn Blvd. East, Deer Park, NY 11729

2. Compensation Network (R_C , C_C) and Output Capacitor (C_{OUT}) Selection

R_C and C_C form a pole-zero compensation network that stabilizes the regulator. The values of R_C and C_C are mainly dependant on the regulator voltage gain, $I_{LOAD(max)}$, L and C_{OUT} . The following procedure calculates values for R_C , C_C , and C_{OUT} that ensure regulator stability. Be aware that this procedure doesn't necessarily result in R_C and C_C that provide optimum compensation. In order to ensure optimum compensation, one of the standard procedures for testing loop stability must be used, such as measuring V_{OUT} transient response when pulsing I_{LOAD} (see [Figure 39](#)).

A. First, calculate the maximum value for R_C .

$$R_C \leq \frac{750 \times I_{LOAD(max)} \times V_{OUT}^2}{V_{IN(min)}^2} \quad (8)$$

Select a resistor less than or equal to this value, and it should also be no greater than 3 k Ω .

B. Calculate the minimum value for C_{OUT} using the following two equations.

$$C_{OUT} \geq \frac{0.19 \times L \times R_C \times I_{LOAD(max)}}{V_{IN(min)} \times V_{OUT}}$$

and

$$C_{OUT} \geq \frac{V_{IN(min)} \times R_C \times (V_{IN(min)} + (3.74 \times 10^5 \times L))}{487,800 \times V_{OUT}^3} \quad (9)$$

The larger of these two values is the minimum value that ensures stability.

C. Calculate the minimum value of C_C .

$$C_C \geq \frac{58.5 \times V_{OUT}^2 \times C_{OUT}}{R_C^2 \times V_{IN(min)}} \quad (10)$$

The compensation capacitor is also part of the soft start circuitry. When power to the regulator is turned on, the switch duty cycle is allowed to rise at a rate controlled by this capacitor (with no control on the duty cycle, it would immediately rise to 90%, drawing huge currents from the input power supply). In order to operate properly, the soft start circuit requires $C_C \geq 0.22 \mu\text{F}$.

The value of the output filter capacitor is normally large enough to require the use of aluminum electrolytic capacitors. Table 3 lists several different types that are recommended for switching regulators, and the following parameters are used to select the proper capacitor.

Working Voltage (WVDC): Choose a capacitor with a working voltage at least 20% higher than the regulator output voltage.

Ripple Current: This is the maximum RMS value of current that charges the capacitor during each switching cycle. For step-up and flyback regulators, the formula for ripple current is

$$I_{\text{RIPPLE(RMS)}} = \frac{I_{\text{LOAD(max)}} \times D_{\text{(max)}}}{1 - D_{\text{(max)}}} \quad (11)$$

Choose a capacitor that is rated at least 50% higher than this value at 52 kHz.

Equivalent Series Resistance (ESR) : This is the primary cause of output ripple voltage, and it also affects the values of R_C and C_C needed to stabilize the regulator. As a result, the preceding calculations for C_C and R_C are only valid if ESR doesn't exceed the maximum value specified by the following equations.

$$\text{ESR} \leq \frac{0.01 \times V_{\text{OUT}}}{I_{\text{RIPPLE(P-P)}}} \text{ and } \leq \frac{8.7 \times (10) - 3 \times V_{\text{IN}}}{I_{\text{LOAD(max)}}}$$

where

$$I_{\text{RIPPLE(P-P)}} = \frac{1.15 \times I_{\text{LOAD(max)}}}{1 - D_{\text{(max)}}} \quad (12)$$

Select a capacitor with ESR, at 52 kHz, that is less than or equal to the lower value calculated. Most electrolytic capacitors specify ESR at 120 Hz which is 15% to 30% higher than at 52 kHz. Also, be aware that ESR increases by a factor of 2 when operating at -20°C .

In general, low values of ESR are achieved by using large value capacitors ($C \geq 470 \mu\text{F}$), and capacitors with high WVDC, or by paralleling smaller-value capacitors.

3. Output Voltage Selection (R1 and R2)

This section is for applications using the LM1577-ADJ/LM2577-ADJ. Skip this section if the LM1577-12/LM2577-12 or LM1577-15/LM2577-15 is being used.

With the LM1577-ADJ/LM2577-ADJ, the output voltage is given by

$$V_{\text{OUT}} = 1.23\text{V} (1 + R1/R2) \quad (13)$$

Resistors R1 and R2 divide the output down so it can be compared with the LM1577-ADJ/LM2577-ADJ internal 1.23V reference. For a given desired output voltage V_{OUT} , select R1 and R2 so that

$$\frac{R1}{R2} = \frac{V_{\text{OUT}}}{1.23\text{V}} - 1 \quad (14)$$

4. Input Capacitor Selection (C_{IN})

The switching action in the step-up regulator causes a triangular ripple current to be drawn from the supply source. This in turn causes noise to appear on the supply voltage. For proper operation of the LM1577, the input voltage should be decoupled. Bypassing the Input Voltage pin directly to ground with a good quality, low ESR, 0.1 μF capacitor (leads as short as possible) is normally sufficient.

Table 3. Aluminum Electrolytic Capacitors Recommended for Switching Regulators

Cornell Dublier —Types 239, 250, 251, UFT, 300, or 350	
	P.O. Box 128, Pickens, SC 29671 (803) 878-6311
Nichicon —Types PF, PX, or PZ	
	927 East Parkway, Schaumburg, IL 60173 (708) 843-7500
Sprague —Types 672D, 673D, or 674D	
	Box 1, Sprague Road, Lansing, NC 28643 (919) 384-2551
United Chemi-Con —Types LX, SXF, or SXJ	
	9801 West Higgins Road, Rosemont, IL 60018 (708) 696-2000

If the LM1577 is located far from the supply source filter capacitors, an additional large electrolytic capacitor (e.g. 47 μ F) is often required.

5. Diode Selection (D)

The switching diode used in the boost regulator must withstand a reverse voltage equal to the circuit output voltage, and must conduct the peak output current of the LM2577. A suitable diode must have a minimum reverse breakdown voltage greater than the circuit output voltage, and should be rated for average and peak current greater than $I_{LOAD(max)}$ and $I_{D(PK)}$. Schottky barrier diodes are often favored for use in switching regulators. Their low forward voltage drop allows higher regulator efficiency than if a (less expensive) fast recovery diode was used. See [Table 4](#) for recommended part numbers and voltage ratings of 1A and 3A diodes.

Table 4. Diode Selection Chart

V_{OUT} (max)	Schottky		Fast Recovery	
	1A	3A	1A	3A
20V	1N5817	1N5820		
	MBR120P	MBR320P		
30V	1N5818	1N5821		
	MBR130P	MBR330P		
40V	11DQ03	31DQ03		
	1N5819	1N5822		
50V	MBR140P	MBR340P		
	11DQ04	31DQ04		
100V	MBR150	MBR350	1N4933	
	11DQ05	31DQ05	MUR105	
			1N4934	MR851
			HER102	30DL1
			MUR110	MR831
			10DL1	HER302

BOOST REGULATOR CIRCUIT EXAMPLE

By adding a few external components (as shown in [Figure 37](#)), the LM2577 can be used to produce a regulated output voltage that is greater than the applied input voltage. Typical performance of this regulator is shown in [Figure 38](#) and [Figure 39](#). The switching waveforms observed during the operation of this circuit are shown in [Figure 40](#).

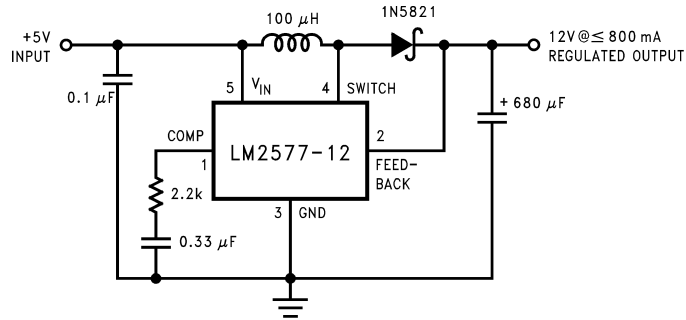

Note: Pin numbers shown are for TO-220 (T) package.

Figure 37. Step-up Regulator Delivers 12V from a 5V Input

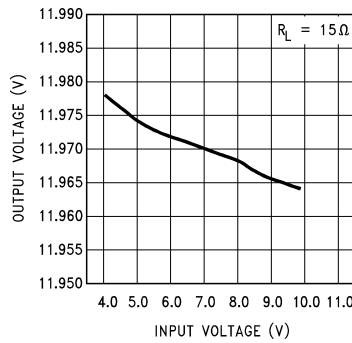
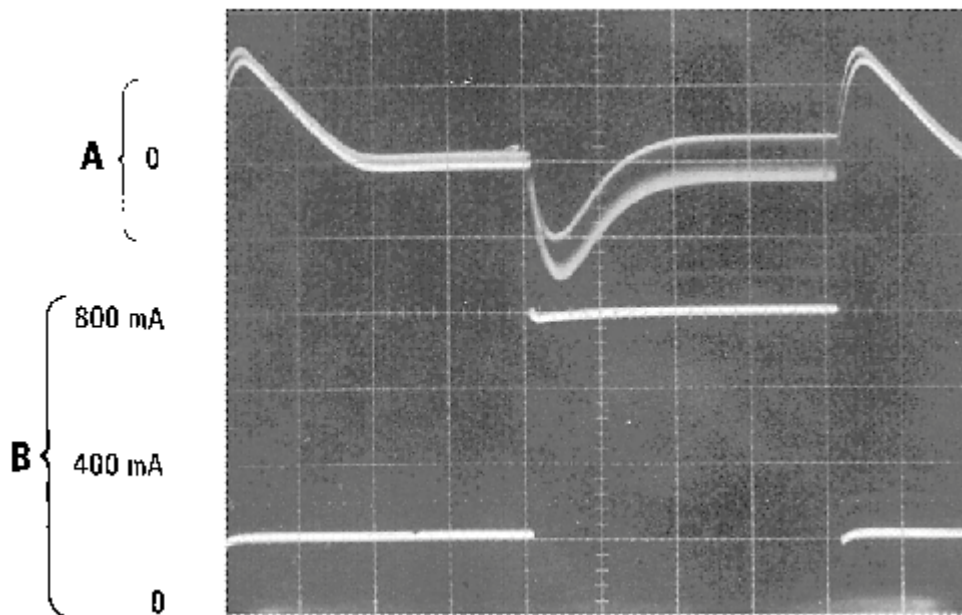
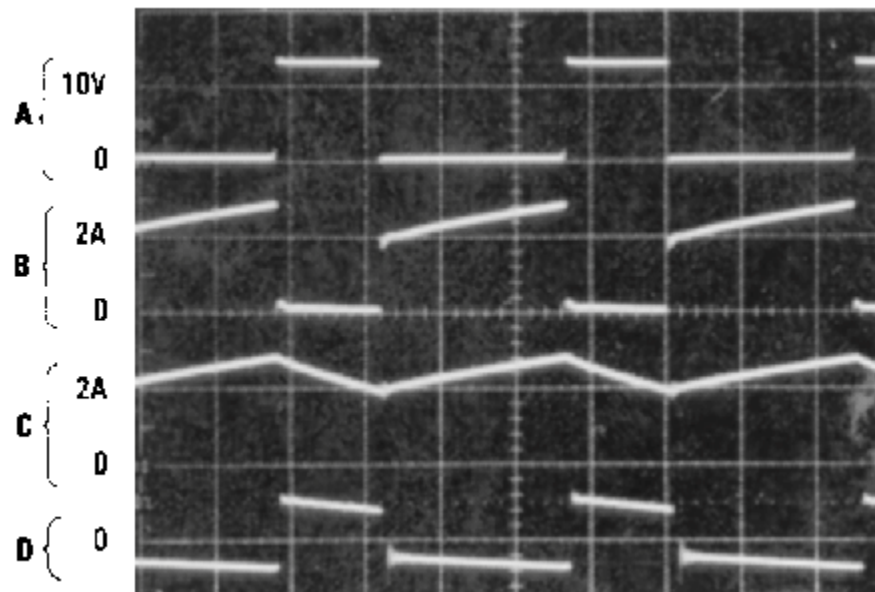

Figure 38. Line Regulation (Typical) of Step-Up Regulator of Figure 37



A: Output Voltage Change, 100 mV/div. (AC-coupled)
 B: Load current, 0.2 A/div
 Horizontal: 5 ms/div

Figure 39. Load Transient Response of Step-Up Regulator of Figure 37



A: Switch pin voltage, 10 V/div
 B: Switch pin current, 2 A/div
 C: Inductor current, 2 A/div
 D: Output ripple voltage, 100 mV/div (AC-coupled)
 Horizontal: 5 μ s/div

Figure 40. Switching Waveforms of Step-Up Regulator of Figure 37

FLYBACK REGULATOR

A Flyback regulator can produce single or multiple output voltages that are lower or greater than the input supply voltage. Figure 42 shows the LM1577/LM2577 used as a flyback regulator with positive and negative regulated outputs. Its operation is similar to a step-up regulator, except the output switch controls the primary current of a flyback transformer. Note that the primary and secondary windings are out of phase, so no current flows through secondary when current flows through the primary. This allows the primary to charge up the transformer core when the switch is on. When the switch turns off, the core discharges by sending current through the secondary, and this produces voltage at the outputs. The output voltages are controlled by adjusting the peak primary current, as described in the [STEP-UP \(BOOST\) REGULATOR](#) section.

Voltage and current waveforms for this circuit are shown in Figure 41, and formulas for calculating them are given in Table 5.

FLYBACK REGULATOR DESIGN PROCEDURE

1. Transformer Selection

A family of standardized flyback transformers is available for creating flyback regulators that produce dual output voltages, from $\pm 10V$ to $\pm 15V$, as shown in Figure 42. Table 6 lists these transformers with the input voltage, output voltages and maximum load current they are designed for.

2. Compensation Network (C_C , R_C) and Output Capacitor (C_{OUT}) Selection

As explained in the Step-Up Regulator Design Procedure, C_C , R_C and C_{OUT} must be selected as a group. The following procedure is for a dual output flyback regulator with equal turns ratios for each secondary (i.e., both output voltages have the same magnitude). The equations can be used for a single output regulator by changing $\sum I_{LOAD(max)}$ to $I_{LOAD(max)}$ in the following equations.

A. First, calculate the maximum value for R_C .

$$R_C \leq \frac{750 \times \Sigma I_{LOAD(max)} \times (15V + V_{IN(min)N})^2}{V_{IN(min)}^2} \tag{15}$$

Where $\Sigma I_{LOAD(max)}$ is the sum of the load current (magnitude) required from both outputs. Select a resistor less than or equal to this value, and no greater than 3 k Ω .

B. Calculate the minimum value for ΣC_{OUT} (sum of C_{OUT} at both outputs) using the following two equations.

$$C_{OUT} \geq \frac{0.19 \times R_C \times L_P \times \Sigma I_{LOAD(max)}}{15V \times V_{IN(min)}}$$

and

$$C_{OUT} \geq \frac{V_{IN(min)} \times R_C \times N^2 \times (V_{IN(min)} + (3.74 \times 10^5 \times L_P))}{487,800 \times (15V)^2 \times (15V + V_{IN(min)} \times N)} \tag{16}$$

The larger of these two values must be used to ensure regulator stability.

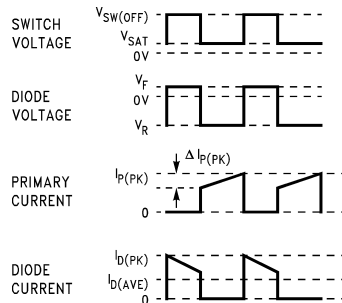
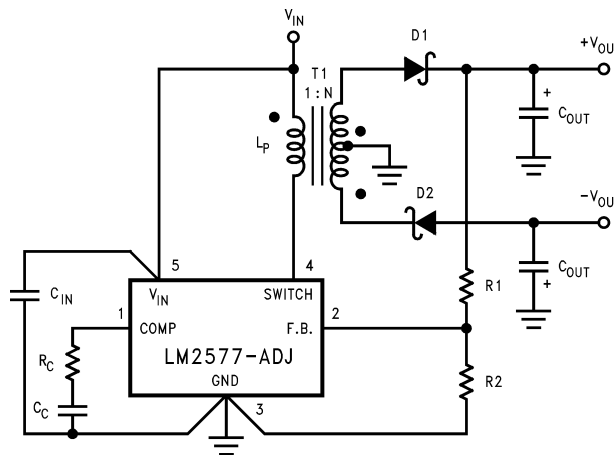

Figure 41. Flyback Regulator Waveforms



T1 = Pulse Engineering, PE-65300
D1, D2 = 1N5821

Figure 42. LM1577-ADJ/LM2577-ADJ Flyback Regulator with \pm Outputs

Table 5. Flyback Regulator Formulas

Duty Cycle	D	$\frac{V_{OUT} + V_F}{N(V_{IN} - V_{SAT}) + V_{OUT} + V_F} \approx \frac{V_{OUT}}{N(V_{IN}) + V_{OUT}}$	(17)
Primary Current Variation	ΔI_P	$\frac{D(V_{IN} - V_{SAT})}{L_P \times 52,000}$	(18)

Table 5. Flyback Regulator Formulas (continued)

Peak Primary Current	$I_{P(PK)}$	$\frac{N}{\eta} \times \frac{\Sigma I_{LOAD}}{1-D} + \frac{\Delta I_{PK}}{2}$	(19)
Switch Voltage when Off	$V_{SW(OFF)}$	$V_{IN} + \frac{V_{OUT} + V_F}{N}$	(20)
Diode Reverse Voltage	V_R	$V_{OUT} + N(V_{IN} - V_{SAT})$	
Average Diode Current	$I_{D(AVE)}$	I_{LOAD}	
Peak Diode Current	$I_{D(PK)}$	$\frac{I_{LOAD}}{1-D} + \frac{\Delta I_{IND}}{2}$	(21)
Short Circuit Diode Current		$\approx \frac{6A}{N}$	(22)
Power Dissipation of LM1577/LM2577	P_D	$0.25\Omega \left(\frac{N \Sigma I_{LOAD}}{1-D} \right)^2 + \frac{N I_{LOAD} D}{50(1-D)} V_{IN}$	(23)

$$N = \text{Transformer Turns Ratio} = \frac{\text{number of secondary turns}}{\text{number of primary turns}}$$

$$\eta = \text{Transformer Efficiency (typically 0.95)}$$

$$\Sigma I_{LOAD} = |I_{LOAD}| + |-I_{LOAD}|$$

C. Calculate the minimum value of C_C

$$C_C \geq \frac{58.5 \times C_{OUT} \times V_{OUT} \times (V_{OUT} + (V_{IN(min)} \times N))}{R_C^2 \times V_{IN(min)} \times N} \quad (24)$$

D. Calculate the maximum ESR of the $+V_{OUT}$ and $-V_{OUT}$ output capacitors in parallel.

$$ESR + \parallel ESR \leq \frac{8.7 \times 10^{-3} \times V_{IN(min)} \times V_{OUT} \times N}{\Sigma I_{LOAD(max)} \times (V_{OUT} + (V_{IN(min)} \times N))} \quad (25)$$

This formula can also be used to calculate the maximum ESR of a single output regulator.

At this point, refer to this same section in the [STEP-UP REGULATOR DESIGN PROCEDURE](#) section for more information regarding the selection of C_{OUT} .

3. Output Voltage Selection

This section is for applications using the LM1577-ADJ/LM2577-ADJ. Skip this section if the LM1577-12/LM2577-12 or LM1577-15/LM2577-15 is being used.

With the LM1577-ADJ/LM2577-ADJ, the output voltage is given by

$$V_{OUT} = 1.23V (1 + R1/R2) \quad (26)$$

Resistors R1 and R2 divide the output voltage down so it can be compared with the LM1577-ADJ/LM2577-ADJ internal 1.23V reference. For a desired output voltage V_{OUT} , select R1 and R2 so that

$$\frac{R1}{R2} = \frac{V_{OUT}}{1.23V} - 1 \quad (27)$$

4. Diode Selection

The switching diode in a flyback converter must withstand the reverse voltage specified by the following equation.

$$V_R = V_{OUT} + \frac{V_{IN}}{N} \quad (28)$$

A suitable diode must have a reverse voltage rating greater than this. In addition it must be rated for more than the average and peak diode currents listed in [Table 5](#).

5. Input Capacitor Selection

The primary of a flyback transformer draws discontinuous pulses of current from the input supply. As a result, a flyback regulator generates more noise at the input supply than a step-up regulator, and this requires a larger bypass capacitor to decouple the LM1577/LM2577 V_{IN} pin from this noise. For most applications, a low ESR, 1.0 μF cap will be sufficient, if it is connected very close to the V_{IN} and Ground pins.

Transformer		Input	Dual	Maximum
Type		Voltage	Output	Output
			Voltage	Current
1	$L_P = 100 \mu\text{H}$ $N = 1$	5V	$\pm 10\text{V}$	325 mA
		5V	$\pm 12\text{V}$	275 mA
		5V	$\pm 15\text{V}$	225 mA
		10V	$\pm 10\text{V}$	700 mA
2	$L_P = 200 \mu\text{H}$ $N = 0.5$	10V	$\pm 12\text{V}$	575 mA
		10V	$\pm 15\text{V}$	500 mA
		12V	$\pm 10\text{V}$	800 mA
		12V	$\pm 12\text{V}$	700 mA
3	$L_P = 250 \mu\text{H}$ $N = 0.5$	12V	$\pm 15\text{V}$	575 mA
		15V	$\pm 10\text{V}$	900 mA
		15V	$\pm 12\text{V}$	825 mA
		15V	$\pm 15\text{V}$	700 mA

Table 6. Flyback Transformer Selection Guide

Transformer	Manufacturers' Part Numbers			
	Type	AIE	Pulse	Renco
1		326-0637	PE-65300	RL-2580
2		330-0202	PE-65301	RL-2581
3		330-0203	PE-65302	RL-2582

In addition to this bypass cap, a larger capacitor ($\geq 47 \mu\text{F}$) should be used where the flyback transformer connects to the input supply. This will attenuate noise which may interfere with other circuits connected to the same input supply voltage.

6. Snubber Circuit

A “snubber” circuit is required when operating from input voltages greater than 10V, or when using a transformer with $L_P \geq 200 \mu\text{H}$. This circuit clamps a voltage spike from the transformer primary that occurs immediately after the output switch turns off. Without it, the switch voltage may exceed the 65V maximum rating. As shown in [Figure 43](#), the snubber consists of a fast recovery diode, and a parallel RC. The RC values are selected for switch clamp voltage (V_{CLAMP}) that is 5V to 10V greater than $V_{SW(OFF)}$. Use the following equations to calculate R and C;

$$C \geq \frac{0.02 \times L_P \times I_{P(PK)}^2}{(V_{CLAMP})^2 - (V_{SW(OFF)})^2}$$

$$R \leq \left(\frac{V_{CLAMP} + V_{SW(OFF)} - V_{IN}}{2} \right)^2 \times \left(\frac{19.2 \times 10^{-4}}{L_P \times I_{P(PK)}^2} \right) \quad (29)$$

Power dissipation (and power rating) of the resistor is;

$$P = \left(\frac{V_{CLAMP} + V_{SW(OFF)} - V_{IN}}{2} \right)^2 / R \quad (30)$$

The fast recovery diode must have a reverse voltage rating greater than V_{CLAMP} .

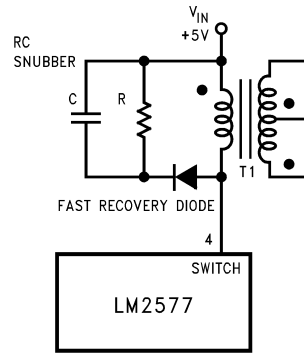
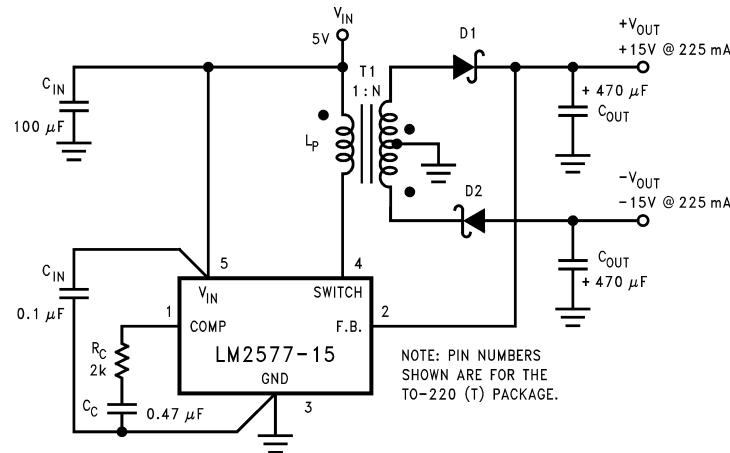

Figure 43. Snubber Circuit

FLYBACK REGULATOR CIRCUIT EXAMPLE

The circuit of Figure 44 produces $\pm 15\text{V}$ (at 225 mA each) from a single 5V input. The output regulation of this circuit is shown in Figure 45 and Figure 47, while the load transient response is shown in Figure 46 and Figure 48. Switching waveforms seen in this circuit are shown in Figure 49.



T1 = Pulse Engineering, PE-65300
D1, D2 = 1N5821

Figure 44. Flyback Regulator Easily Provides Dual Outputs

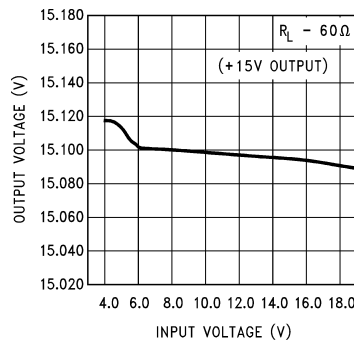
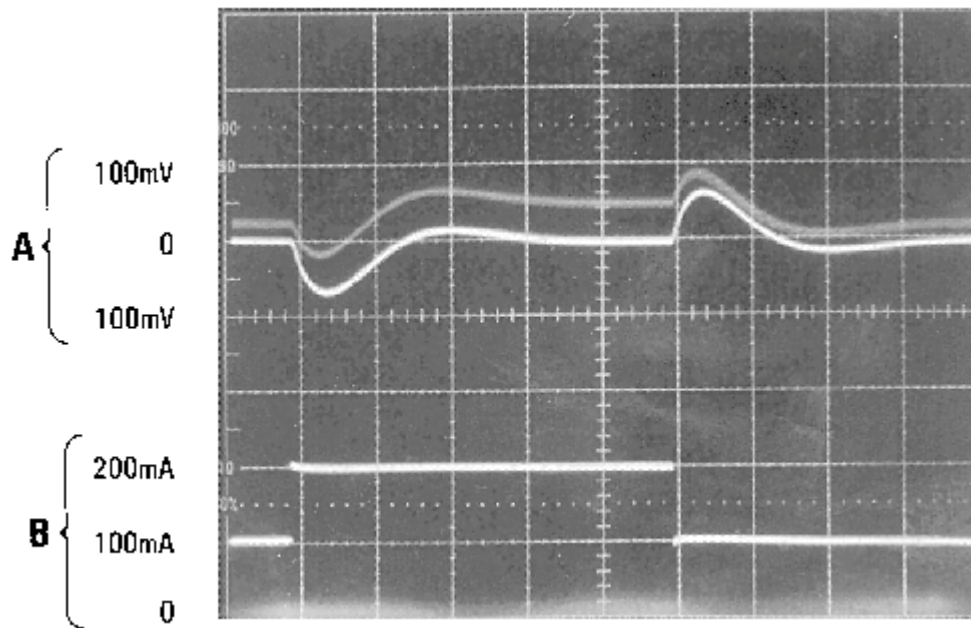

Figure 45. Line Regulation (Typical) of Flyback Regulator of Figure 44, +15V Output



A: Output Voltage Change, 100 mV/div
 B: Output Current, 100 mA/div
 Horizontal: 10 ms/div

Figure 46. Load Transient Response of Flyback Regulator of Figure 44, +15V Output

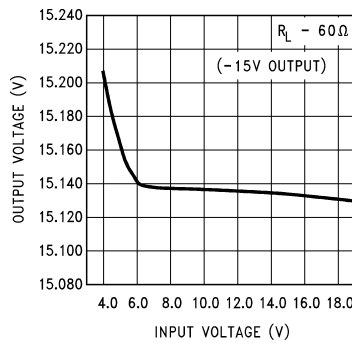
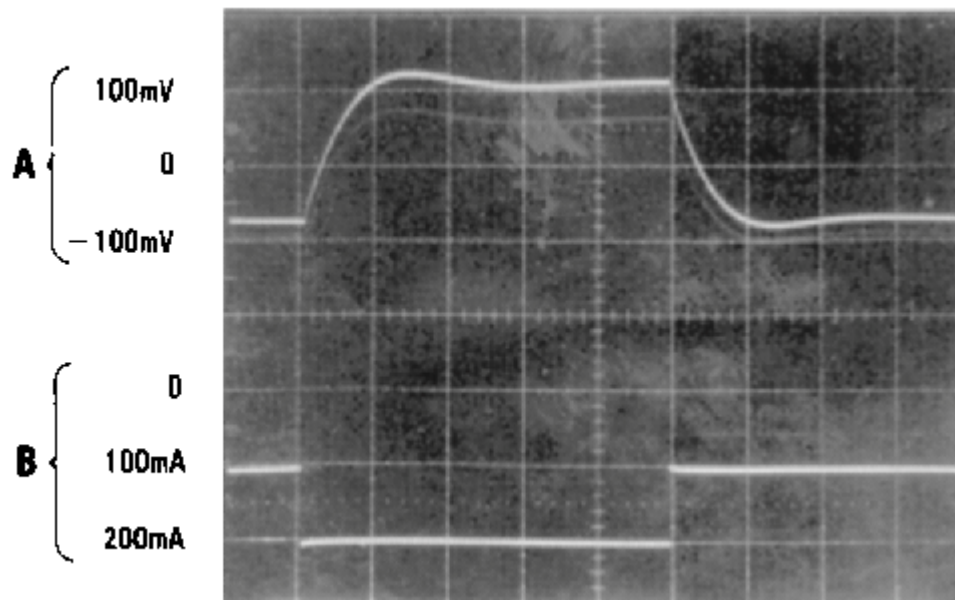
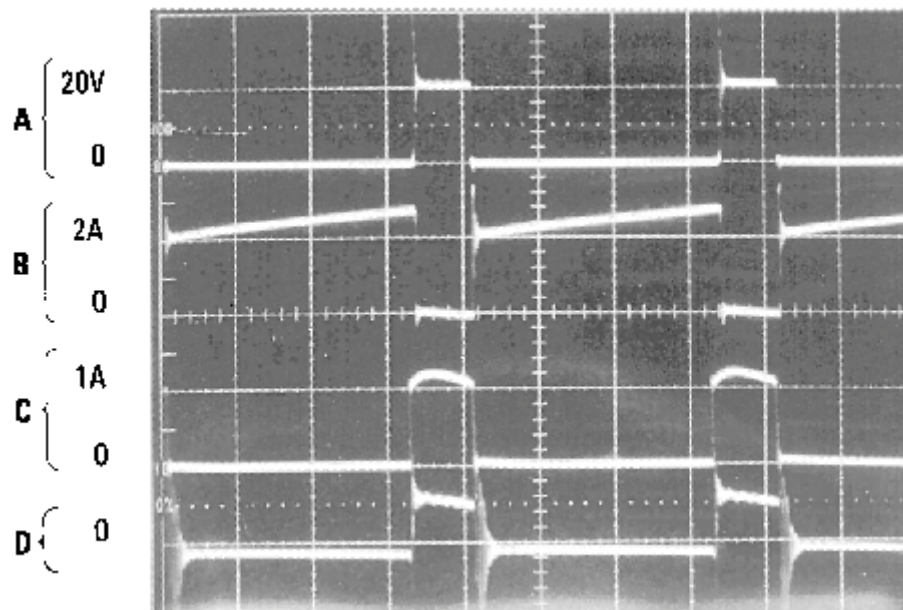

Figure 47. Line Regulation (Typical) of Flyback Regulator of Figure 44, -15V Output



A: Output Voltage Change, 100 mV/div
 B: Output Current, 100 mA/div
 Horizontal: 10 ms/div

Figure 48. Load Transient Response of Flyback Regulator of Figure 44, -15V Output



A: Switch pin voltage, 20 V/div
 B: Primary current, 2 A/div
 C: +15V Secondary current, 1 A/div
 D: +15V Output ripple voltage, 100 mV/div
 Horizontal: 5 µs/div

Figure 49. Switching Waveforms of Flyback Regulator of Figure 44, Each Output Loaded with 60Ω

REVISION HISTORY

Changes from Revision C (April 2013) to Revision D	Page
• Changed layout of National Data Sheet to TI format	29

PACKAGING INFORMATION

Orderable Device	Status (1)	Package Type	Package Drawing	Pins	Package Qty	Eco Plan (2)	Lead/Ball Finish (6)	MSL Peak Temp (3)	Op Temp (°C)	Device Marking (4/5)	Samples
LM2577M-ADJ/NOPB	LIFEBUY	SOIC	DW	24	30	Green (RoHS & no Sb/Br)	CU SN	Level-3-260C-168 HR	-40 to 125	LM2577M -ADJ P+	
LM2577N-ADJ/NOPB	LIFEBUY	PDIP	NBG	16	20	Green (RoHS & no Sb/Br)	CU SN	Level-1-NA-UNLIM	-40 to 125	LM2577N-ADJ P+	
LM2577S-12/NOPB	LIFEBUY	DDPAK/ TO-263	KTT	5	45	Pb-Free (RoHS Exempt)	CU SN	Level-3-245C-168 HR	-40 to 125	LM2577S -12 P+	
LM2577S-ADJ	NRND	DDPAK/ TO-263	KTT	5	45	TBD	Call TI	Call TI	-40 to 125	LM2577S -ADJ P+	
LM2577S-ADJ/NOPB	ACTIVE	DDPAK/ TO-263	KTT	5	45	Pb-Free (RoHS Exempt)	CU SN	Level-3-245C-168 HR	-40 to 125	LM2577S -ADJ P+	Samples
LM2577SX-12/NOPB	LIFEBUY	DDPAK/ TO-263	KTT	5	500	Pb-Free (RoHS Exempt)	CU SN	Level-3-245C-168 HR	-40 to 125	LM2577S -12 P+	
LM2577SX-ADJ	NRND	DDPAK/ TO-263	KTT	5	500	TBD	Call TI	Call TI	-40 to 125	LM2577S -ADJ P+	
LM2577SX-ADJ/NOPB	ACTIVE	DDPAK/ TO-263	KTT	5	500	Pb-Free (RoHS Exempt)	CU SN	Level-3-245C-168 HR	-40 to 125	LM2577S -ADJ P+	Samples
LM2577T-12	LIFEBUY	TO-220	KC	5	45	TBD	Call TI	Call TI	-40 to 125	LM2577T-12 P+	
LM2577T-12/LB03	NRND	TO-220	NDH	5		TBD	Call TI	Call TI		LM2577T-12 P+	
LM2577T-12/LF03	LIFEBUY	TO-220	NDH	5	45	Green (RoHS & no Sb/Br)	CU SN	Level-1-NA-UNLIM		LM2577T-12 P+	
LM2577T-12/NOPB	LIFEBUY	TO-220	KC	5	45	Green (RoHS & no Sb/Br)	CU SN	Level-1-NA-UNLIM	-40 to 125	LM2577T-12 P+	
LM2577T-15	LIFEBUY	TO-220	KC	5	45	TBD	Call TI	Call TI	-40 to 125	LM2577T-15 P+	
LM2577T-15/LB03	LIFEBUY	TO-220	NDH	5	45	TBD	Call TI	Call TI		LM2577T-15 P+	
LM2577T-15/NOPB	LIFEBUY	TO-220	KC	5	45	Green (RoHS & no Sb/Br)	CU SN	Level-1-NA-UNLIM	-40 to 125	LM2577T-15 P+	
LM2577T-ADJ	NRND	TO-220	KC	5	45	TBD	Call TI	Call TI	-40 to 125	LM2577T -ADJ P+	
LM2577T-ADJ/LB02	NRND	TO-220	NEB	5		TBD	Call TI	Call TI		LM2577T	

Orderable Device	Status (1)	Package Type	Package Drawing	Pins	Package Qty	Eco Plan (2)	Lead/Ball Finish (6)	MSL Peak Temp (3)	Op Temp (°C)	Device Marking (4/5)	Samples
										-ADJ P+	
LM2577T-ADJ/LB03	NRND	TO-220	NDH	5	45	TBD	Call TI	Call TI		LM2577T -ADJ P+	
LM2577T-ADJ/LF03	ACTIVE	TO-220	NDH	5	45	Green (RoHS & no Sb/Br)	CU SN	Level-1-NA-UNLIM		LM2577T -ADJ P+	Samples
LM2577T-ADJ/NOPB	ACTIVE	TO-220	KC	5	45	Pb-Free (RoHS Exempt)	CU SN	Level-1-NA-UNLIM	-40 to 125	LM2577T -ADJ P+	Samples

(1) The marketing status values are defined as follows:

ACTIVE: Product device recommended for new designs.

LIFEBUY: TI has announced that the device will be discontinued, and a lifetime-buy period is in effect.

NRND: Not recommended for new designs. Device is in production to support existing customers, but TI does not recommend using this part in a new design.

PREVIEW: Device has been announced but is not in production. Samples may or may not be available.

OBSOLETE: TI has discontinued the production of the device.

(2) Eco Plan - The planned eco-friendly classification: Pb-Free (RoHS), Pb-Free (RoHS Exempt), or Green (RoHS & no Sb/Br) - please check

TBD: The Pb-Free/Green conversion plan has not been defined.

Pb-Free (RoHS): TI's terms "Lead-Free" or "Pb-Free" mean semiconductor products that are compatible with the current RoHS requirements for all 6 substances, including the requirement that lead not exceed 0.1% by weight in homogeneous materials. Where designed to be soldered at high temperatures, TI Pb-Free products are suitable for use in specified lead-free processes.

Pb-Free (RoHS Exempt): This component has a RoHS exemption for either 1) lead-based flip-chip solder bumps used between the die and package, or 2) lead-based die adhesive used between the die and leadframe. The component is otherwise considered Pb-Free (RoHS compatible) as defined above.

Green (RoHS & no Sb/Br): TI defines "Green" to mean Pb-Free (RoHS compatible), and free of Bromine (Br) and Antimony (Sb) based flame retardants (Br or Sb do not exceed 0.1% by weight in homogeneous material)

(3) MSL, Peak Temp. - The Moisture Sensitivity Level rating according to the JEDEC industry standard classifications, and peak solder temperature.

(4) There may be additional marking, which relates to the logo, the lot trace code information, or the environmental category on the device.

(5) Multiple Device Markings will be inside parentheses. Only one Device Marking contained in parentheses and separated by a "~" will appear on a device. If a line is indented then it is a continuation of the previous line and the two combined represent the entire Device Marking for that device.

(6) Lead/Ball Finish - Orderable Devices may have multiple material finish options. Finish options are separated by a vertical ruled line. Lead/Ball Finish values may wrap to two lines if the finish value exceeds the maximum column width.

Important Information and Disclaimer: The information provided on this page represents TI's knowledge and belief as of the date that it is provided. TI bases its knowledge and belief on information provided by third parties, and makes no representation or warranty as to the accuracy of such information. Efforts are underway to better integrate information from third parties. TI has taken and continues to take reasonable steps to provide representative and accurate information but may not have conducted destructive testing or chemical analysis on incoming materials and chemicals. TI and TI suppliers consider certain information to be proprietary, and thus CAS numbers and other limited information may not be available for release.

In no event shall TI's liability arising out of such information exceed the total purchase price of the TI part(s) at issue in this document sold by TI to Customer on an annual basis.

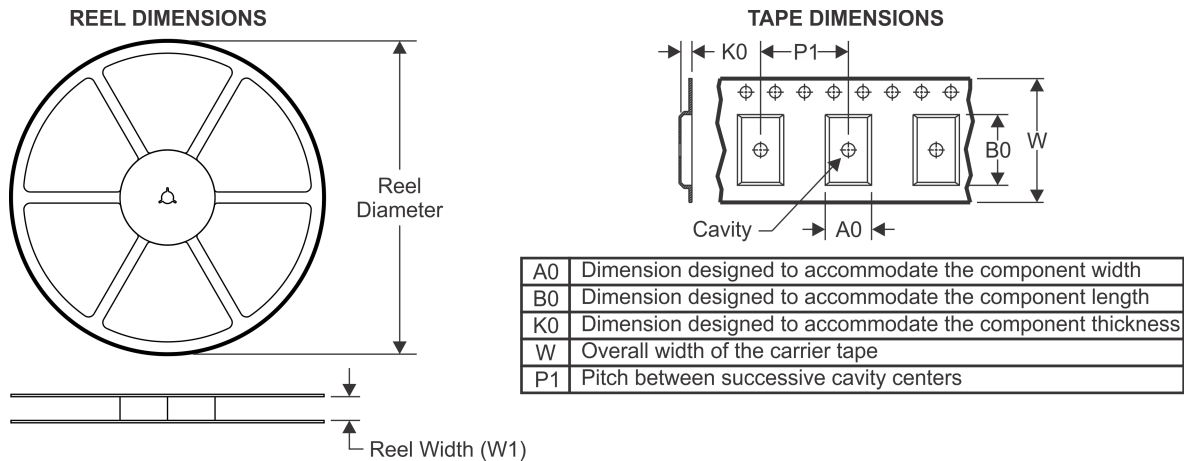
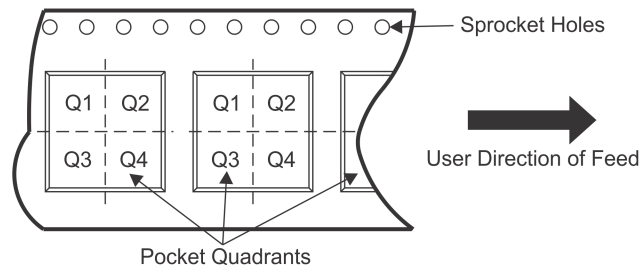
TAPE AND REEL INFORMATION

QUADRANT ASSIGNMENTS FOR PIN 1 ORIENTATION IN TAPE

*All dimensions are nominal

Device	Package Type	Package Drawing	Pins	SPQ	Reel Diameter (mm)	Reel Width W1 (mm)	A0 (mm)	B0 (mm)	K0 (mm)	P1 (mm)	W (mm)	Pin1 Quadrant
LM2577SX-12/NOPB	DDPAK/ TO-263	KTT	5	500	330.0	24.4	10.75	14.85	5.0	16.0	24.0	Q2
LM2577SX-ADJ	DDPAK/ TO-263	KTT	5	500	330.0	24.4	10.75	14.85	5.0	16.0	24.0	Q2
LM2577SX-ADJ/NOPB	DDPAK/ TO-263	KTT	5	500	330.0	24.4	10.75	14.85	5.0	16.0	24.0	Q2

TAPE AND REEL BOX DIMENSIONS



*All dimensions are nominal

Device	Package Type	Package Drawing	Pins	SPQ	Length (mm)	Width (mm)	Height (mm)
LM2577SX-12/NOPB	DDPAK/TO-263	KTT	5	500	367.0	367.0	45.0
LM2577SX-ADJ	DDPAK/TO-263	KTT	5	500	367.0	367.0	45.0
LM2577SX-ADJ/NOPB	DDPAK/TO-263	KTT	5	500	367.0	367.0	45.0

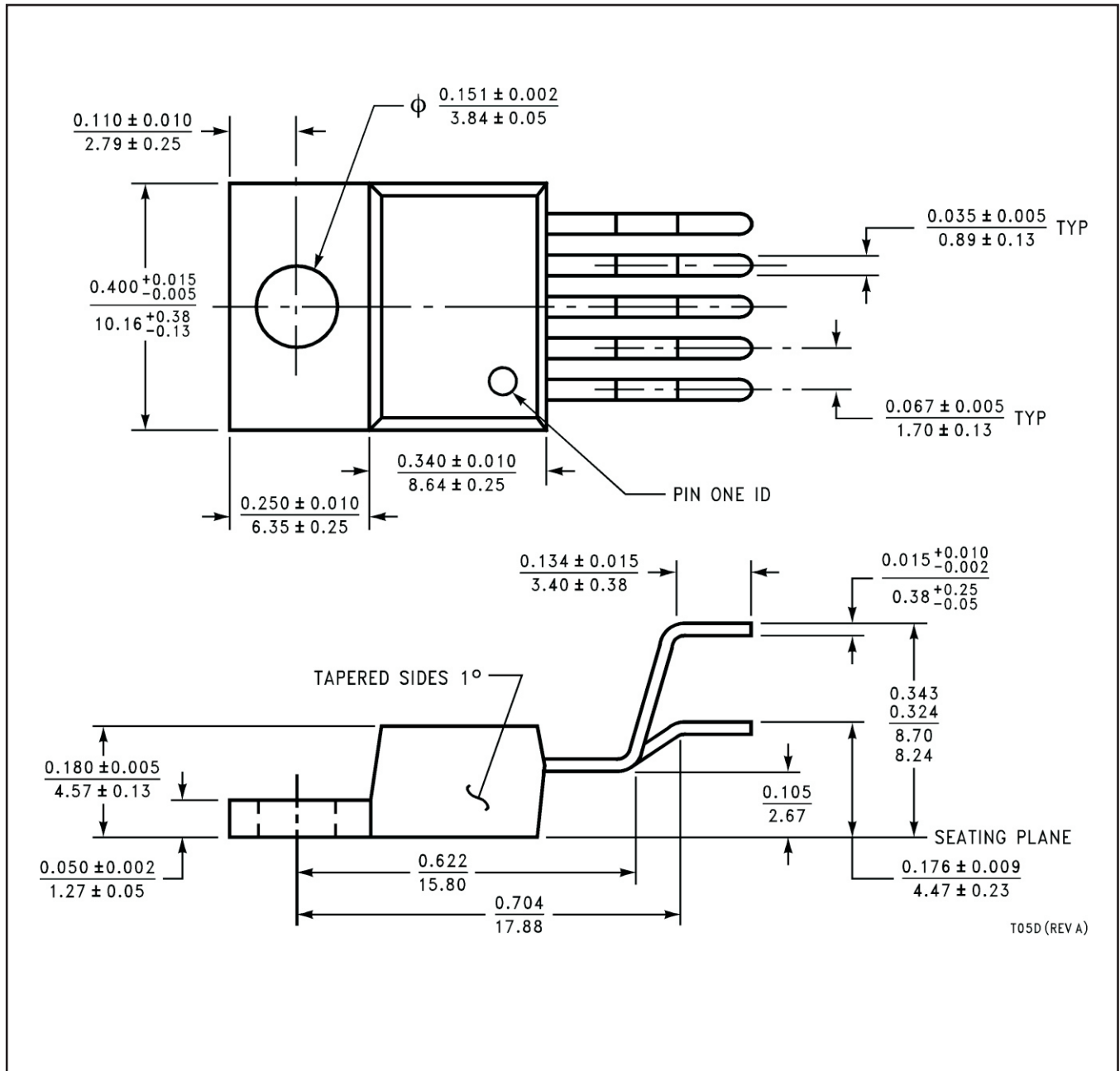
NDH0005D

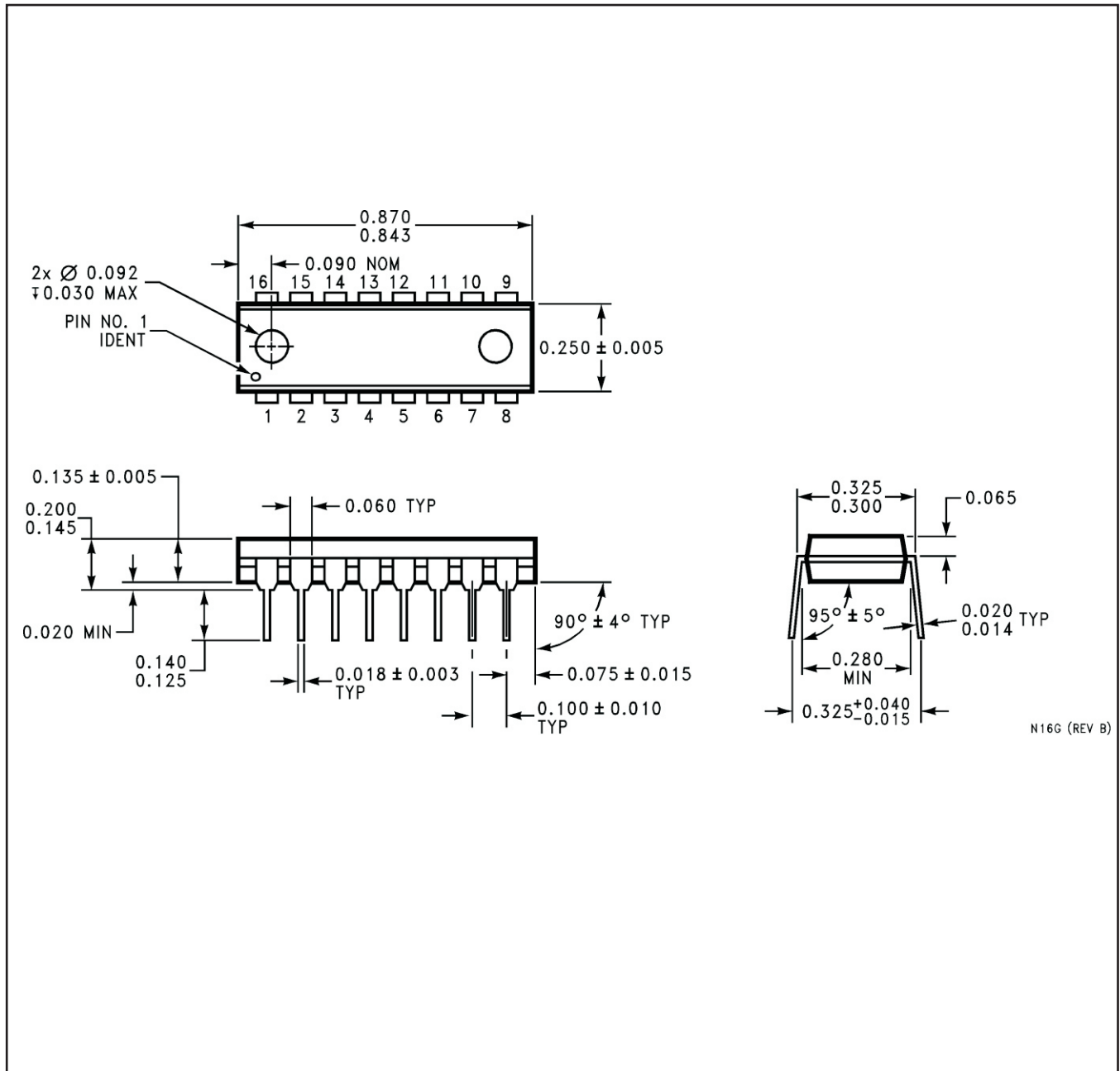

NBG0016G



N16G (REV B)

DW (R-PDSO-G24)

PLASTIC SMALL OUTLINE

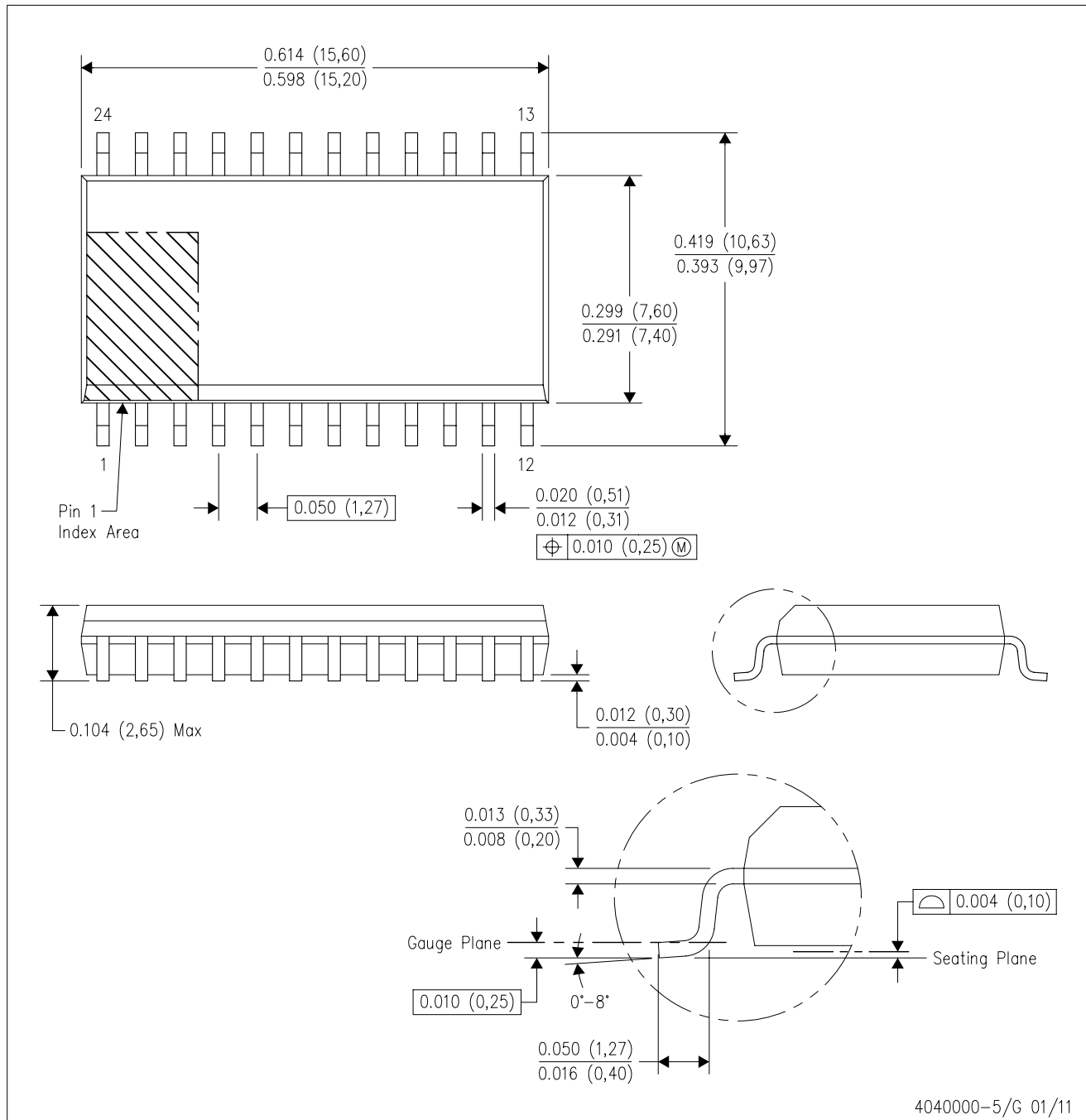

- NOTES:
- A. All linear dimensions are in inches (millimeters). Dimensioning and tolerancing per ASME Y14.5M-1994.
 - B. This drawing is subject to change without notice.
 - C. Body dimensions do not include mold flash or protrusion not to exceed 0.006 (0,15).
 - D. Falls within JEDEC MS-013 variation AD.

KTT0005B

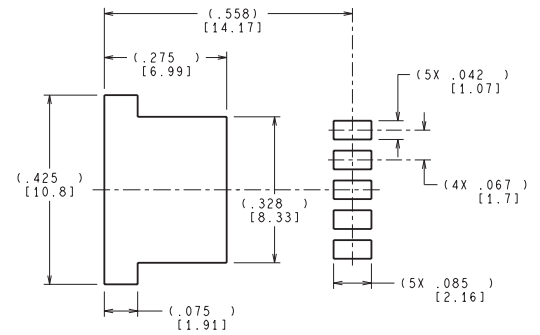
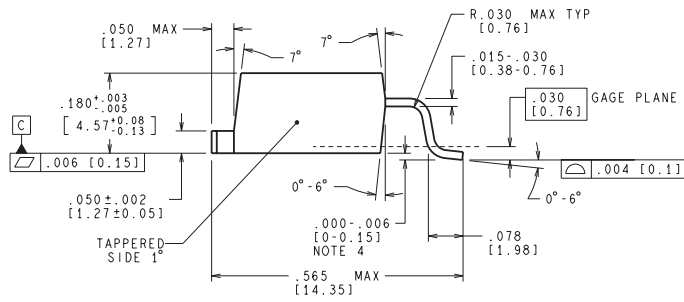
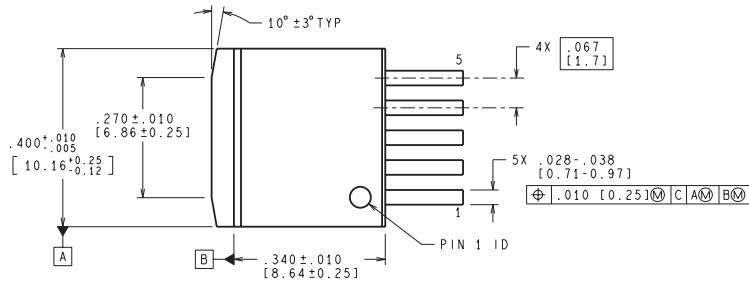

LAND PATTERN RECOMMENDATION

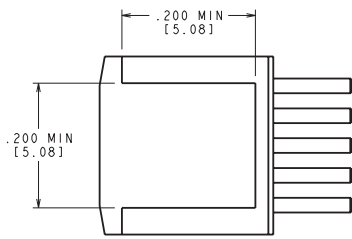

BOTTOM SIDE OF PACKAGE

CONTROLLING DIMENSION IS INCH
VALUES IN [] ARE MILLIMETERS
DIMENSIONS IN () FOR REFERENCE ONLY

TS5B (Rev D)

NEB0005B

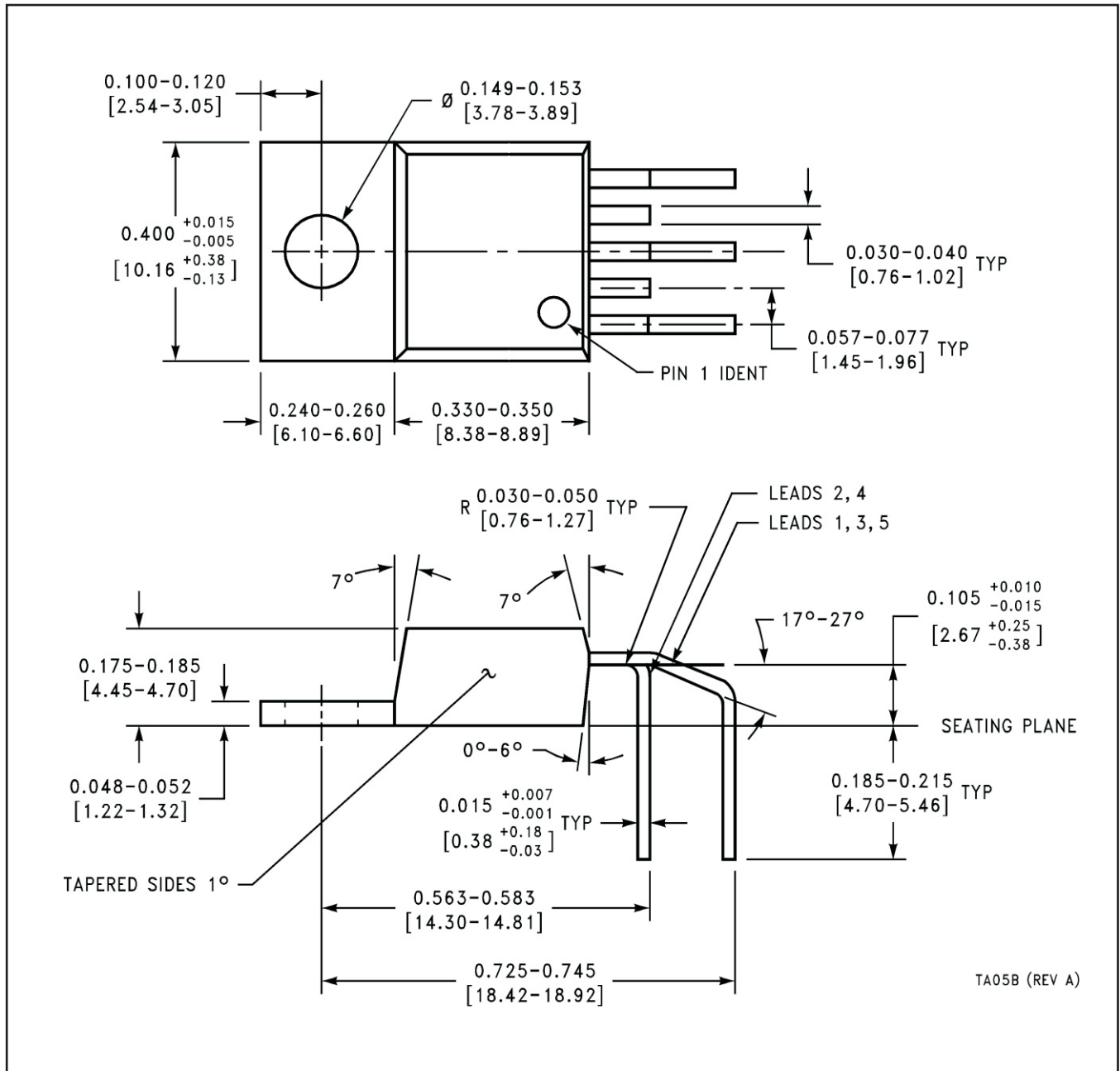

KC (R-PSFM-T5)

PLASTIC FLANGE-MOUNT PACKAGE

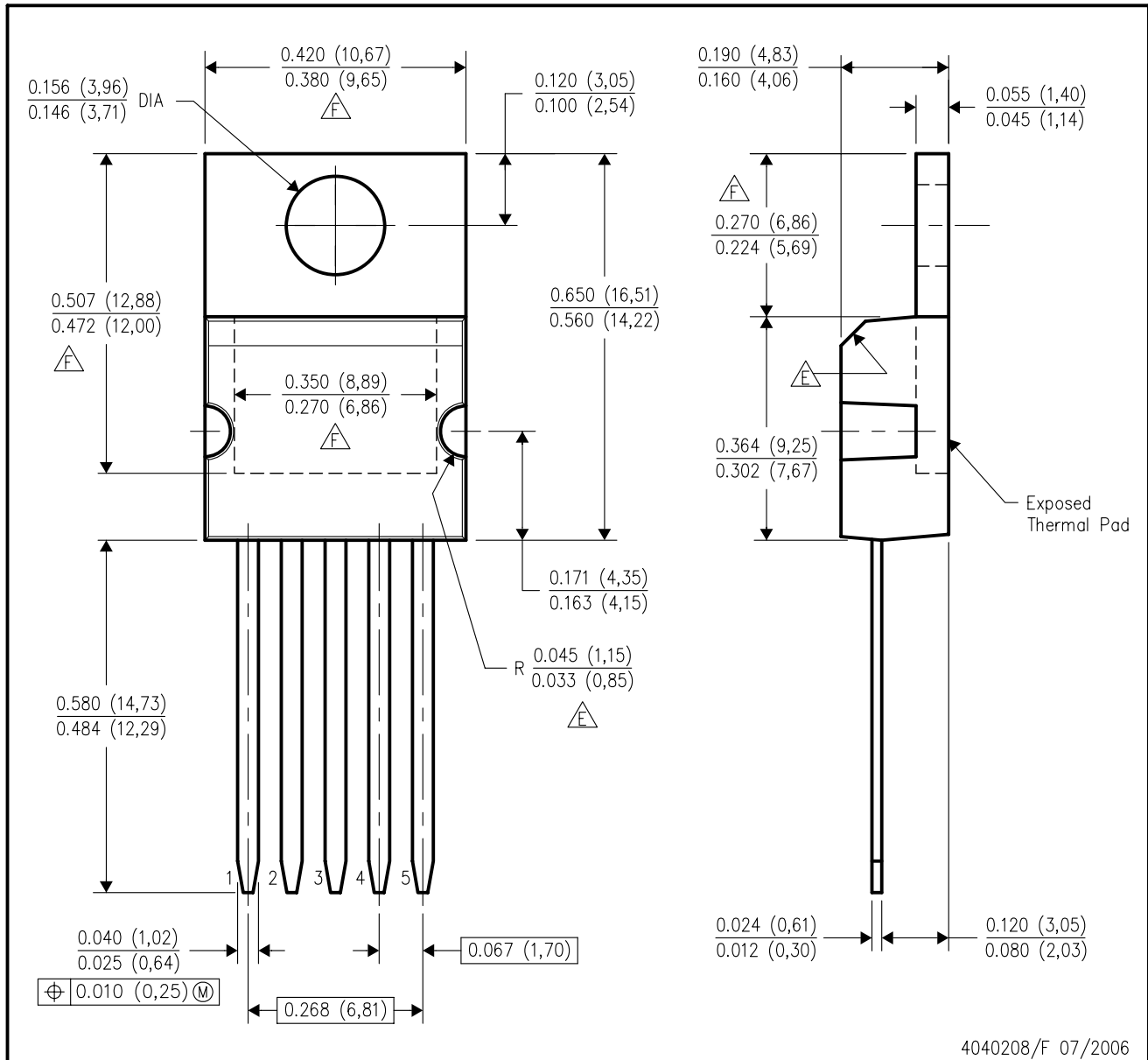

- NOTES:
- All linear dimensions are in inches (millimeters).
 - This drawing is subject to change without notice.
 - All lead dimensions apply before solder dip.
 - The center lead is in electrical contact with the mounting tab.
- $\triangle F$ These features are optional.
- $\triangle E$ Thermal pad contour optional within these dimensions.