

LM135A/LM235A/LM335A Precision Temperature Sensors

Check for Samples: [LM135](#), [LM135A](#), [LM235](#), [LM235A](#), [LM335](#), [LM335A](#)

FEATURES

- Directly Calibrated in °Kelvin
- 1°C Initial Accuracy Available
- Operates from 400 μ A to 5 mA
- Less than 1 Ω Dynamic Impedance
- Easily Calibrated
- Wide Operating Temperature Range
- 200°C Overrange
- Low Cost

DESCRIPTION

The LM135 series are precision, easily-calibrated, integrated circuit temperature sensors. Operating as a 2-terminal zener, the LM135 has a breakdown voltage directly proportional to absolute temperature at +10 mV/°K. With less than 1 Ω dynamic impedance the device operates over a current range of 400 μ A to 5 mA with virtually no change in performance. When calibrated at 25°C the LM135 has typically less than 1°C error over a 100°C temperature range. Unlike other sensors the LM135 has a linear output.

Applications for the LM135 include almost any type of temperature sensing over a -55°C to 150°C temperature range. The low impedance and linear output make interfacing to readout or control circuitry especially easy.

The LM135 operates over a -55°C to 150°C temperature range while the LM235 operates over a -40°C to 125°C temperature range. The LM335 operates from -40°C to 100°C. The LM135/LM235/LM335 are available packaged in hermetic TO transistor packages while the LM335 is also available in plastic TO-92 packages.

Schematic Diagram

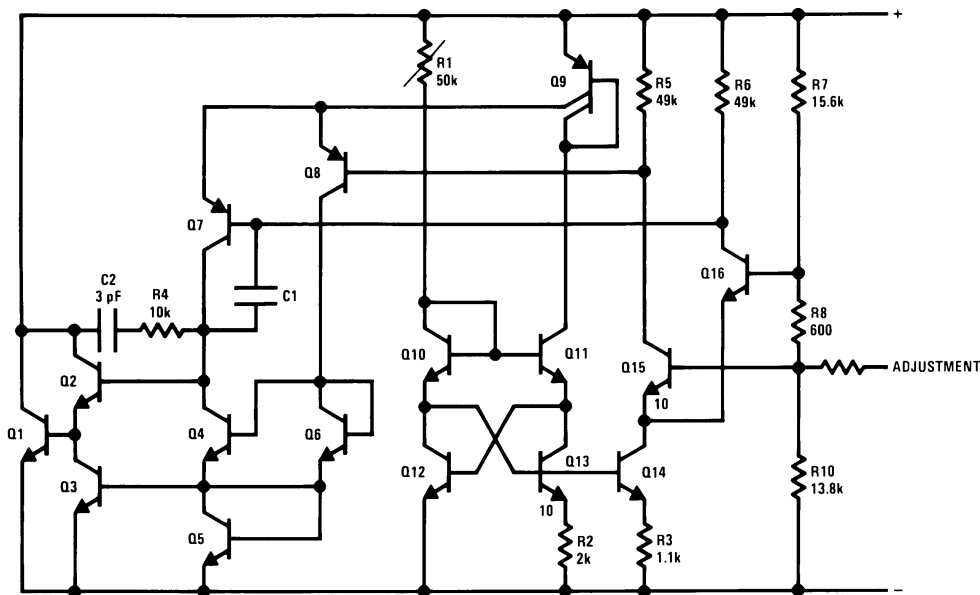

These devices have limited built-in ESD protection. The leads should be shorted together or the device placed in conductive foam during storage or handling to prevent electrostatic damage to the MOS gates.

LM135, LM135A, LM235, LM235A, LM335, LM335A

SNIS160D – MAY 1999 – REVISED MARCH 2013

Absolute Maximum Ratings⁽¹⁾⁽²⁾

Reverse Current		15 mA
Forward Current		10 mA
Storage Temperature		
8-Pin SOIC Package		-65°C to 150°C
TO-92 Package		-60°C to 150°C
TO Package		-60°C to 180°C
Specified Operating Temp. Range		
	Continuous	Intermittent⁽³⁾
LM135, LM135A	-55°C to 150°C	150°C to 200°C
LM235, LM235A	-40°C to 125°C	125°C to 150°C
LM335, LM335A	-40°C to 100°C	100°C to 125°C
Lead Temp. (Soldering, 10 seconds)		
8-Pin SOIC Package:		300°C
Vapor Phase (60 seconds):		215°C
Infrared (15 seconds):		220°C
TO-92 Package:		260°C
TO Package:		300°C

- (1) Refer to RETS135H for military specifications.
 (2) If Military/Aerospace specified devices are required, please contact the TI Sales Office/Distributors for availability and specifications.
 (3) Continuous operation at these temperatures for 10,000 hours for NDV package and 5,000 hours for LP package may decrease life expectancy of the device.

Temperature Accuracy⁽¹⁾

LM135/LM235, LM135A/LM235A

Parameter	Conditions	LM135A/LM235A			LM135/LM235			Units
		Min	Typ	Max	Min	Typ	Max	
Operating Output Voltage	$T_C = 25^\circ\text{C}, I_R = 1 \text{ mA}$	2.97	2.98	2.99	2.95	2.98	3.01	V
Uncalibrated Temperature Error	$T_C = 25^\circ\text{C}, I_R = 1 \text{ mA}$		0.5	1		1	3	°C
Uncalibrated Temperature Error	$T_{\text{MIN}} \leq T_C \leq T_{\text{MAX}}, I_R = 1 \text{ mA}$		1.3	2.7		2	5	°C
Temperature Error with 25°C	$T_{\text{MIN}} \leq T_C \leq T_{\text{MAX}}, I_R = 1 \text{ mA}$		0.3	1		0.5	1.5	°C
Calibration								
Calibrated Error at Extended Temperatures	$T_C = T_{\text{MAX}}$ (Intermittent)		2			2		°C
Non-Linearity	$I_R = 1 \text{ mA}$		0.3	0.5		0.3	1	°C

- (1) Accuracy measurements are made in a well-stirred oil bath. For other conditions, self heating must be considered.

Temperature Accuracy⁽¹⁾

LM335, LM335A

Parameter	Conditions	LM335A			LM335			Units
		Min	Typ	Max	Min	Typ	Max	
Operating Output Voltage	$T_C = 25^\circ\text{C}, I_R = 1 \text{ mA}$	2.95	2.98	3.01	2.92	2.98	3.04	V
Uncalibrated Temperature Error	$T_C = 25^\circ\text{C}, I_R = 1 \text{ mA}$		1	3		2	6	°C
Uncalibrated Temperature Error	$T_{\text{MIN}} \leq T_C \leq T_{\text{MAX}}, I_R = 1 \text{ mA}$		2	5		4	9	°C
Temperature Error with 25°C	$T_{\text{MIN}} \leq T_C \leq T_{\text{MAX}}, I_R = 1 \text{ mA}$		0.5	1		1	2	°C
Calibration								
Calibrated Error at Extended Temperatures	$T_C = T_{\text{MAX}}$ (Intermittent)		2			2		°C
Non-Linearity	$I_R = 1 \text{ mA}$		0.3	1.5		0.3	1.5	°C

- (1) Accuracy measurements are made in a well-stirred oil bath. For other conditions, self heating must be considered.

Electrical Characteristics⁽¹⁾

Parameter	Conditions	LM135/LM235			LM335			Units
		LM135A/LM235A			LM335A			
		Min	Typ	Max	Min	Typ	Max	
Operating Output Voltage	$400 \mu A \leq I_R \leq 5 \text{ mA}$		2.5	10		3	14	mV
Change with Current	At Constant Temperature							
Dynamic Impedance	$I_R = 1 \text{ mA}$		0.5			0.6		Ω
Output Voltage Temperature			+10			+10		mV/°C
Coefficient								
Time Constant	Still Air		80			80		sec
	100 ft/Min Air		10			10		sec
	Stirred Oil		1			1		sec
Time Stability	$T_C = 125^\circ\text{C}$		0.2			0.2		°C/khr

(1) Accuracy measurements are made in a well-stirred oil bath. For other conditions, self heating must be considered.

Thermal Resistance	8-Pin SOIC	TO-92	TO
θ_{JA} (Junction to Ambient)	165°C/W	202°C/W	400°C/W
θ_{JC} (Junction to Case)	N/A	170°C/W	N/A

CONNECTION DIAGRAMS

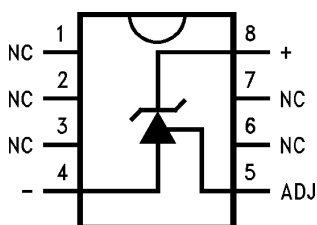

Figure 1. 8-Pin SOIC Surface Mount Package Top View Package Number M08A

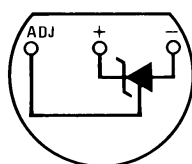

Figure 2. TO-92 Plastic Package Bottom View Package Number Z03A

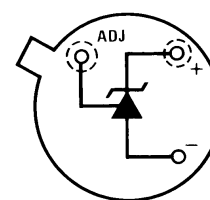

Figure 3. TO Metal Can Package⁽¹⁾ Bottom View Package Number H03H

(1) Case is connected to negative pin.

Typical Performance Characteristics

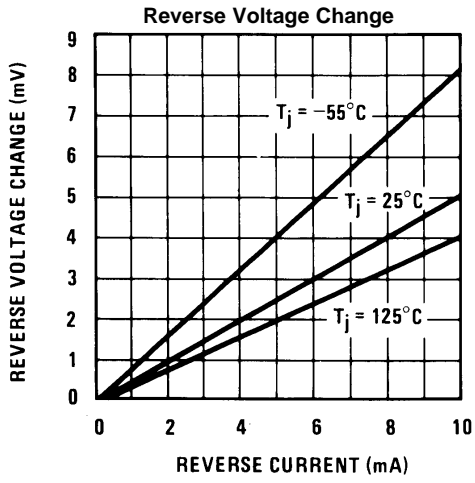

Figure 4.

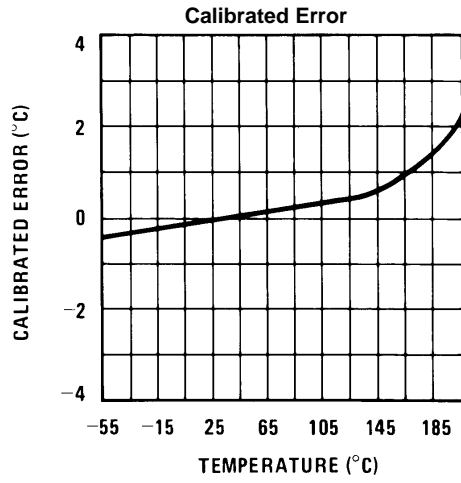

Figure 5.

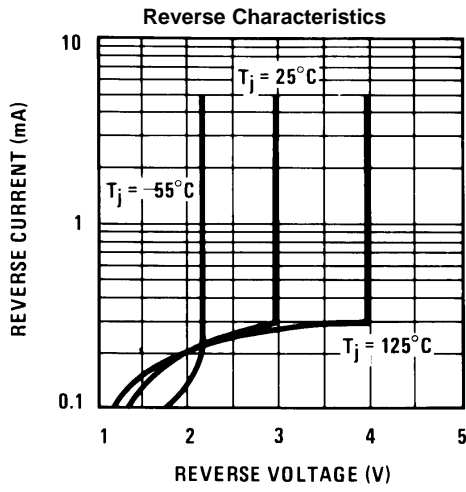

Figure 6.

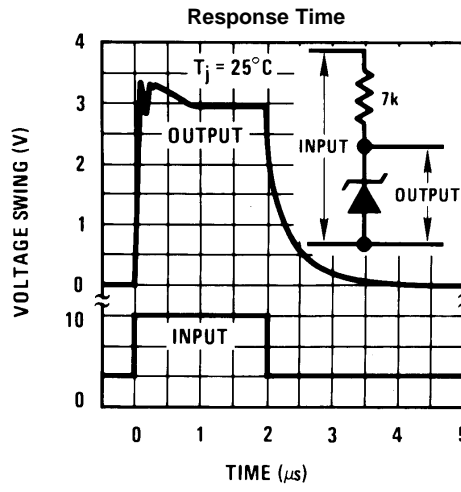

Figure 7.

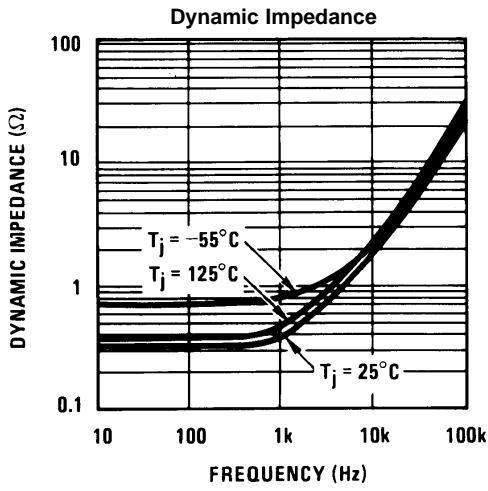

Figure 8.

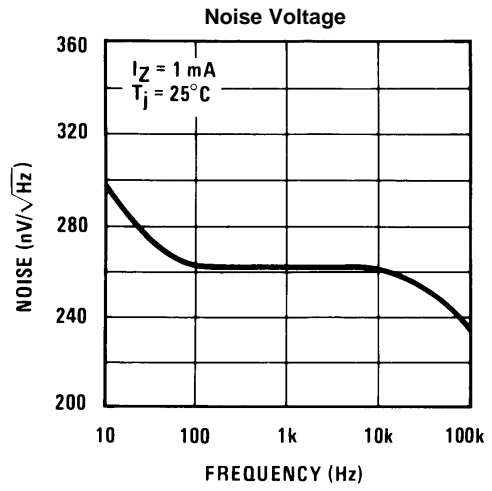

Figure 9.

Typical Performance Characteristics (continued)

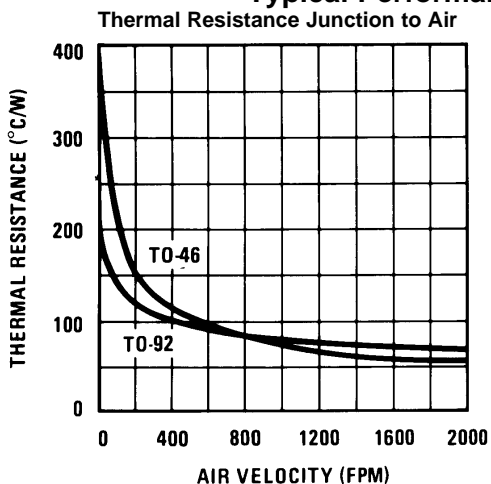

Figure 10.

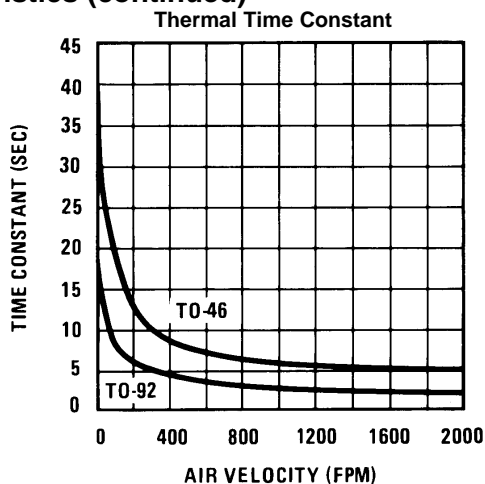

Figure 11.

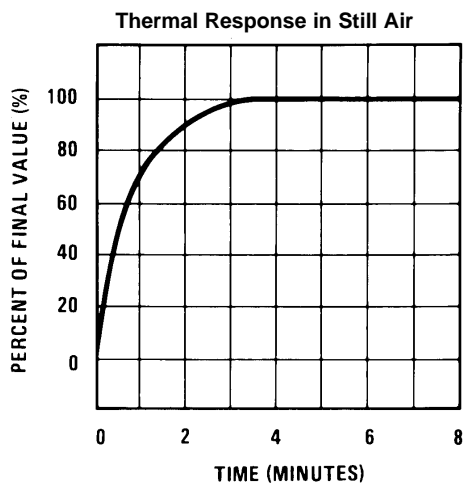

Figure 12.

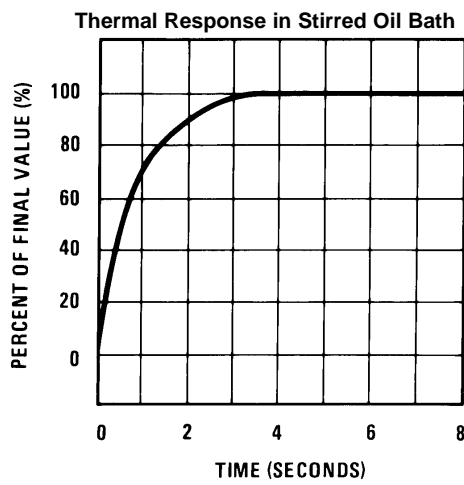

Figure 13.

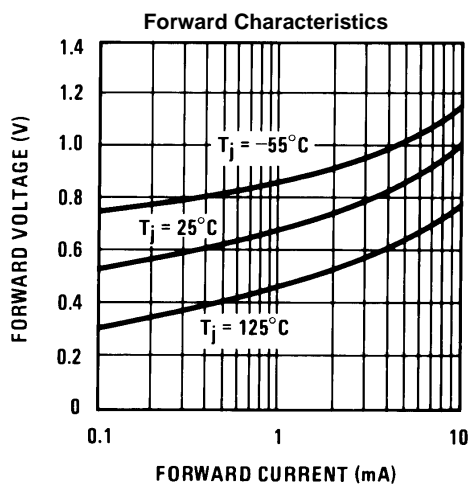

Figure 14.

APPLICATION INFORMATION

CALIBRATING THE LM135

Included on the LM135 chip is an easy method of calibrating the device for higher accuracies. A pot connected across the LM135 with the arm tied to the adjustment terminal allows a 1-point calibration of the sensor that corrects for inaccuracy over the full temperature range.

This single point calibration works because the output of the LM135 is proportional to absolute temperature with the extrapolated output of sensor going to 0V output at 0°K (-273.15°C). Errors in output voltage versus temperature are only slope (or scale factor) errors so a slope calibration at one temperature corrects at all temperatures.

The output of the device (calibrated or uncalibrated) can be expressed as:

$$V_{OUT_T} = V_{OUT_{T_0}} \times \frac{T}{T_0} \tag{1}$$

where T is the unknown temperature and T₀ is a reference temperature, both expressed in degrees Kelvin. By calibrating the output to read correctly at one temperature the output at all temperatures is correct. Nominally the output is calibrated at 10 mV/°K.

To insure good sensing accuracy several precautions must be taken. Like any temperature sensing device, self heating can reduce accuracy. The LM135 should be operated at the lowest current suitable for the application. Sufficient current, of course, must be available to drive both the sensor and the calibration pot at the maximum operating temperature as well as any external loads.

If the sensor is used in an ambient where the thermal resistance is constant, self heating errors can be calibrated out. This is possible if the device is run with a temperature stable current. Heating will then be proportional to zener voltage and therefore temperature. This makes the self heating error proportional to absolute temperature the same as scale factor errors.

WATERPROOFING SENSORS

Meltable inner core heat shrinkable tubing such as manufactured by Raychem can be used to make low-cost waterproof sensors. The LM335 is inserted into the tubing about ½" from the end and the tubing heated above the melting point of the core. The unfilled ½" end melts and provides a seal over the device.

Typical Applications

Figure 15. Basic Temperature Sensor

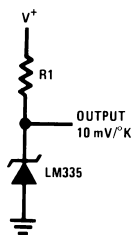
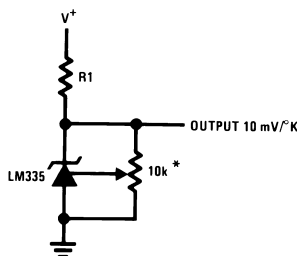

Figure 16. Calibrated Sensor



*Calibrate for 2.982V at 25°C

Figure 17. Wide Operating Supply

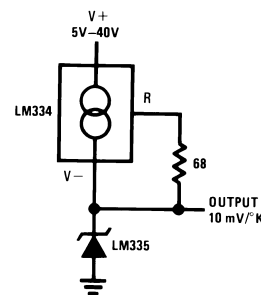

Figure 18. Minimum Temperature Sensing

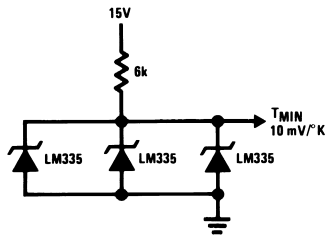
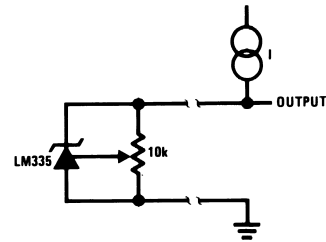
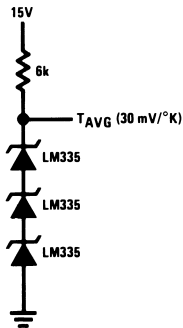

Figure 20. Remote Temperature Sensing



Wire length for 1°C error due to wire drop

Figure 19. Average Temperature Sensing



AWG	$I_R = 1 \text{ mA}$	$I_R = 0.5 \text{ mA}^{(1)}$
	FEET	FEET
14	4000	8000
16	2500	5000
18	1600	3200
20	1000	2000
22	625	1250
24	400	800

(1) For $I_R = 0.5 \text{ mA}$, the trim pot must be deleted.

Figure 21. Isolated Temperature Sensor

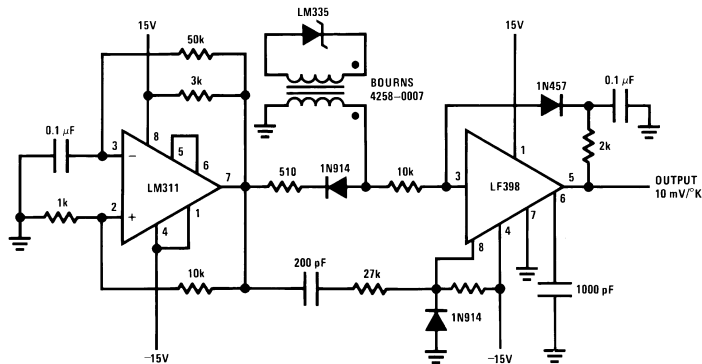

Figure 22. Simple Temperature Controller

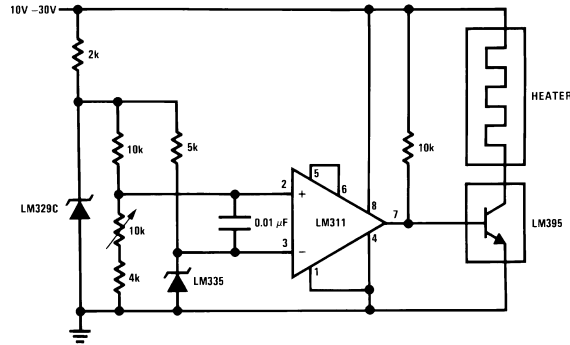

Figure 23. Simple Temperature Control

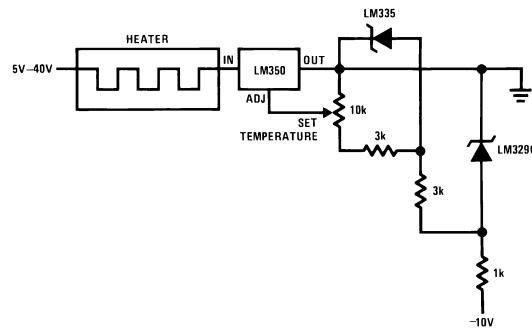
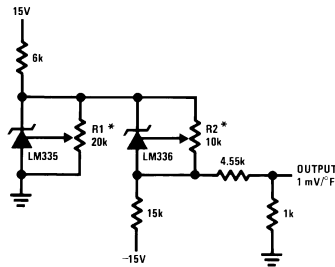
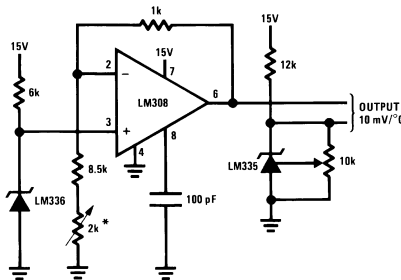

Figure 24. Ground Referred Fahrenheit Thermometer



*Adjust R2 for 2.554V across LM336.
Adjust R1 for correct output.

Figure 25. Centigrade Thermometer



*Adjust for 2.7315V at output of LM308

Figure 26. Fahrenheit Thermometer

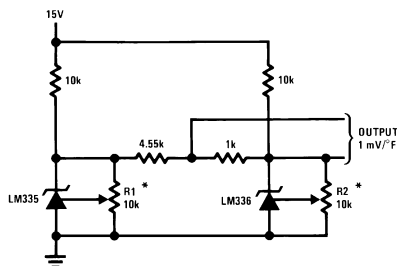

*To calibrate adjust R2 for 2.554V across LM336.
Adjust R1 for correct output.

Figure 27. THERMOCOUPLE COLD JUNCTION COMPENSATION

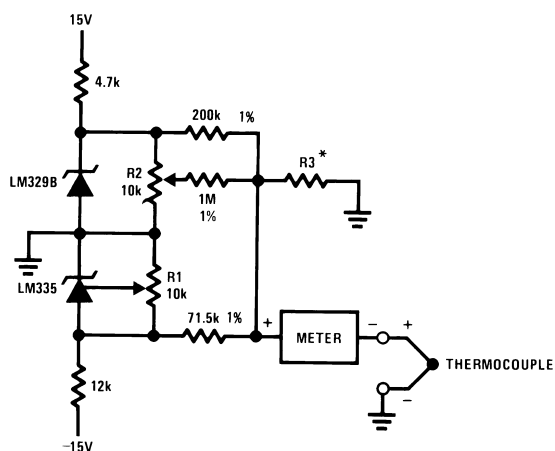

Compensation for Grounded Thermocouple

*Select R3 for proper thermocouple type

THERMO-COUPLE	R3 ($\pm 1\%$)	SEEBECK COEFFICIENT
J	377 Ω	52.3 $\mu\text{V}/^\circ\text{C}$
T	308 Ω	42.8 $\mu\text{V}/^\circ\text{C}$
K	293 Ω	40.8 $\mu\text{V}/^\circ\text{C}$
S	45.8 Ω	6.4 $\mu\text{V}/^\circ\text{C}$

Adjustments: Compensates for both sensor and resistor tolerances

1. Short LM329B
2. Adjust R1 for Seebeck Coefficient times ambient temperature (in degrees K) across R3.
3. Short LM335 and adjust R2 for voltage across R3 corresponding to thermocouple type.

J 14.32 mV K 11.17 mV
T 11.79 mV S 1.768 mV

Figure 28. Single Power Supply Cold Junction Compensation

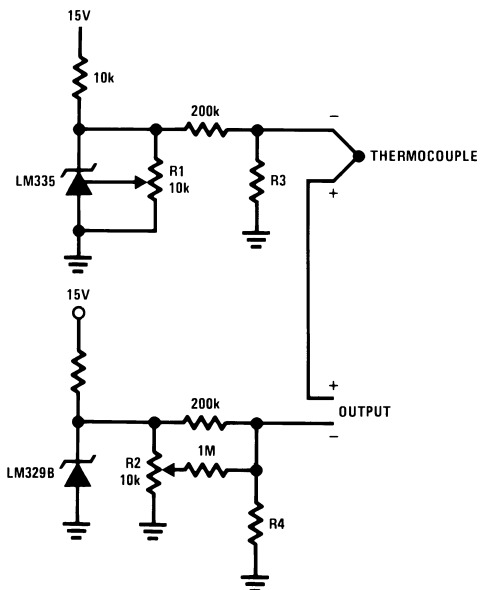

*Select R3 and R4 for thermocouple type

THERMO-COUPLE	R3	R4	SEEBECK COEFFICIENT
J	1.05K	385Ω	52.3 μV/°C
T	856Ω	315Ω	42.8 μV/°C
K	816Ω	300Ω	40.8 μV/°C
S	128Ω	46.3Ω	6.4 μV/°C

Adjustments:

- Adjust R1 for the voltage across R3 equal to the Seebeck Coefficient times ambient temperature in degrees Kelvin.
- Adjust R2 for voltage across R4 corresponding to thermocouple.

J	14.32 mV
T	11.79 mV
K	11.17 mV
S	1.768 mV

Figure 29. Centigrade Calibrated Thermocouple Thermometer

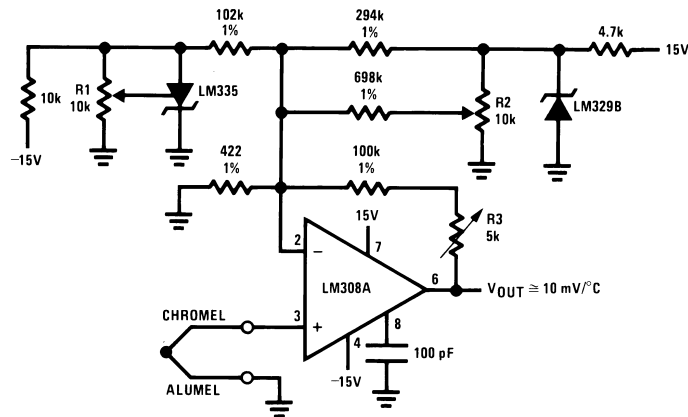

Terminate thermocouple reference junction in close proximity to LM335.

Adjustments:

1. Apply signal in place of thermocouple and adjust R3 for a gain of 245.7.
2. Short non-inverting input of LM308A and output of LM329B to ground.
3. Adjust R1 so that $V_{OUT} = 2.982V @ 25^{\circ}C$.
4. Remove short across LM329B and adjust R2 so that $V_{OUT} = 246 mV @ 25^{\circ}C$.
5. Remove short across thermocouple.

Figure 30. Fast Charger for Nickel-Cadmium Batteries

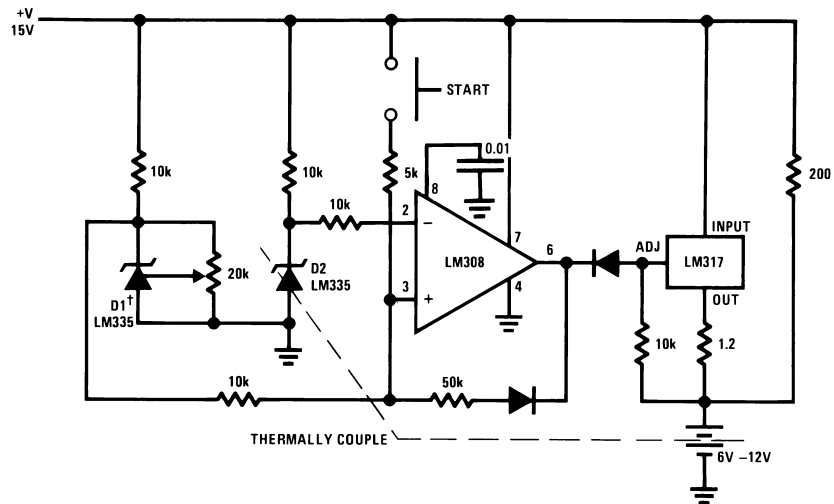

†Adjust D1 to 50 mV greater V_Z than D2.
 Charge terminates on 5°C temperature rise. Couple D2 to battery.

Figure 31. Differential Temperature Sensor

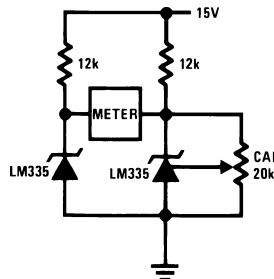

Figure 32. Differential Temperature Sensor

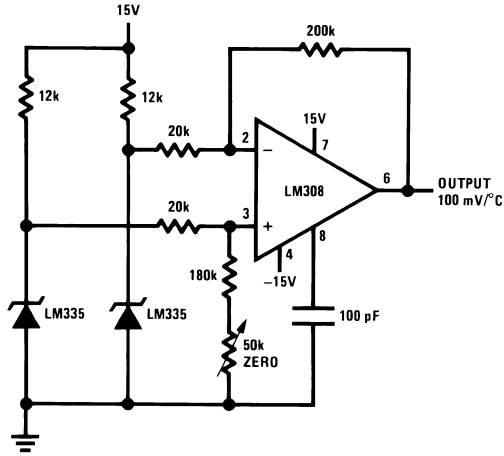
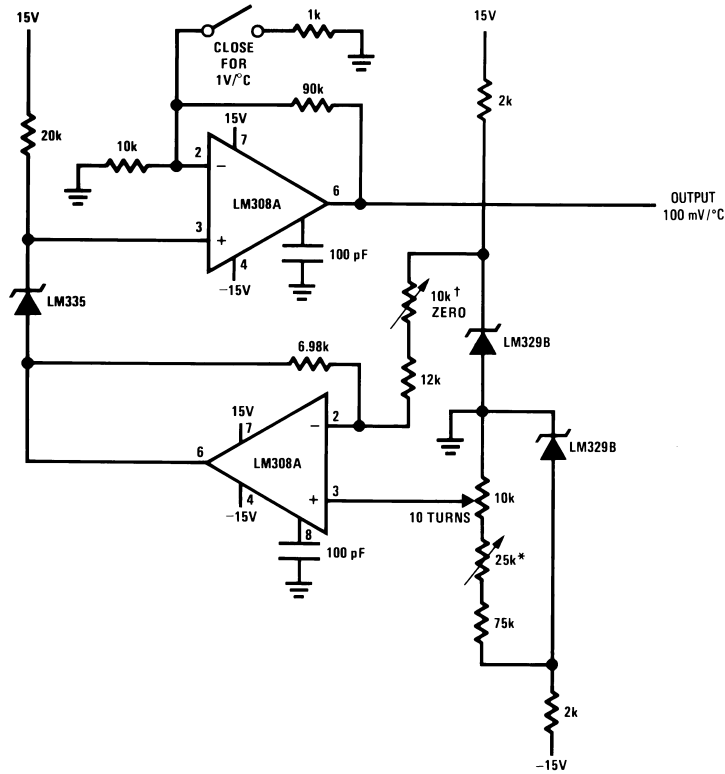

Figure 33. Variable Offset Thermometer†



†Adjust for zero with sensor at 0°C and 10T pot set at 0°C
 *Adjust for zero output with 10T pot set at 100°C and sensor at 100°C
 ‡Output reads difference between temperature and dial setting of 10T pot

Figure 34. Ground Referred Centigrade Thermometer

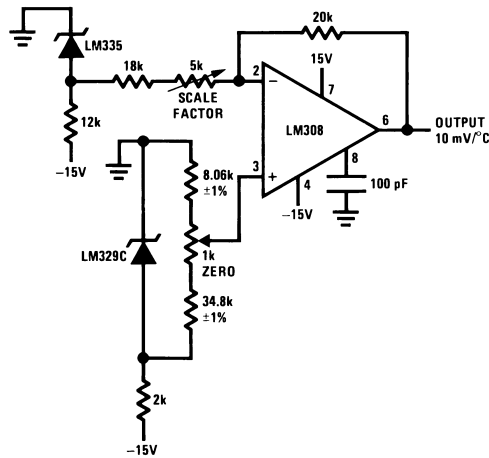
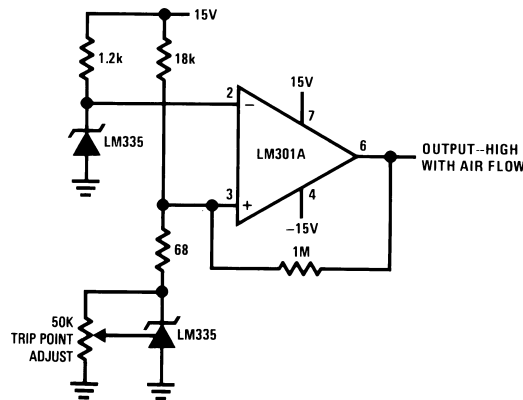

Figure 35. Air Flow Detector*



*Self heating is used to detect air flow

DEFINITION OF TERMS

Operating Output Voltage: The voltage appearing across the positive and negative terminals of the device at specified conditions of operating temperature and current.

Uncalibrated Temperature Error: The error between the operating output voltage at 10 mV/°K and case temperature at specified conditions of current and case temperature.

Calibrated Temperature Error: The error between operating output voltage and case temperature at 10 mV/°K over a temperature range at a specified operating current with the 25°C error adjusted to zero.

HISTORY

Changes from Revision C (March 2013) to Revision D

Page

-
- Changed layout of National Data Sheet to TI format [13](#)
-

PACKAGE OPTION ADDENDUM

PACKAGING INFORMATION

Orderable Device	Status (1)	Package Type	Package Drawing	Pins	Package Qty	Eco Plan (2)	Lead/Ball Finish	MSL Peak Temp (3)	Op Temp (°C)	Device Marking (4/5)	Samples
LM135AH	ACTIVE	TO	NDV	3	1000	TBD	Call TI	Call TI	-55 to 150	LM135AH	Samples
LM135AH/NOPB	ACTIVE	TO	NDV	3	1000	Green (RoHS & no Sb/Br)	POST-PLATE	Level-1-NA-UNLIM	-55 to 150	LM135AH	Samples
LM135H	ACTIVE	TO	NDV	3	1000	TBD	Call TI	Call TI	-55 to 150	LM135H	Samples
LM135H/NOPB	ACTIVE	TO	NDV	3	1000	Green (RoHS & no Sb/Br)	POST-PLATE	Level-1-NA-UNLIM	-55 to 150	LM135H	Samples
LM235AH	ACTIVE	TO	NDV	3	1000	TBD	Call TI	Call TI	-40 to 125	LM235AH	Samples
LM235AH/NOPB	ACTIVE	TO	NDV	3	1000	Green (RoHS & no Sb/Br)	POST-PLATE	Level-1-NA-UNLIM	-40 to 125	LM235AH	Samples
LM235H	ACTIVE	TO	NDV	3	1000	TBD	Call TI	Call TI	-40 to 125	LM235H	Samples
LM235H/NOPB	ACTIVE	TO	NDV	3	1000	Green (RoHS & no Sb/Br)	POST-PLATE	Level-1-NA-UNLIM	-40 to 125	LM235H	Samples
LM335A MWC	ACTIVE	WAFERSALE	YS	0	1	Green (RoHS & no Sb/Br)	Call TI	Level-1-NA-UNLIM			Samples
LM335AH	ACTIVE	TO	NDV	3	1000	TBD	Call TI	Call TI	-40 to 100	LM335AH	Samples
LM335AH/NOPB	ACTIVE	TO	NDV	3	1000	Green (RoHS & no Sb/Br)	POST-PLATE	Level-1-NA-UNLIM	-40 to 100	LM335AH	Samples
LM335AM	ACTIVE	SOIC	D	8	95	TBD	Call TI	Call TI	-40 to 100	LM335 AM	Samples
LM335AM/NOPB	ACTIVE	SOIC	D	8	95	Green (RoHS & no Sb/Br)	CU SN	Level-1-260C-UNLIM	-40 to 100	LM335 AM	Samples
LM335AMX	ACTIVE	SOIC	D	8	2500	TBD	Call TI	Call TI	-40 to 100	LM335 AM	Samples
LM335AMX/NOPB	ACTIVE	SOIC	D	8	2500	Green (RoHS & no Sb/Br)	CU SN	Level-1-260C-UNLIM	-40 to 100	LM335 AM	Samples
LM335AZ/LFT1	ACTIVE	TO-92	LP	3	2000	Green (RoHS & no Sb/Br)	SN	Level-1-NA-UNLIM		LM335 AZ	Samples
LM335AZ/NOPB	ACTIVE	TO-92	LP	3	1800	Green (RoHS & no Sb/Br)	SNCU	Level-1-NA-UNLIM	-40 to 100	LM335 AZ	Samples
LM335H	ACTIVE	TO	NDV	3	1000	TBD	Call TI	Call TI	-40 to 100	LM335H	

PACKAGE OPTION ADDENDUM

Orderable Device	Status (1)	Package Type	Package Drawing	Pins	Package Qty	Eco Plan (2)	Lead/Ball Finish	MSL Peak Temp (3)	Op Temp (°C)	Device Marking (4/5)	Samples
LM335H/NOPB	ACTIVE	TO	NDV	3	1000	Green (RoHS & no Sb/Br)	POST-PLATE	Level-1-NA-UNLIM	-40 to 100	LM335H	Samples
LM335M	ACTIVE	SOIC	D	8	95	TBD	Call TI	Call TI	-40 to 100	LM335 M	Samples
LM335M/NOPB	ACTIVE	SOIC	D	8	95	Green (RoHS & no Sb/Br)	CU SN	Level-1-260C-UNLIM	-40 to 100	LM335 M	Samples
LM335MX	ACTIVE	SOIC	D	8	2500	TBD	Call TI	Call TI	-40 to 100	LM335 M	Samples
LM335MX/NOPB	ACTIVE	SOIC	D	8	2500	Green (RoHS & no Sb/Br)	CU SN	Level-1-260C-UNLIM	-40 to 100	LM335 M	Samples
LM335Z/LFT7	ACTIVE	TO-92	LP	3	2000	Green (RoHS & no Sb/Br)	SNCU	Level-1-NA-UNLIM		LM335 Z	Samples
LM335Z/NOPB	ACTIVE	TO-92	LP	3	1800	Green (RoHS & no Sb/Br)	SNCU	Level-1-NA-UNLIM	-40 to 100	LM335 Z	Samples

PACKAGE MATERIALS INFORMATION

TAPE AND REEL INFORMATION

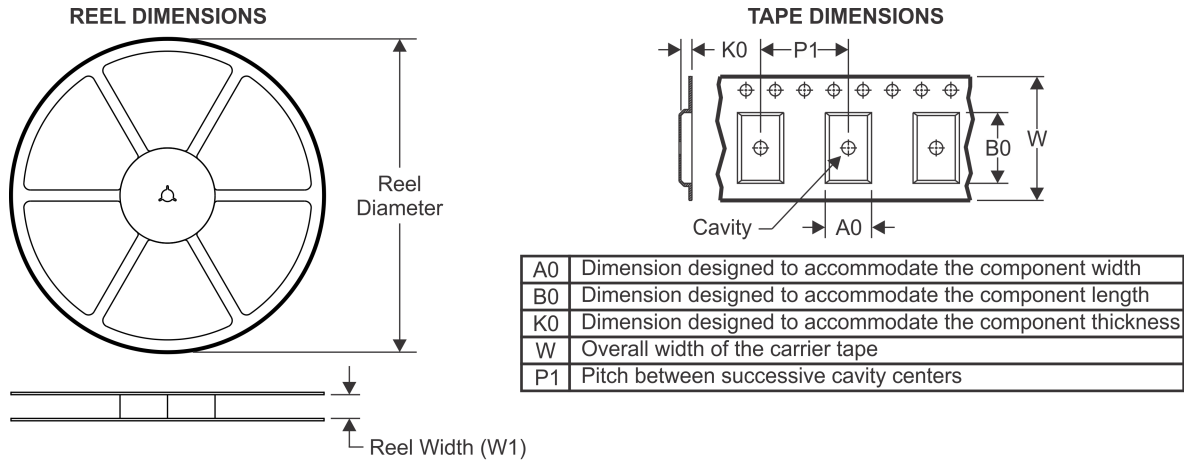

QUADRANT ASSIGNMENTS FOR PIN 1 ORIENTATION IN TAPE

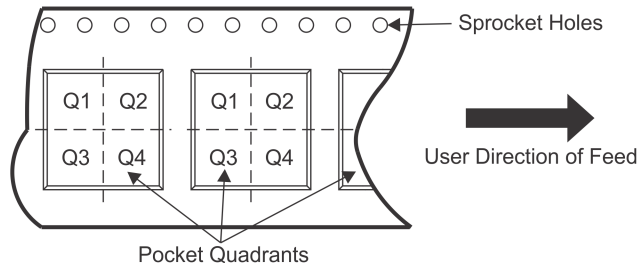

*All dimensions are nominal

Device	Package Type	Package Drawing	Pins	SPQ	Reel Diameter (mm)	Reel Width W1 (mm)	A0 (mm)	B0 (mm)	K0 (mm)	P1 (mm)	W (mm)	Pin1 Quadrant
LM335AMX	SOIC	D	8	2500	330.0	12.4	6.5	5.4	2.0	8.0	12.0	Q1
LM335AMX/NOPB	SOIC	D	8	2500	330.0	12.4	6.5	5.4	2.0	8.0	12.0	Q1
LM335MX	SOIC	D	8	2500	330.0	12.4	6.5	5.4	2.0	8.0	12.0	Q1
LM335MX/NOPB	SOIC	D	8	2500	330.0	12.4	6.5	5.4	2.0	8.0	12.0	Q1

PACKAGE MATERIALS INFORMATION

TAPE AND REEL BOX DIMENSIONS

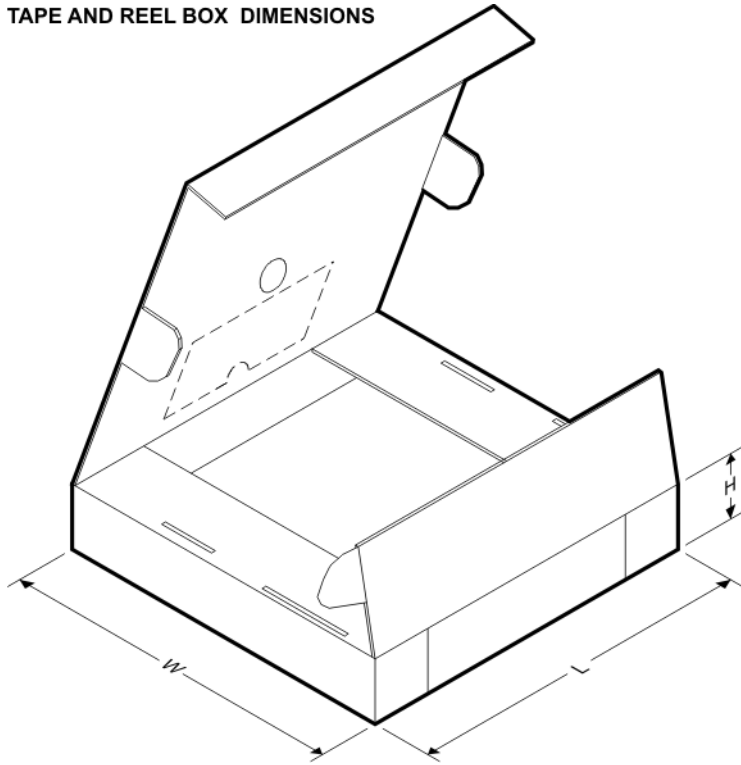

*All dimensions are nominal

Device	Package Type	Package Drawing	Pins	SPQ	Length (mm)	Width (mm)	Height (mm)
LM335AMX	SOIC	D	8	2500	367.0	367.0	35.0
LM335AMX/NOPB	SOIC	D	8	2500	367.0	367.0	35.0
LM335MX	SOIC	D	8	2500	367.0	367.0	35.0
LM335MX/NOPB	SOIC	D	8	2500	367.0	367.0	35.0

NDV0003H

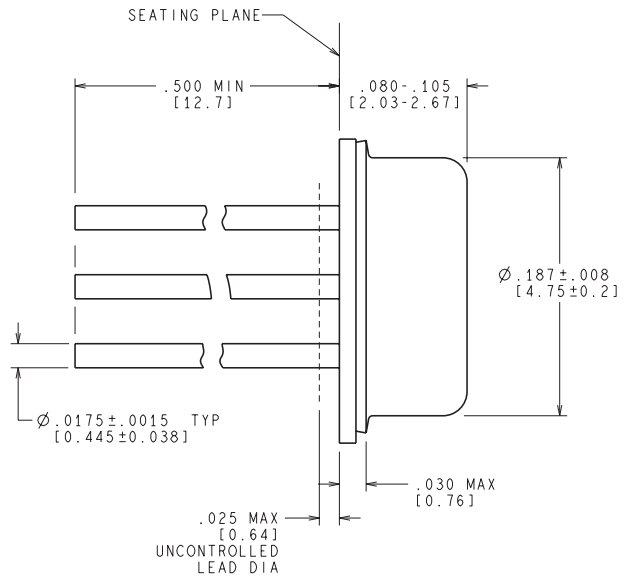
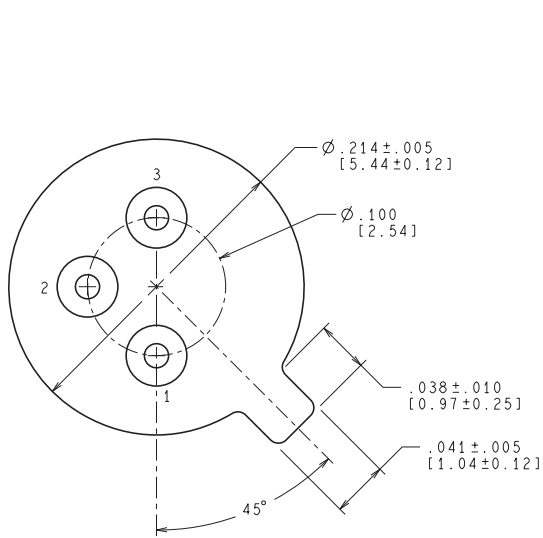

CONTROLLING DIMENSION IS INCH
VALUES IN [] ARE IN MILLIMETERS

H03H (Rev F)

MECHANICAL DATA

D (R-PDSO-G8)

PLASTIC SMALL OUTLINE



4040047-3/M 06/11

MECHANICAL DATA

LP (O-PBCY-W3)

PLASTIC CYLINDRICAL PACKAGE

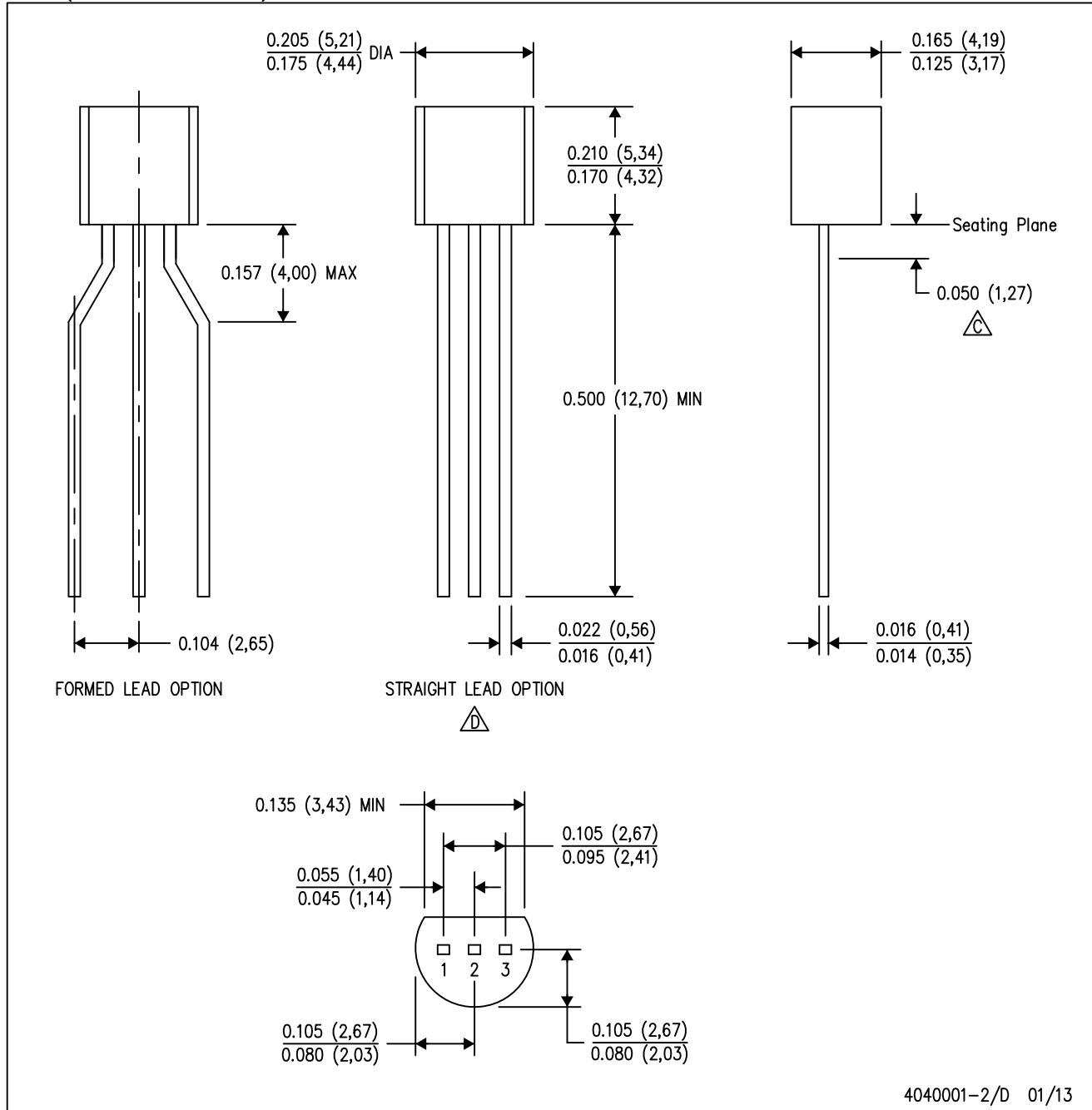

4040001-2/D 01/13

- NOTES:
- All linear dimensions are in inches (millimeters).
 - This drawing is subject to change without notice.
 - Lead dimensions are not controlled within this area.
 - Falls within JEDEC TO-226 Variation AA (TO-226 replaces TO-92).
 - Shipping Method:
 - Straight lead option available in either bulk pack or tape & reel.
 - Formed lead option available in tape & reel or ammo pack.
 - Specific products can be offered in limited combinations of shipping mediums and lead options.
 - Consult product folder for more information on available options.

MECHANICAL DATA

LP (O-PBCY-W3)

PLASTIC CYLINDRICAL PACKAGE

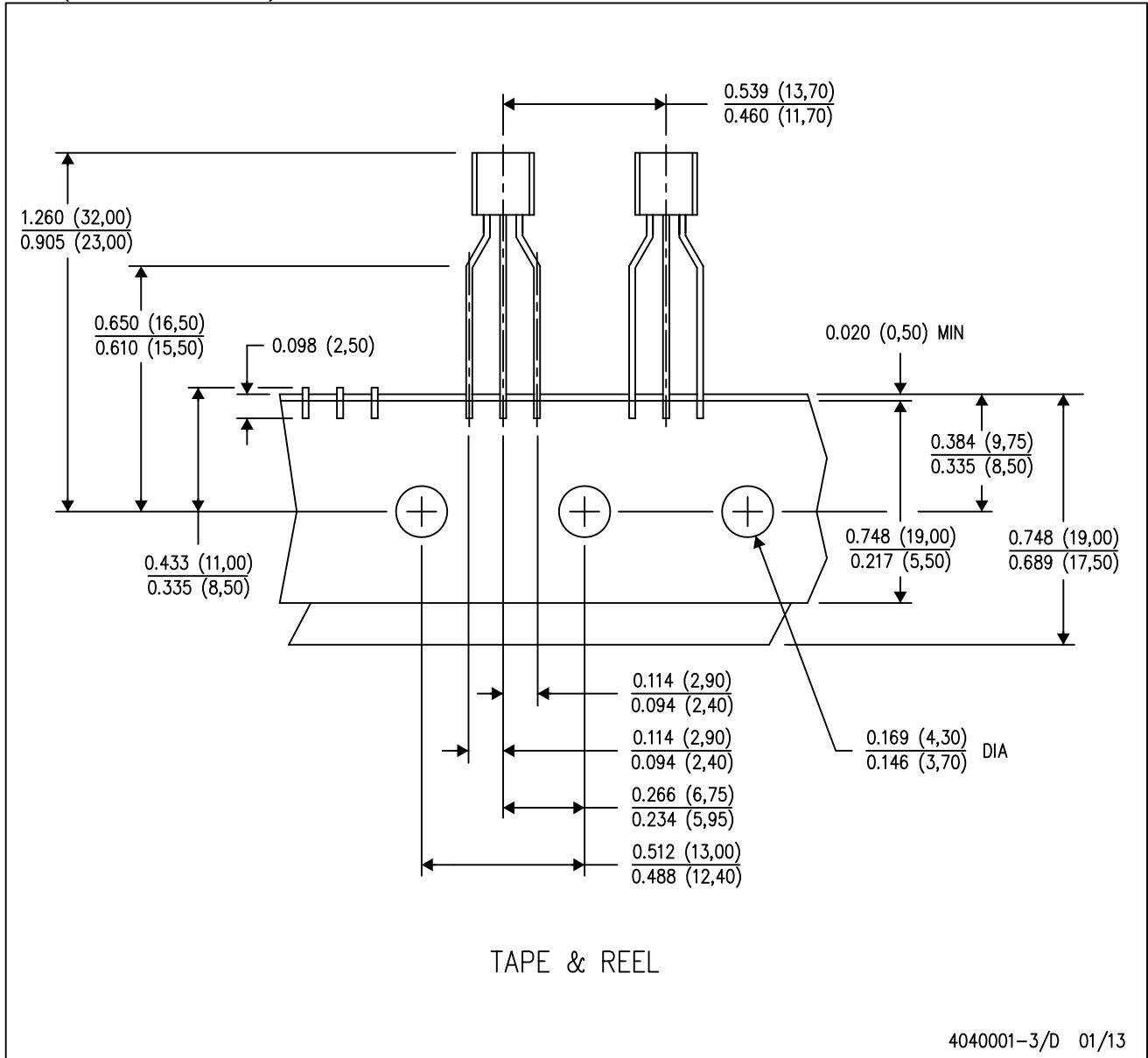

- NOTES:
- A. All linear dimensions are in inches (millimeters).
 - B. This drawing is subject to change without notice.
 - C. Tape and Reel information for the Formed Lead Option package.

