

December 2000

LM148/LM248/LM348

Quad 741 Op Amps

LM149

Wide Band Decompensated ($A_V (MIN) = 5$)

General Description

The LM148 series is a true quad 741. It consists of four independent, high gain, internally compensated, low power operational amplifiers which have been designed to provide functional characteristics identical to those of the familiar 741 operational amplifier. In addition the total supply current for all four amplifiers is comparable to the supply current of a single 741 type op amp. Other features include input offset currents and input bias current which are much less than those of a standard 741. Also, excellent isolation between amplifiers has been achieved by independently biasing each amplifier and using layout techniques which minimize thermal coupling. The LM149 series has the same features as the LM148 plus a gain bandwidth product of 4 MHz at a gain of 5 or greater.

The LM148 can be used anywhere multiple 741 or 1558 type amplifiers are being used and in applications where amplifier matching or high packing density is required. For lower power refer to LF444.

Features

- 741 op amp operating characteristics
- Class AB output stage—no crossover distortion
- Pin compatible with the LM124
- Overload protection for inputs and outputs
- Low supply current drain: 0.6 mA/Amplifier
- Low input offset voltage: 1 mV
- Low input offset current: 4 nA
- Low input bias current: 30 nA
- High degree of isolation between amplifiers: 120 dB
- Gain bandwidth product
 - LM148 (unity gain): 1.0 MHz
 - LM149 ($A_V \geq 5$): 4 MHz

Schematic Diagram

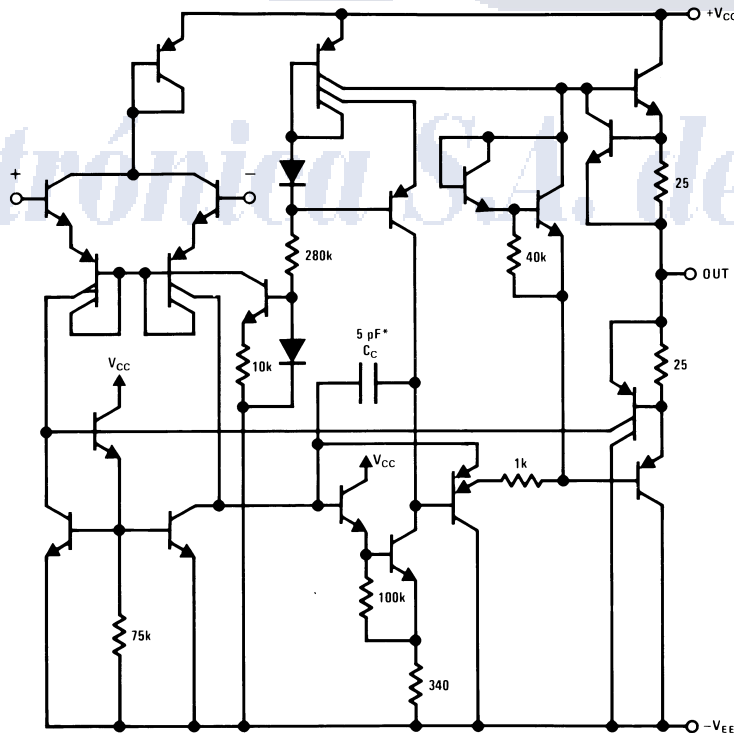

* 1 pF in the LM149

DS007786-1

LM148/LM149 Series Quad 741 Op Amp

Absolute Maximum Ratings (Note 4)

If Military/Aerospace specified devices are required, please contact the National Semiconductor Sales Office/Distributors for availability and specifications.

	LM148/LM149	LM248	LM348
Supply Voltage	±22V	±18V	±18V
Differential Input Voltage	±44V	±36V	±36V
Output Short Circuit Duration (Note 1)	Continuous	Continuous	Continuous
Power Dissipation (P_d at 25°C) and Thermal Resistance (θ_{jA}), (Note 2)			
Molded DIP (N) P_d	—	—	750 mW
θ_{jA}	—	—	100°C/W
Cavity DIP (J) P_d	1100 mW	800 mW	700 mW
θ_{jA}	110°C/W	110°C/W	110°C/W
Maximum Junction Temperature (T_{jMAX})	150°C	110°C	100°C
Operating Temperature Range	-55°C ≤ T_A ≤ +125°C	-25°C ≤ T_A ≤ +85°C	0°C ≤ T_A ≤ +70°C
Storage Temperature Range	-65°C to +150°C	-65°C to +150°C	-65°C to +150°C
Lead Temperature (Soldering, 10 sec.) Ceramic	300°C	300°C	300°C
Lead Temperature (Soldering, 10 sec.) Plastic			260°C
Soldering Information			
Dual-In-Line Package			
Soldering (10 seconds)	260°C	260°C	260°C
Small Outline Package			
Vapor Phase (60 seconds)	215°C	215°C	215°C
Infrared (15 seconds)	220°C	220°C	220°C
See AN-450 "Surface Mounting Methods and Their Effect on Product Reliability" for other methods of soldering surface mount devices.			
ESD tolerance (Note 5)	500V	500V	500V

Electrical Characteristics

(Note 3)

Parameter	Conditions	LM148/LM149			LM248			LM348			Units
		Min	Typ	Max	Min	Typ	Max	Min	Typ	Max	
Input Offset Voltage	$T_A = 25^\circ\text{C}$, $R_S \leq 10\text{ k}\Omega$		1.0	5.0		1.0	6.0		1.0	6.0	mV
Input Offset Current	$T_A = 25^\circ\text{C}$		4	25		4	50		4	50	nA
Input Bias Current	$T_A = 25^\circ\text{C}$		30	100		30	200		30	200	nA
Input Resistance	$T_A = 25^\circ\text{C}$	0.8	2.5		0.8	2.5		0.8	2.5		MΩ
Supply Current All Amplifiers	$T_A = 25^\circ\text{C}$, $V_S = \pm 15\text{V}$		2.4	3.6		2.4	4.5		2.4	4.5	mA
Large Signal Voltage Gain	$T_A = 25^\circ\text{C}$, $V_S = \pm 15\text{V}$ $V_{OUT} = \pm 10\text{V}$, $R_L \geq 2\text{ k}\Omega$	50	160		25	160		25	160		V/mV
Amplifier to Amplifier Coupling	$T_A = 25^\circ\text{C}$, $f = 1\text{ Hz to } 20\text{ kHz}$ (Input Referred) See Crosstalk Test Circuit		-120			-120			-120		dB
Small Signal Bandwidth	LM148 Series $T_A = 25^\circ\text{C}$		1.0			1.0			1.0		MHz
	LM149 Series		4.0			4.0			4.0		MHz
Phase Margin	LM148 Series ($A_V = 1$) $T_A = 25^\circ\text{C}$		60			60			60		degrees
	LM149 Series ($A_V = 5$)		60			60			60		degrees
Slew Rate	LM148 Series ($A_V = 1$) $T_A = 25^\circ\text{C}$		0.5			0.5			0.5		V/μs
	LM149 Series ($A_V = 5$)		2.0			2.0			2.0		V/μs
Output Short Circuit Current	$T_A = 25^\circ\text{C}$		25			25			25		mA
Input Offset Voltage	$R_S \leq 10\text{ k}\Omega$			6.0			7.5			7.5	mV
Input Offset Current				75			125			100	nA

Electrical Characteristics (Continued)

(Note 3)

Parameter	Conditions	LM148/LM149			LM248			LM348			Units
		Min	Typ	Max	Min	Typ	Max	Min	Typ	Max	
Input Bias Current				325			500			400	nA
Large Signal Voltage Gain	$V_S = \pm 15V, V_{OUT} = \pm 10V,$ $R_L > 2 k\Omega$	25			15			15			V/mV
Output Voltage Swing	$V_S = \pm 15V, R_L = 10 k\Omega$ $R_L = 2 k\Omega$	± 12	± 13		± 12	± 13		± 12	± 13		V
		± 10	± 12		± 10	± 12		± 10	± 12		V
Input Voltage Range	$V_S = \pm 15V$	± 12			± 12			± 12			V
Common-Mode Rejection Ratio	$R_S \leq 10 k\Omega$	70	90		70	90		70	90		dB
Supply Voltage Rejection	$R_S \leq 10 k\Omega, \pm 5V \leq V_S \leq \pm 15V$	77	96		77	96		77	96		dB

Note 1: Any of the amplifier outputs can be shorted to ground indefinitely; however, more than one should not be simultaneously shorted as the maximum junction temperature will be exceeded.

Note 2: The maximum power dissipation for these devices must be derated at elevated temperatures and is dictated by $T_{jMAX}, \theta_{jA},$ and the ambient temperature, $T_A.$ The maximum available power dissipation at any temperature is $P_d = (T_{jMAX} - T_A)/\theta_{jA}$ or the $25^\circ C P_{dMAX},$ whichever is less.

Note 3: These specifications apply for $V_S = \pm 15V$ and over the absolute maximum operating temperature range ($T_L \leq T_A \leq T_H$) unless otherwise noted.

Note 4: Refer to RETS 148X for LM148 military specifications and refer to RETS 149X for LM149 military specifications.

Note 5: Human body model, 1.5 kΩ in series with 100 pF.

Cross Talk Test Circuit

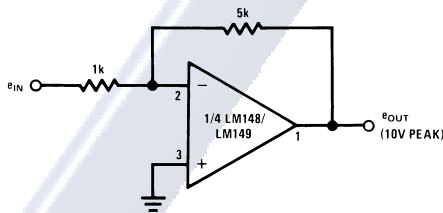

DS007786-6

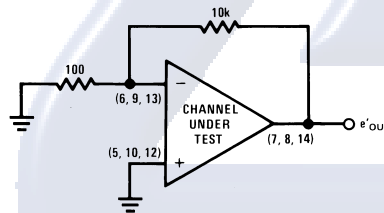

DS007786-7

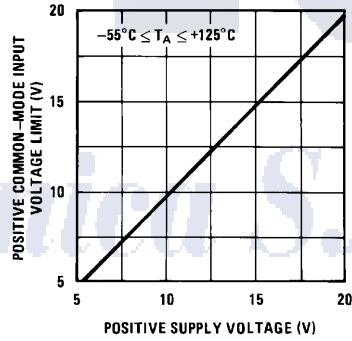

DS007786-43

$V_S = \pm 15V$

Application Hints

The LM148 series are quad low power 741 op amps. In the proliferation of quad op amps, these are the first to offer the convenience of familiar, easy to use operating characteristics of the 741 op amp. In those applications where 741 op amps have been employed, the LM148 series op amps can be employed directly with no change in circuit performance.

The LM149 series has the same characteristics as the LM148 except it has been decompensated to provide a wider bandwidth. As a result the part requires a minimum gain of 5.

Typical Performance Characteristics

Supply Current

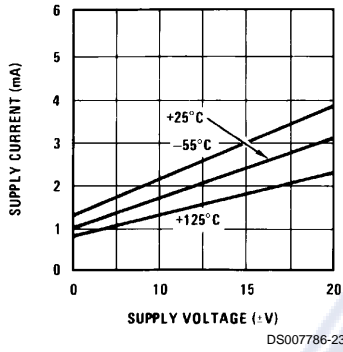

Input Bias Current

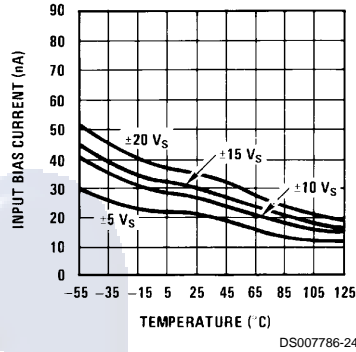

Voltage Swing

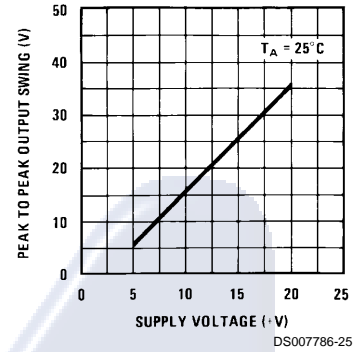

Positive Current Limit

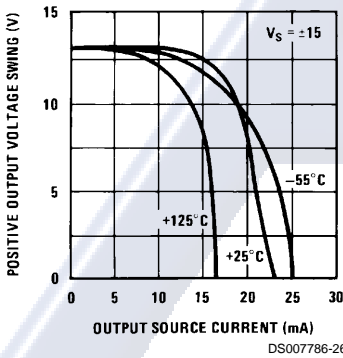

Negative Current Limit

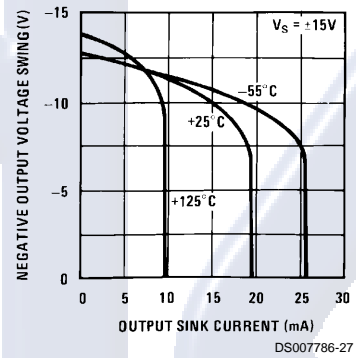

Output Impedance

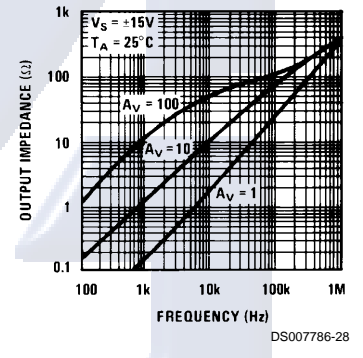

Common-Mode Rejection Ratio

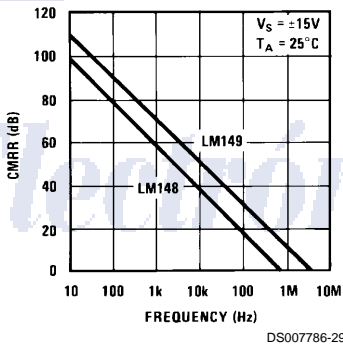

Open Loop Frequency Response

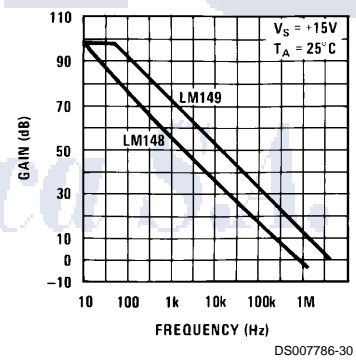

Bode Plot LM148

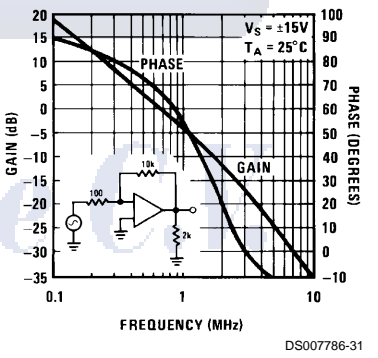

Typical Performance Characteristics (Continued)

Bode Plot LM149

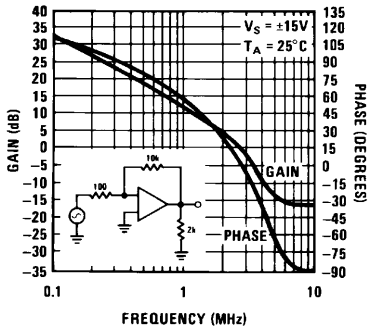

DS007786-32

Large Signal Pulse Response (LM148)

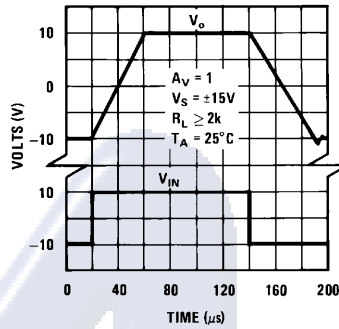

DS007786-33

Large Signal Pulse Response (LM149)

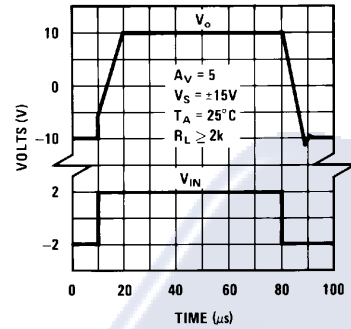

DS007786-34

Small Signal Pulse Response (LM148)

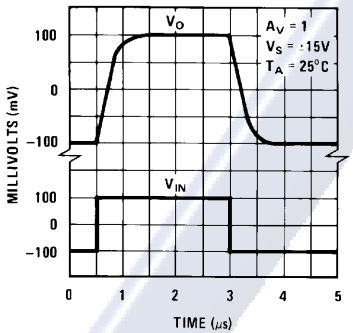

DS007786-35

Small Signal Pulse Response (LM149)

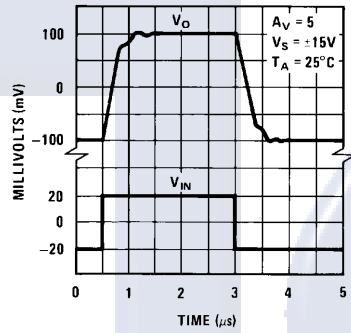

DS007786-36

Undistorted Output Voltage Swing

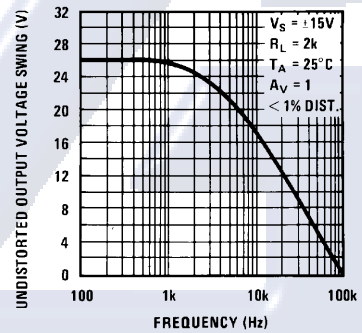

DS007786-37

Gain Bandwidth

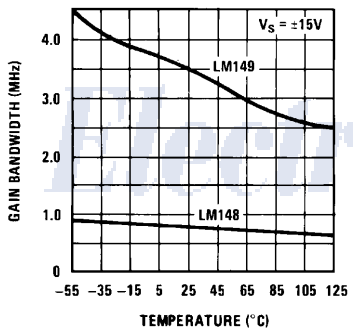

DS007786-38

Slew Rate

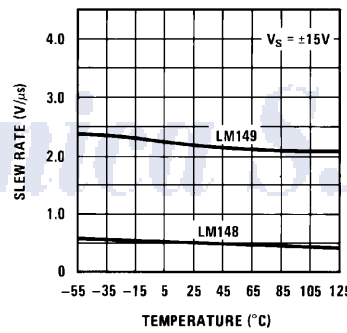

DS007786-39

Inverting Large Signal Pulse Response (LM149)

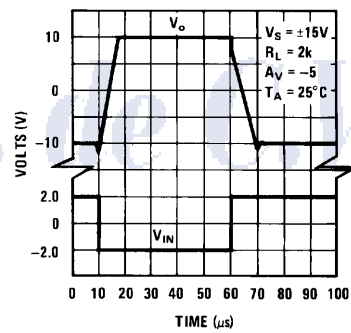

DS007786-40

Typical Performance Characteristics (Continued)

Inverting Large Signal Pulse Response (LM148)

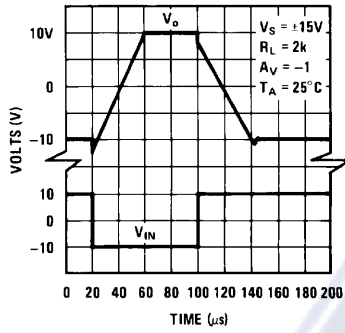

DS007786-41

Input Noise Voltage and Noise Current

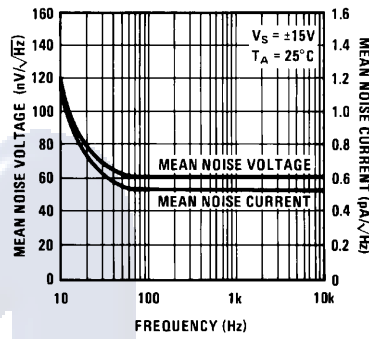

DS007786-42

Positive Common-Mode Input Voltage Limit

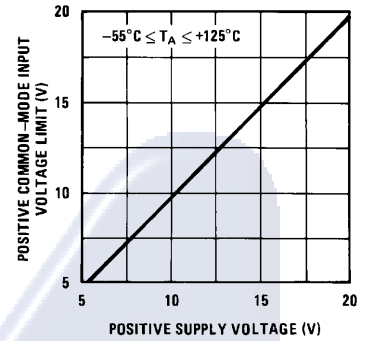

DS007786-43

Negative Common-Mode Input Voltage Limit

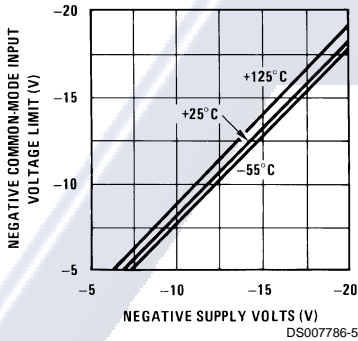

DS007786-5

Application Hints

The LM148 series are quad low power 741 op amps. In the proliferation of quad op amps, these are the first to offer the convenience of familiar, easy to use operating characteristics of the 741 op amp. In those applications where 741 op amps have been employed, the LM148 series op amps can be employed directly with no change in circuit performance.

The LM149 series has the same characteristics as the LM148 except it has been decompensated to provide a wider bandwidth. As a result the part requires a minimum gain of 5.

The package pin-outs are such that the inverting input of each amplifier is adjacent to its output. In addition, the amplifier outputs are located in the corners of the package which simplifies PC board layout and minimizes package related capacitive coupling between amplifiers.

The input characteristics of these amplifiers allow differential input voltages which can exceed the supply voltages. In addition, if either of the input voltages is within the operating common-mode range, the phase of the output remains correct. If the negative limit of the operating common-mode range is exceeded at both inputs, the output voltage will be positive. For input voltages which greatly exceed the maximum supply voltages, either differentially or common-mode, resistors should be placed in series with the inputs to limit the current.

Like the LM741, these amplifiers can easily drive a 100 pF capacitive load throughout the entire dynamic output voltage and current range. However, if very large capacitive loads must be driven by a non-inverting unity gain amplifier, a resistor should be placed between the output (and feedback connection) and the capacitance to reduce the phase shift resulting from the capacitive loading.

The output current of each amplifier in the package is limited. Short circuits from an output to either ground or the power supplies will not destroy the unit. However, if multiple output shorts occur simultaneously, the time duration should be short to prevent the unit from being destroyed as a result of excessive power dissipation in the IC chip.

Application Hints (Continued)

As with most amplifiers, care should be taken lead dress, component placement and supply decoupling in order to ensure stability. For example, resistors from the output to an input should be placed with the body close to the input to minimize "pickup" and maximize the frequency of the feedback pole which capacitance from the input to ground creates.

A feedback pole is created when the feedback around any amplifier is resistive. The parallel resistance and capacitance

from the input of the device (usually the inverting input) to AC ground set the frequency of the pole. In many instances the frequency of this pole is much greater than the expected 3 dB frequency of the closed loop gain and consequently there is negligible effect on stability margin. However, if the feedback pole is less than approximately six times the expected 3 dB frequency a lead capacitor should be placed from the output to the input of the op amp. The value of the added capacitor should be such that the RC time constant of this capacitor and the resistance it parallels is greater than or equal to the original feedback pole time constant.

Typical Applications—LM148

One Decade Low Distortion Sinewave Generator

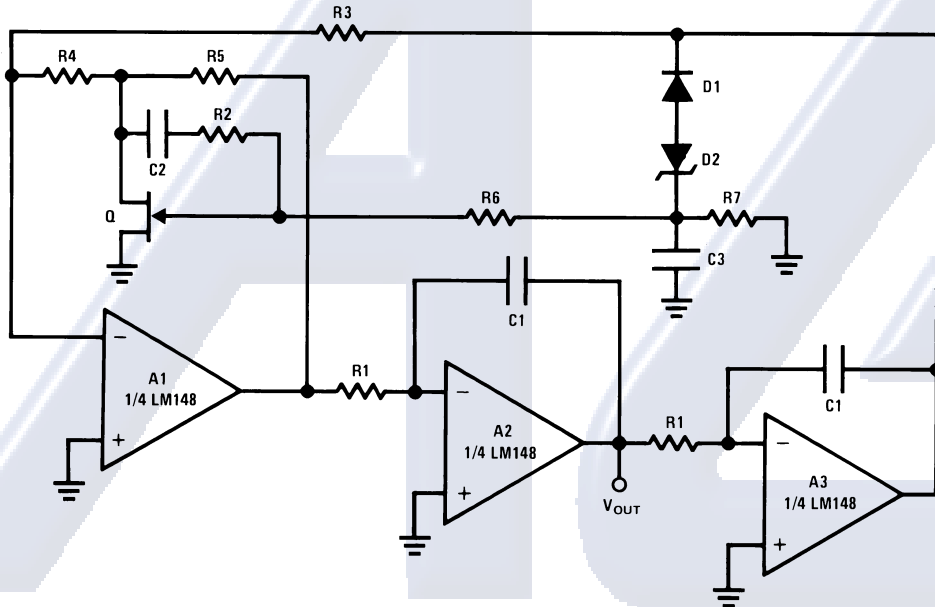

DS007786-8

$$f = \frac{1}{2\pi R1 C1} \times \sqrt{K}, K = \frac{R4 R5}{R3} \left(\frac{1}{r_{DS}} + \frac{1}{R4} + \frac{1}{R5} \right), r_{DS} \approx \frac{R_{ON}}{\left(1 - \frac{V_{GS}}{V_P}\right)^{1/2}}$$

f_{MAX} = 5 kHz, THD ≤ 0.03%
 R1 = 100k pot, C1 = 0.0047 μF, C2 = 0.01 μF, C3 = 0.1 μF, R2 = R6 = R7 = 1M,
 R3 = 5.1k, R4 = 12Ω, R5 = 240Ω, Q = NS5102, D1 = 1N914, D2 = 3.6V avalanche diode (ex. LM103), V_S = ±15V

A simpler version with some distortion degradation at high frequencies can be made by using A1 as a simple inverting amplifier, and by putting back to back zeners in the feedback loop of A3.

Typical Applications—LM148 (Continued)

Low Cost Instrumentation Amplifier

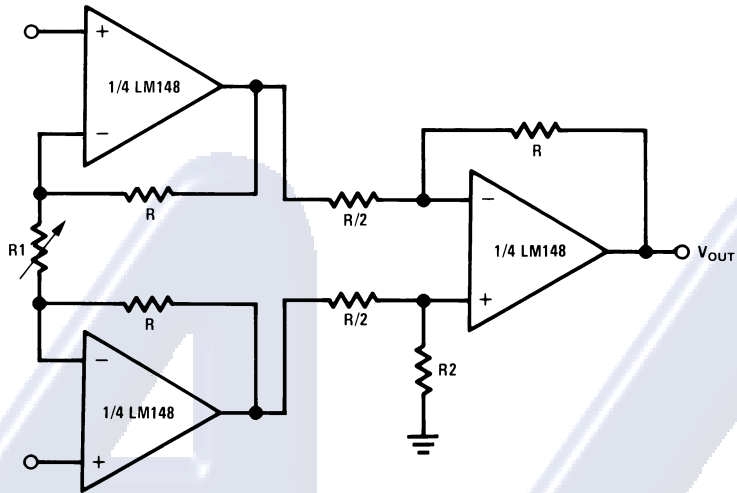

DS007786-9

$$V_{OUT} = 2 \left(\frac{2R}{R1} + 1 \right) \cdot V_S - 3V \leq V_{IN\ CM} \leq V_S^+ - 3V,$$

$V_S = \pm 15V$

$R = R2$, trim $R2$ to boost CMRR

Low Drift Peak Detector with Bias Current Compensation

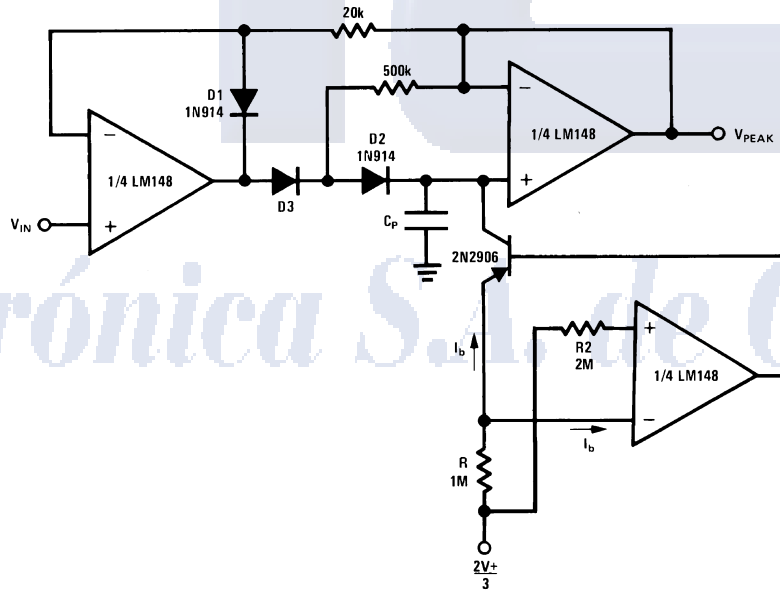

DS007786-10

Adjust R for minimum drift
 D3 low leakage diode
 D1 added to improve speed
 $V_S = \pm 15V$

Typical Applications—LM148 (Continued)

Universal State-Variable Filter

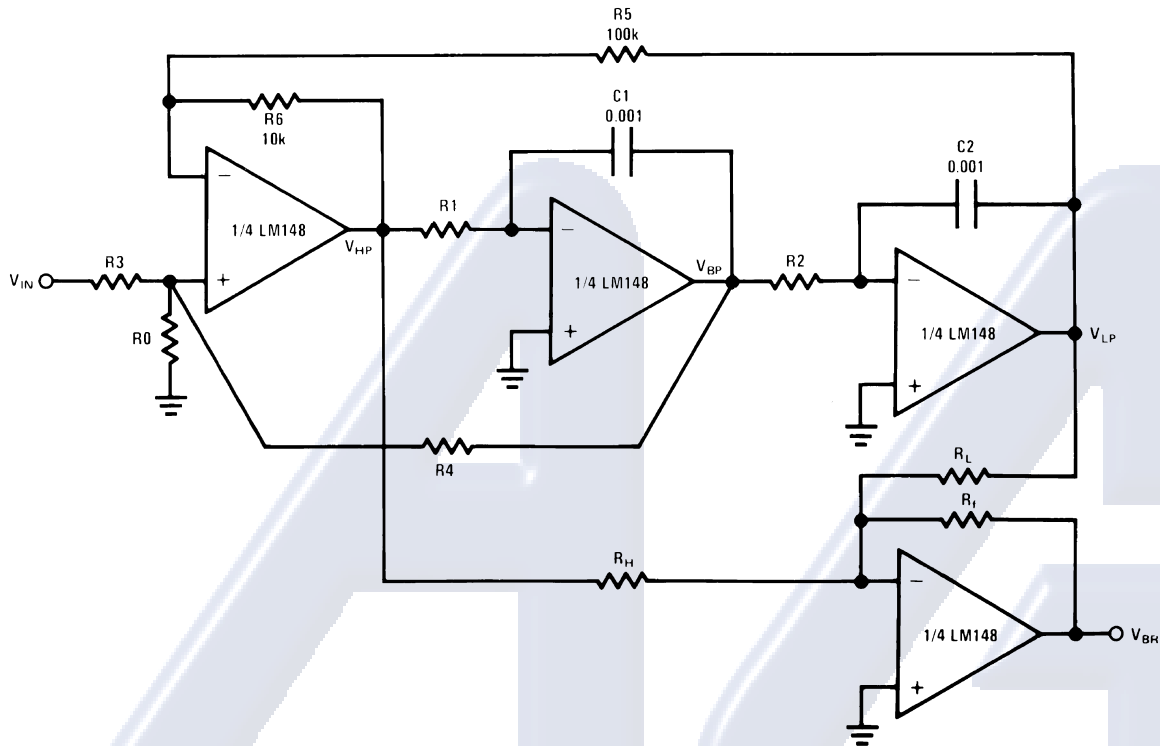

DS007786-11

Tune Q through R0.
 For predictable results: $f_o Q \leq 4 \times 10^4$
 Use Band Pass output to tune for Q

$$\frac{V(s)}{V_{IN}(s)} = \frac{N(s)}{D(s)}, \quad D(s) = s^2 + \frac{s\omega_o}{Q} + \omega_o^2$$

$$N_{HP}(s) = s^2 H_{OHP}, \quad N_{BP}(s) = \frac{-s\omega_o H_{OBP}}{Q}, \quad N_{LP} = \omega_o^2 H_{OLP}$$

$$f_o = \frac{1}{2\pi} \sqrt{\frac{R6}{R5}} \sqrt{\frac{1}{t_1 t_2}}, \quad t_i = R_i C_i, \quad Q = \left(\frac{1 + R4|R3 + R4|R0}{1 + R6|R5} \right) \left(\frac{R6 t_1}{R5 t_2} \right)^{1/2}$$

$$f_{NOTCH} = \frac{1}{2\pi} \left(\frac{R_H}{R_L t_1 t_2} \right)^{1/2}, \quad H_{OHP} = \frac{1 + R6|R5}{1 + R3|R0 + R3|R4}, \quad H_{OBP} = \frac{1 + R4|R3 + R4|R0}{1 + R3|R0 + R3|R4}$$

$$H_{OLP} = \frac{1 + R5|R6}{1 + R3|R0 + R3|R4}$$

Electronica S.A. de C.V.

Typical Applications—LM148 (Continued)

A 1 kHz 4 Pole Butterworth

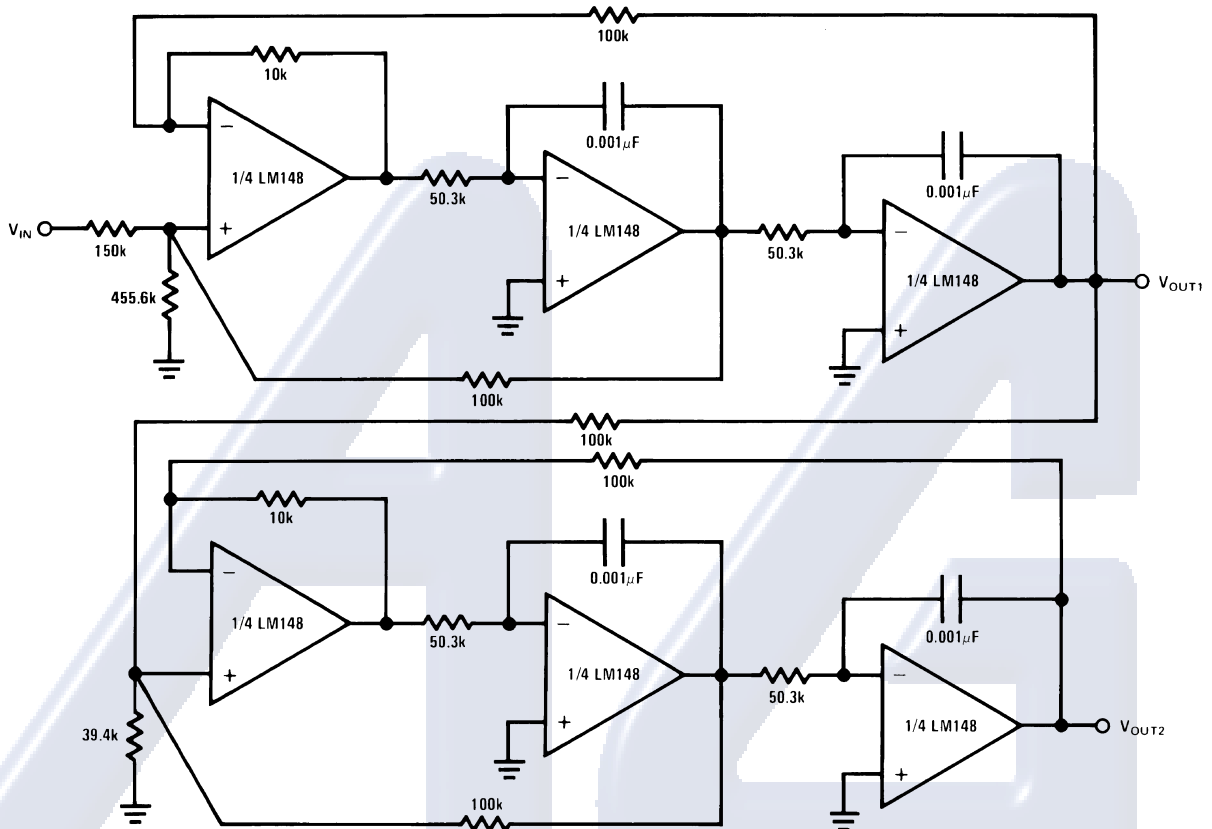

Use general equations, and tune each section separately
 $Q_{1stSECTION} = 0.541$, $Q_{2ndSECTION} = 1.306$
 The response should have 0 dB peaking

DS007786-12

A 3 Amplifier Bi-Quad Notch Filter

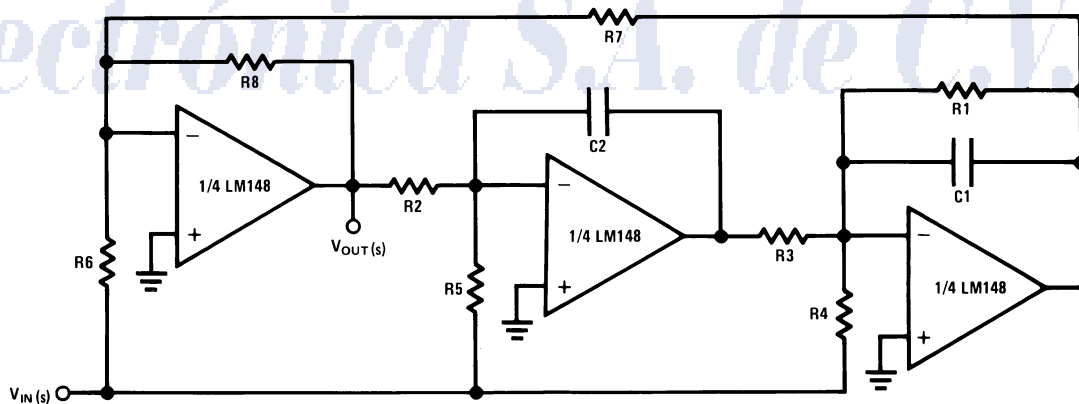

DS007786-13

$$Q = \sqrt{\frac{R8}{R7}} \times \frac{R1C1}{\sqrt{R3C2R2C1}}, \quad f_o = \frac{1}{2\pi} \sqrt{\frac{R8}{R7}} \times \frac{1}{\sqrt{R2R3C1C2}}, \quad f_{NOTCH} = \frac{1}{2\pi} \sqrt{\frac{R6}{R3R5R7C1C2}}$$

Necessary condition for notch: $\frac{1}{R6} = \frac{R1}{R4R7}$

Ex: $f_{NOTCH} = 3 \text{ kHz}$, $Q = 5$, $R1 = 270k$, $R2 = R3 = 20k$, $R4 = 27k$, $R5 = 20k$, $R6 = R8 = 10k$, $R7 = 100k$, $C1 = C2 = 0.001 \mu\text{F}$
 Better noise performance than the state-space approach.

Typical Applications—LM148 (Continued)

A 4th Order 1 kHz Elliptic Filter (4 Poles, 4 Zeros)

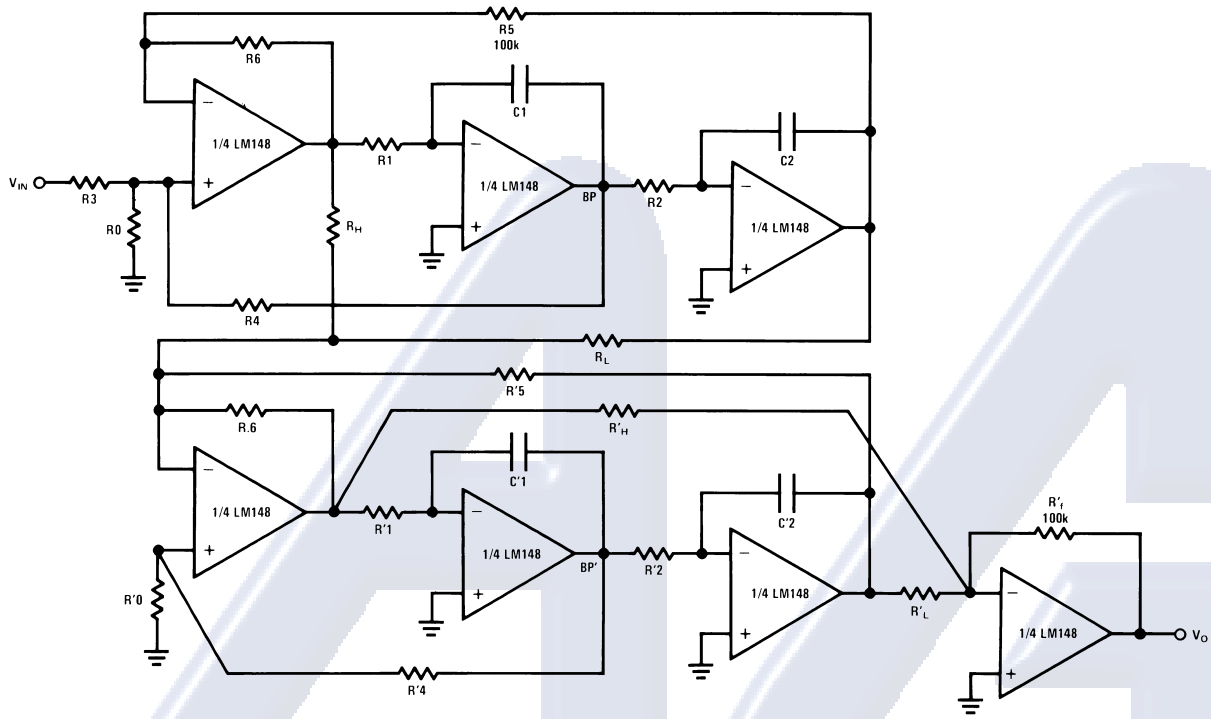

DS007786-14

$R1C1 = R2C2 = t$

$R'1C'1 = R'2C'2 = t'$

$f_c = 1 \text{ kHz}, f_s = 2 \text{ kHz}, f_p = 0.543, f_z = 2.14, Q = 0.841, f'_p = 0.987, f'_z = 4.92, Q' = 4.403$, normalized to ripple BW

$$f = \frac{1}{2\pi R1C1} \times \sqrt{K}, K = \frac{R4R5}{R3} \left(\frac{1}{r_{DS}} + \frac{1}{R4} + \frac{1}{R5} \right), r_{DS} \approx \frac{R_{ON}}{\left(1 - \frac{V_{GS}}{V_P} \right)^{3/2}}$$

Use the BP outputs to tune Q, Q', tune the 2 sections separately

$R1 = R2 = 92.6k, R3 = R4 = R5 = 100k, R6 = 10k, R0 = 107.8k, R_L = 100k, R_H = 155.1k,$

$R'1 = R'2 = 50.9k, R'4 = R'5 = 100k, R'6 = 10k, R'0 = 5.78k, R'_L = 100k, R'_H = 248.12k, R'f = 100k$. All capacitors are 0.001 μF .

Electrónica S.A. de C.V.

Lowpass Response

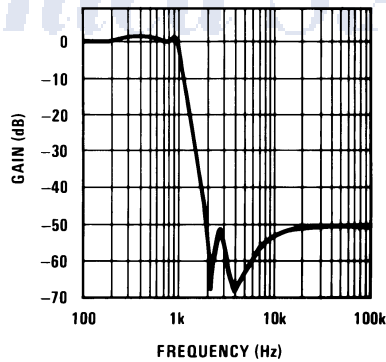

DS007786-15

Typical Applications—LM149

Minimum Gain to Insure LM149 Stability

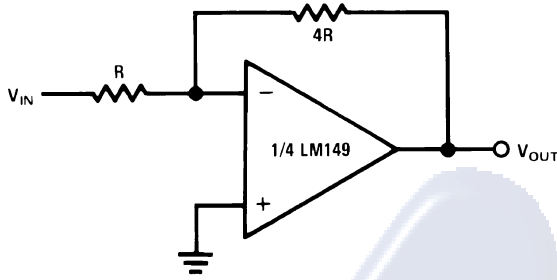

DS007786-16

$$A_{CL(s)} = \frac{V_{OUT}}{V_{IN}} = \frac{-4}{\left(1 + \frac{5}{A_{OL(s)}}\right)} \approx -4$$

$V_O|_{V_{IN}=0} \approx \pm 5 V_{OS}$
 Power BW = 40 kHz
 Small Signal BW = G BW/5

The LM149 as a Unity Gain Inverter

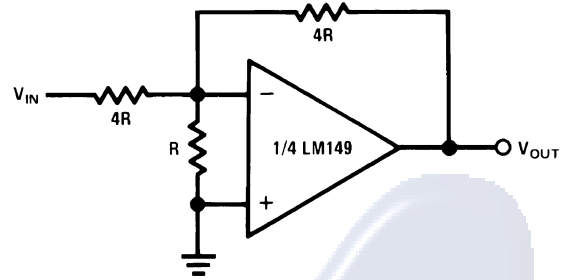

DS007786-17

$$A_{CL(s)} = \frac{V_{OUT}}{V_{IN}} = \left(\frac{-1}{1 + \frac{6}{A_{OL(s)}}}\right) \approx -1$$

$V_O|_{V_{IN}=0} \approx \pm 5 V_{OS}$
 Small Signal BW = G BW/5

Non-inverting-Integrator Bandpass Filter

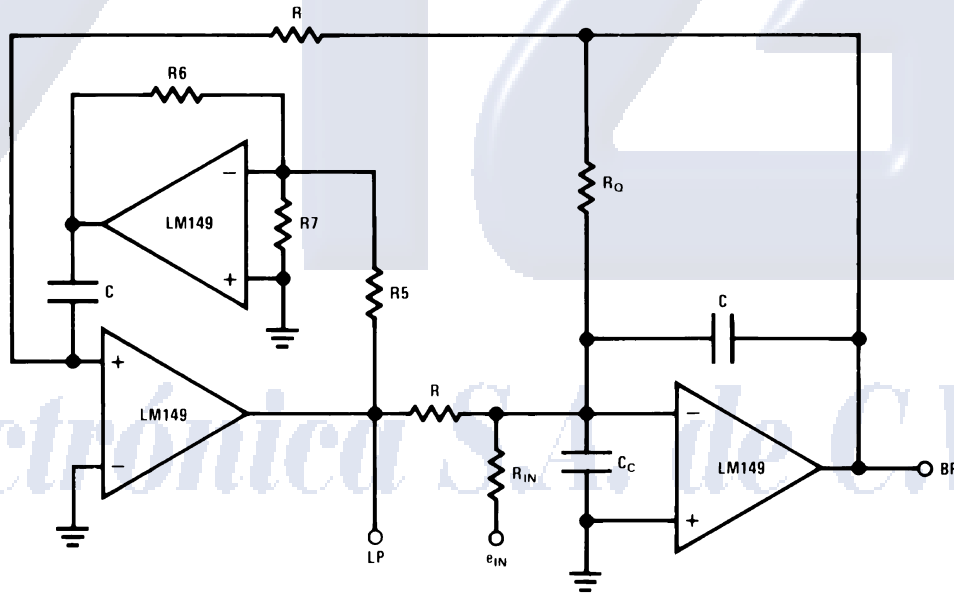

DS007786-18

For stability purposes: $R_7 = R_6/4$, $10R_6 = R_5$, $C_C = 10C$

$$f_O = \frac{1}{2\pi} \sqrt{\frac{R_5}{R_6}} \times \frac{1}{RC}, \quad Q = \frac{R_O}{R} \sqrt{\frac{R_5}{R_6}}, \quad H_{O_{BP}} = \frac{R_O}{R_{IN}}$$

$f_{O(MAX)}, Q_{MAX} = 20 \text{ kHz}, 10$
 Better Q sensitivity with respect to open loop gain variations than the state variable filter.
 R7, Cc added for compensation

Typical Applications—LM149 (Continued)

Active Tone Control with Full Output Swing (No Slew Limiting at 20 kHz)

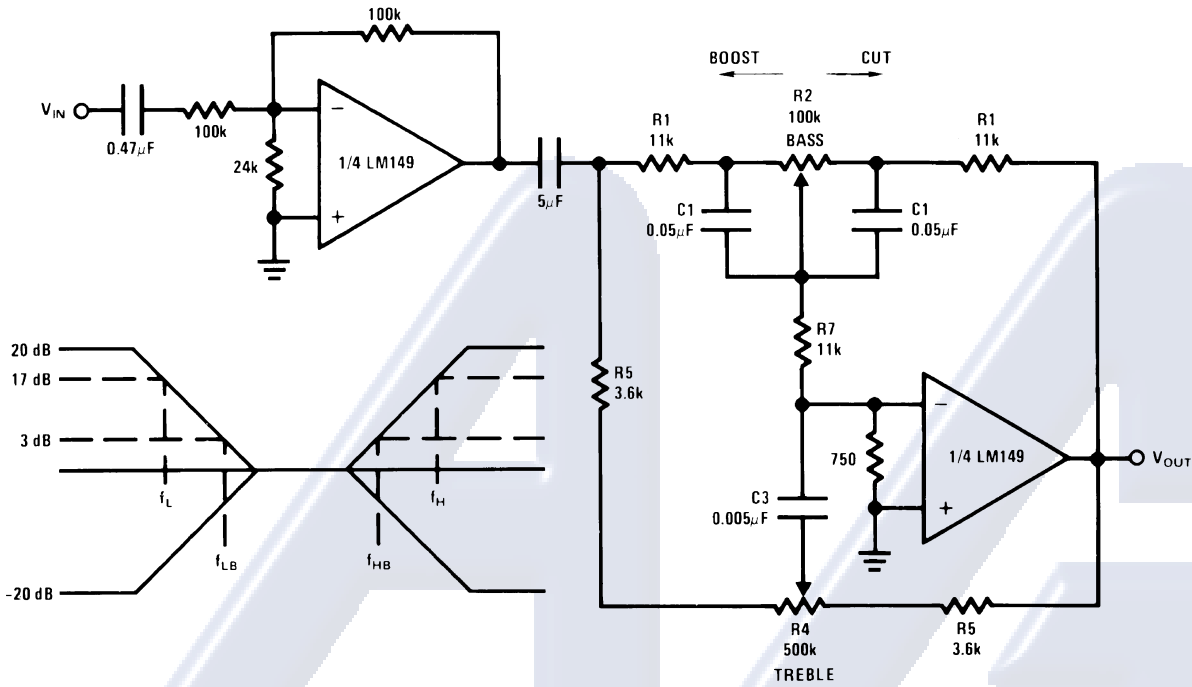

$V_S = \pm 15V$, $V_{OUT(MAX)} = 9.1 V_{RMS}$,
 $f_{MAX} = 20\text{ kHz}$, $THD \leq 1\%$
 Duplicate the above circuit for stereo

$$f_L = \frac{1}{2\pi R2 C1}, f_{LB} = \frac{1}{2\pi R1 C1}$$

$$f_H = \frac{1}{2\pi R5 C3}, f_{HB} = \frac{1}{2\pi (R1 + 2R7) C3}$$

Max Bass Gain $\approx (R1 + R2)/R1$
 Max Treble Gain $\approx (R1 + 2R7)/R5$
 as shown: $f_L \approx 32\text{ Hz}$, $f_{LB} \approx 320\text{ Hz}$
 $f_H = 11\text{ kHz}$, $f_{HB} = 1.1\text{ Hz}$

DS007786-19

Electrónica S.A. de C.V.

Typical Applications—LM149 (Continued)

Triangular Squarewave Generator

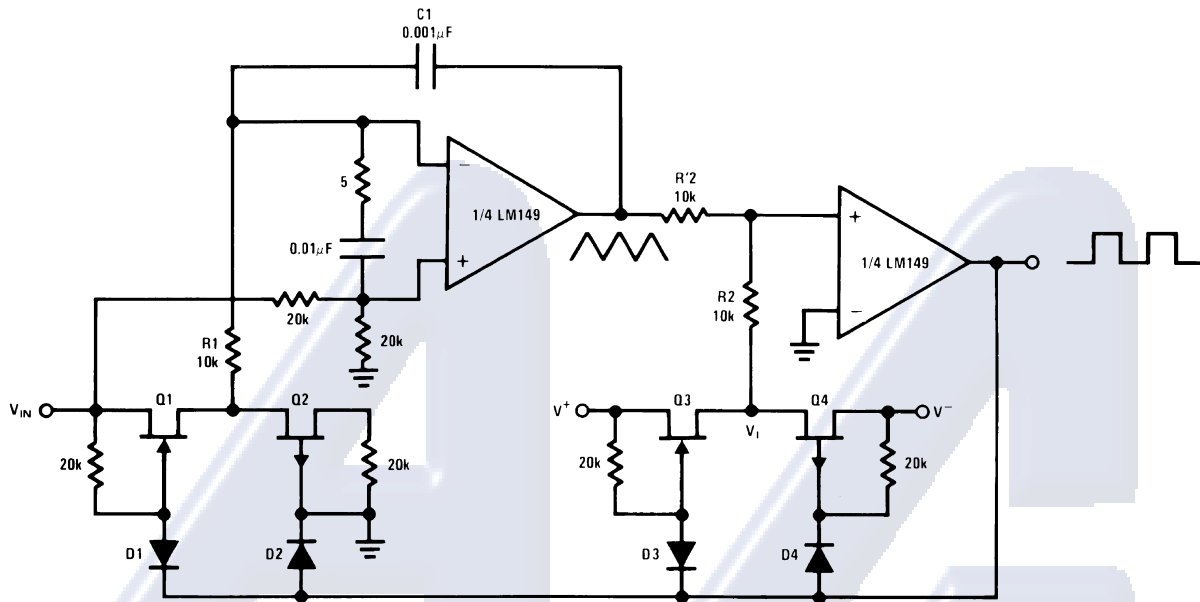

DS007786-20

$$f = \frac{K \times V_{IN}}{8V^+ C_1 R_1}, \quad K = R_2/R'_2, \quad \frac{2V_1}{K} < 25V, \quad V^+ = V^-, \quad V_S = \pm 15V$$

Use LM125 for $\pm 15V$ supply

The circuit can be used as a low frequency V/F for process control.

Q1, Q3: KE4393, Q2, Q4: P1087E, D1–D4 = 1N914

Electrónica S.A. de C.V.

Typical Simulation

LM148, LM149, LM741 Macromodel for Computer Simulation

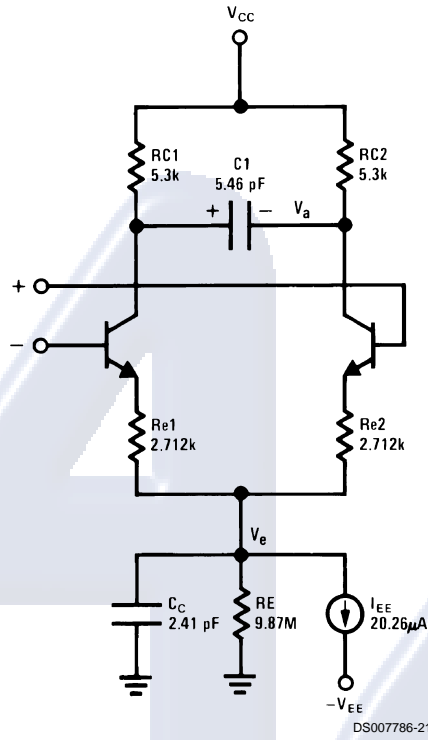

For more details, see IEEE Journal of Solid-State Circuits, Vol. SC-9, No. 6, December 1974

Note 6: $\omega_1 = 112|S = 8 \times 10^{-16}$

Note 7: $\omega_2 = 144 * C2 = 6 \text{ pF}$ for LM149

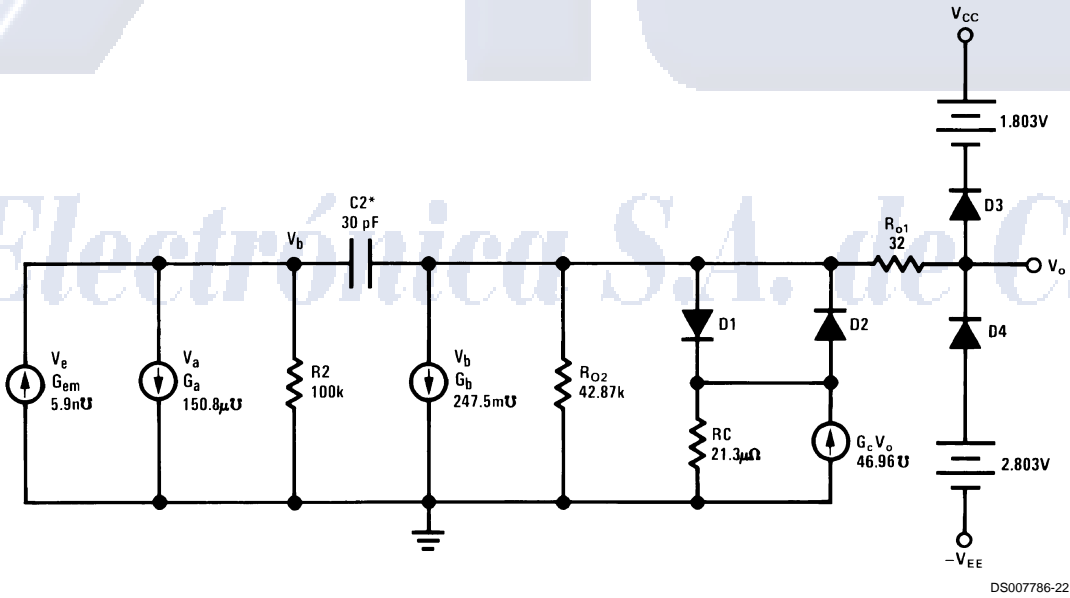

LM148/LM149/LM248/LM348

Connection Diagram

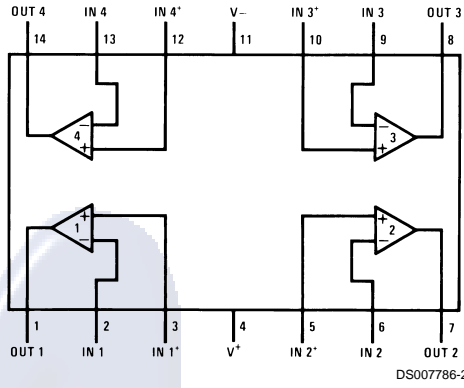

DS007786-2

Top View

Order Number LM148J, LM148J/883, LM149J/883, LM248J, LM348M, or LM348N
 See NS Package Number J14A, M14A or N14A
 LM148J is available per JM38510/11001

Electrónica S.A. de C.V.

Physical Dimensions inches (millimeters) unless otherwise noted

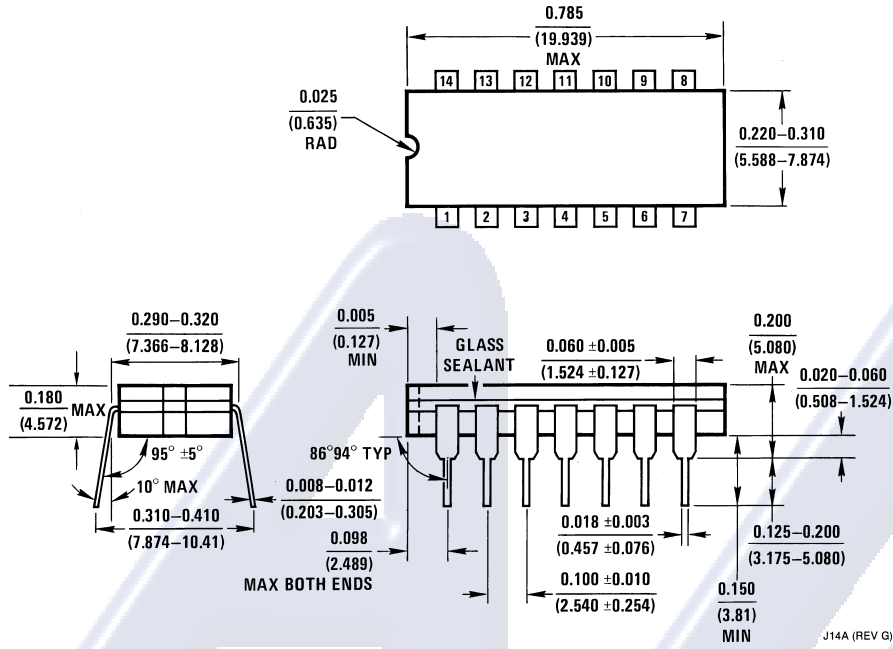

Ceramic Dual-In-Line Package (J)
Order Number LM148J, LM148J/883, LM149J/883, LM248J
NS Package Number J14A

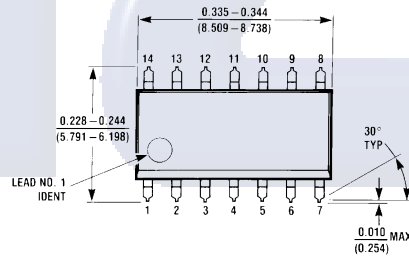

S.O. Package (M)
Order Number LM348M or LM348MX
NS Package Number M14A

Electrónica S.A. de C.V.

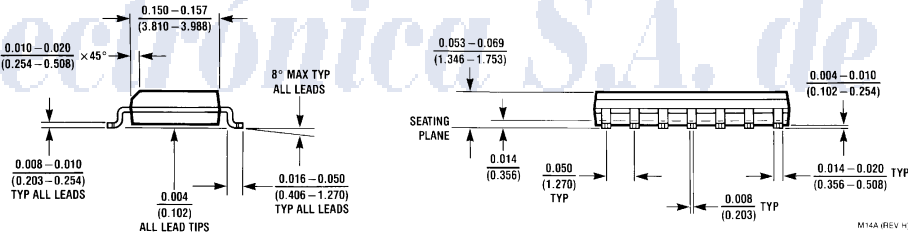

Physical Dimensions inches (millimeters) unless otherwise noted (Continued)

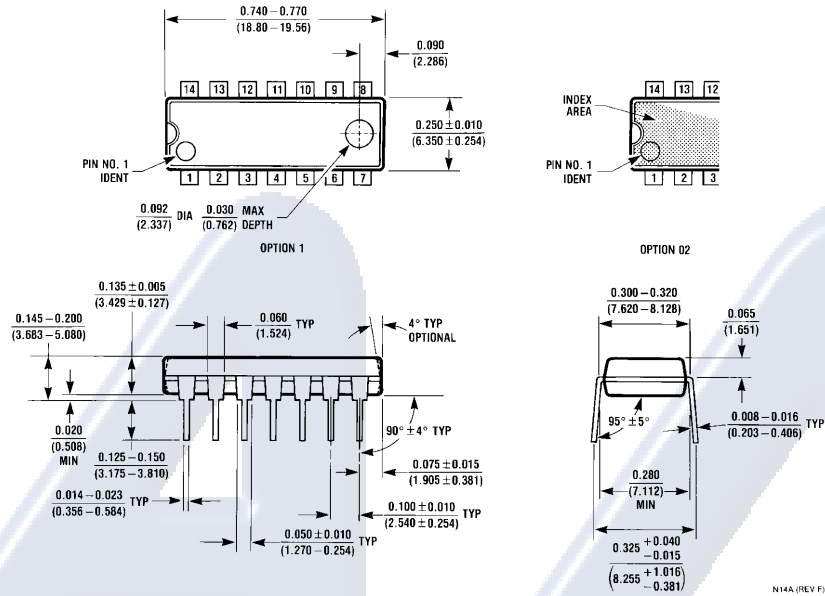

Molded Dual-In-Line Package (N)
Order Number LM348N
NS Package Number N14A

Electrónica S.A. de C.V.

LIFE SUPPORT POLICY

NATIONAL'S PRODUCTS ARE NOT AUTHORIZED FOR USE AS CRITICAL COMPONENTS IN LIFE SUPPORT DEVICES OR SYSTEMS WITHOUT THE EXPRESS WRITTEN APPROVAL OF THE PRESIDENT AND GENERAL COUNSEL OF NATIONAL SEMICONDUCTOR CORPORATION. As used herein:

1. Life support devices or systems are devices or systems which, (a) are intended for surgical implant into the body, or (b) support or sustain life, and whose failure to perform when properly used in accordance with instructions for use provided in the labeling, can be reasonably expected to result in a significant injury to the user.
2. A critical component is any component of a life support device or system whose failure to perform can be reasonably expected to cause the failure of the life support device or system, or to affect its safety or effectiveness.



National Semiconductor Corporation
 Americas
 Tel: 1-800-272-9959
 Fax: 1-800-737-7018
 Email: support@nsc.com
 www.national.com

National Semiconductor Europe
 Fax: +49 (0) 180-530 85 86
 Email: europe.support@nsc.com
 Deutsch Tel: +49 (0) 69 9508 6208
 English Tel: +44 (0) 870 24 0 2171
 Français Tel: +33 (0) 1 41 91 8790

National Semiconductor Asia Pacific Customer Response Group
 Tel: 65-2544466
 Fax: 65-2504466
 Email: ap.support@nsc.com

National Semiconductor Japan Ltd.
 Tel: 81-3-5639-7560
 Fax: 81-3-5639-7507