



LM193, A LM293, A - LM393, A

Low Power Dual Voltage Comparators

- Wide single supply voltage range or dual supplies : +2V to +36V or $\pm 1V$ to $\pm 18V$
- Very low supply current (0.4mA) independent of supply voltage (1mW/comparator at +5V)
- Low input bias current: 25nA typ.
- Low input offset current: $\pm 5nA$ typ.
- Low input offset voltage: $\pm 1mV$ typ.
- Input common-mode voltage range includes ground
- Low output saturation voltage: 250mV typ. ($I_o = 4mA$)
- Differential input voltage range equal to the supply voltage
- TTL, DTL, ECL, MOS, CMOS compatible outputs

Description

These devices consist of two independent low voltage comparators designed specifically to operate from a single supply over a wide range of voltages. Operation from split power supplies is also possible.

These comparators also have a unique characteristic in that the input common-mode voltage range includes ground even though operated from a single power supply voltage.

Order Codes

Part Number	Temperature Range	Package	Packaging
LM193AD/LM193ADT	-55°C, +125°C	SO	Tube or Tape & Reel
LM193AN		DIP	Tube
LM193D/LM193DT		SO	Tube or Tape & Reel
LM193N		DIP	Tube
LM293AD/LM293ADT	-40°C, +105°C	SO	Tube or Tape & Reel
LM293AN		DIP	Tube
LM293D/LM293DT		SO	Tube or Tape & Reel
LM293N		DIP	Tube
LM293PT		TSSOP (Thin Shrink Outline Package)	Tape & Reel
LM293ST		Mini SO	Tape & Reel
LM393AD/LM393ADT	0°C, +70°C	SO	Tube or Tape & Reel
LM393D/LM393DT		SO	Tube or Tape & Reel
LM393N		DIP	Tube
LM393PT		TSSOP (Thin Shrink Outline Package)	Tape & Reel
LM393ST		Mini SO	Tape & Reel
LM393YDT/YD	-40°C, +125°C	SO (automotive grade level)	Tube or Tape & Reel

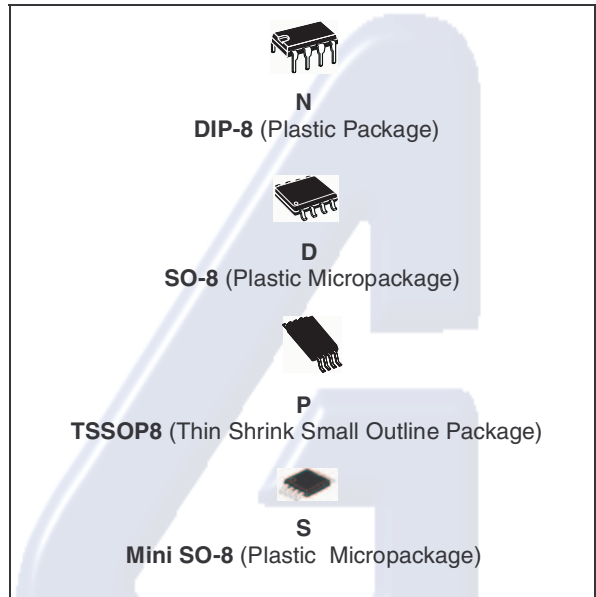

Pin Connections (top view)

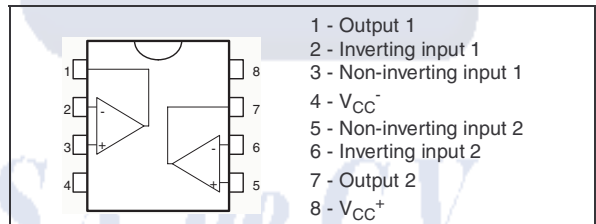

1 Schematic Diagram (1/2 LM193)

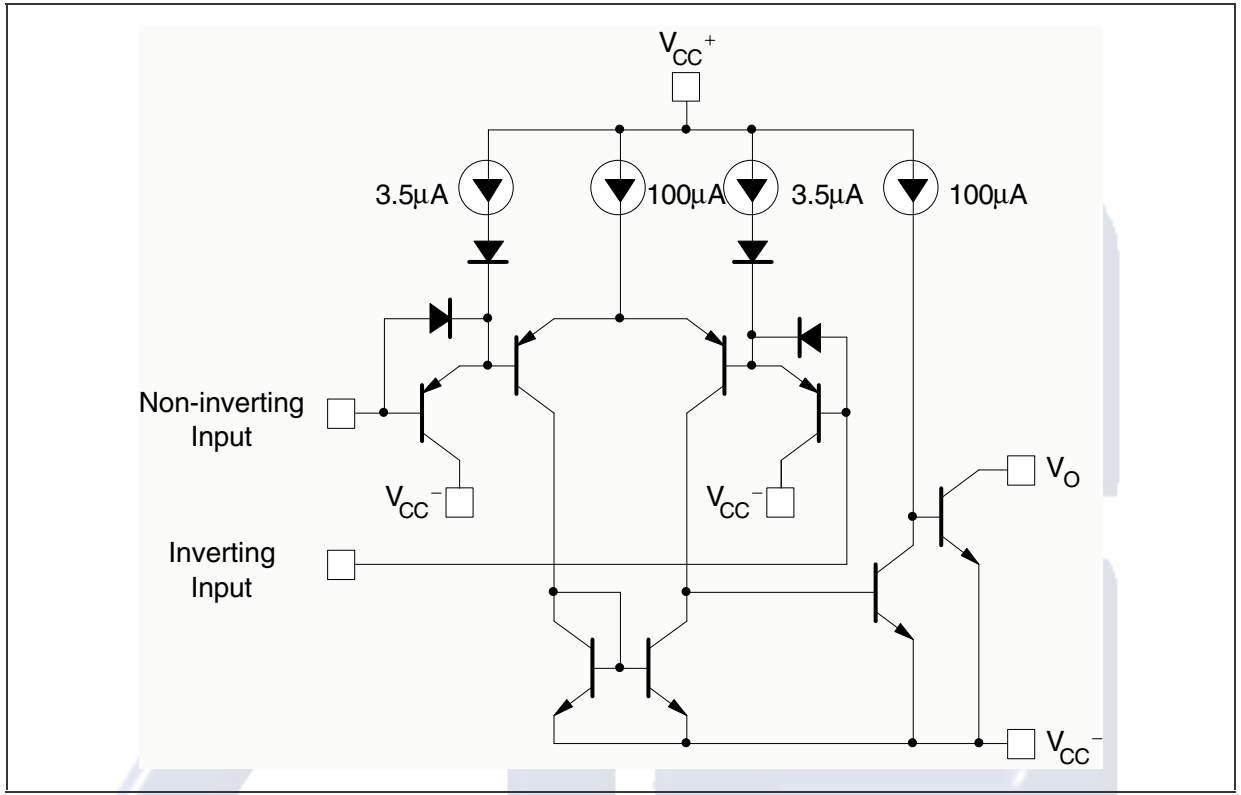

Electrónica S.A. de C.V.

Absolute Maximum Ratings

LM193, A - LM293, A - LM393, A

2 Absolute Maximum Ratings

Table 1. Key parameters and their absolute maximum ratings

Symbol	Parameter	Value	Unit	
V _{cc}	Supply voltage	±18 or 36	V	
V _{id}	Differential Input Voltage	±36	V	
V _i	Input Voltage	-0.3 to +36	V	
	Output Short-circuit to Ground - note ¹	Infinite		
P _d	Power Dissipation ²	DIP-8 SO-8 TSSOP8 Mini SO-8	1250 710 625 580	mW
T _{stg}	Storage Temperature Range	-65 to +150	°C	

1) Short-circuits from the output to V_{CC}⁺ can cause excessive heating and eventual destruction. The maximum output current is approximately 20mA independent of the magnitude of V_{CC}⁺.

2) P_d is calculated with T_{amb} = +25°C, T_j = +150°C and R_{thja} = 100°C/W for DIP8 package
 = 175°C/W for SO8 package
 = 200°C/W for TSSOP8 package
 = 215°C/W for Mini SO8 package

Table 2. Operating Conditions

Symbol	Parameter	Value	Unit	
V _{icm}	Common Mode Input Voltage Range	0 to V _{CC} ⁺ -1.5	V	
T _{oper}	Operating Free-Air Temperature range	LM193, A LM293, A LM393, A	-55 to +125 -40 to +125 0 to +70	°C

Electrónica S.A. de C.V.

3 Electrical Characteristics

Table 3. $V_{CC}^+ = +5V$, $V_{CC}^- = 0V$, $T_{amb} = +25^\circ C$ (unless otherwise specified)

Symbol	Parameter	LM193A - LM293A LM393A			LM193- LM293 LM393			Unit
		Min.	Typ.	Max.	Min	Typ.	Max.	
V_{io}	Input Offset Voltage - note ¹ $T_{amb} = +25^\circ C$ $T_{min} \leq T_{amb} \leq T_{max}$		1	2 4		1 5 9		mV
I_{io}	Input Offset Current $T_{amb} = +25^\circ C$ $T_{min} \leq T_{amb} \leq T_{max}$		3	25 100		5 50 150		nA
I_{ib}	Input Bias Current (I^+ or I^-) - note ² $T_{amb} = +25^\circ C$ $T_{min} \leq T_{amb} \leq T_{max}$		25	100 300		25 250 400		nA
A_{vd}	Large Signal Voltage Gain $V_{CC} = 15V$, $R_L = 15k\Omega$, $V_o = 1V$ to $11V$	50	200		50	200		V/mV
I_{CC}	Supply Current (all comparators) $V_{CC} = +5V$, no load $V_{CC} = +30V$, no load		0.4 1	1 2.5		0.4 1 2.5		mA
V_{icm}	Input Common Mode Voltage Range - note ³ $V_{CC} = 30V$ $T_{amb} = +25^\circ C$ $T_{min} \leq T_{amb} \leq T_{max}$	0 0		$V_{CC}^+ - 1.5$ $V_{CC}^+ - 2$	0 0		$V_{CC}^+ - 1.5$ $V_{CC}^+ - 2$	V
V_{id}	Differential Input Voltage -note ⁴			V_{CC}^+			V_{CC}^+	
V_{OL}	Low Level Output Voltage $V_{id} = -1V$, $I_{sink} = 4mA$ $T_{amb} = +25^\circ C$ $T_{min} \leq T_{amb} \leq T_{max}$		250	400 700		250 400 700		V
I_{OH}	High Level Output Current ($V_{id} = 1V$) $V_{CC} = V_o = 30V$ $T_{amb} = +25^\circ C$ $T_{min} \leq T_{amb} \leq T_{max}$		0.1	1		0.1 1		nA μA
I_{SINK}	Output Sink Current $V_{id} = 1V$, $V_o = 1.5V$	6	16		6	16		mA
tre	Response Time - note ⁵ $R_L = 5.1k\Omega$ connected to V_{CC}^+		1.3			1.3		μs
trel	Large Signal Response Time $R_L = 5.1k\Omega$ connected to V_{CC}^+ , $e_1 = TTL$, $V_{(ref)} = +1.4v$		300			300		ns

1) At output switch point, $V_o \approx 1.4V$, $R_s = 0$ with V_{CC}^+ from 5V to 30V, and over the full common-mode range (0V to $V_{CC}^+ - 1.5V$).

2) The direction of the input current is out of the IC due to the PNP input stage. This current is essentially constant, independent of the state of the output, so no loading charge exists on the reference of input lines.

3) The input common-mode voltage of either input signal voltage should not be allowed to go negative by more than 0.3V. The upper end of the common-mode voltage range is $V_{CC}^+ - 1.5V$, but either or both inputs can go to +30V without damage.

4) The response time specified is for a 100mV input step with 5mV overdrive. For larger overdrive signals 300ns can be obtained.

5) Positive excursions of input voltage may exceed the power supply level. As long as the other voltage remains within the common-mode range, the comparator will provide a proper output state. The low input voltage state must not be less than -0.3V (or 0.3V below the negative power supply, if used).

Figure 1. Supply current vs. supply voltage

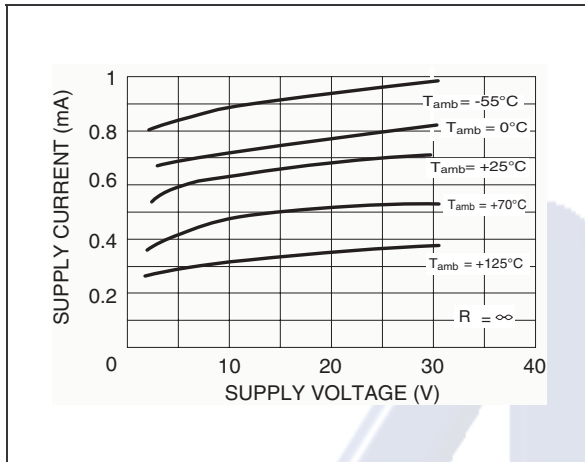

Figure 2. Output saturation voltage vs. output current

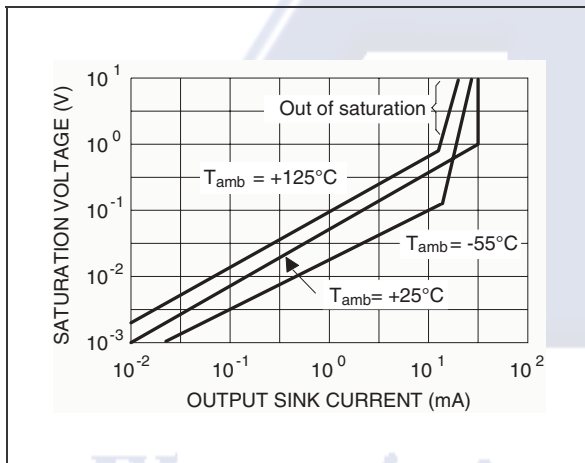

Figure 3. Response time for various input overdrives - positive transition

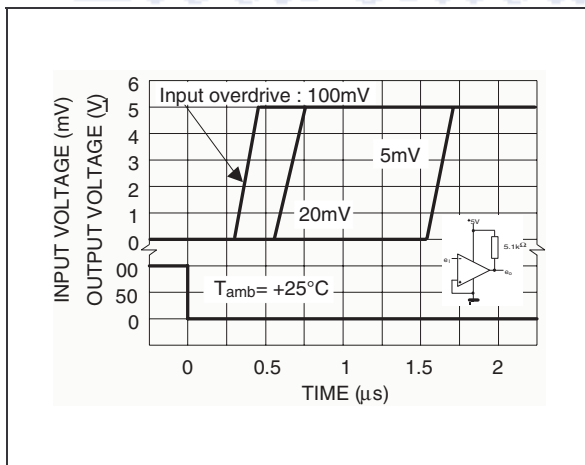

Figure 4. Input current vs. supply voltage

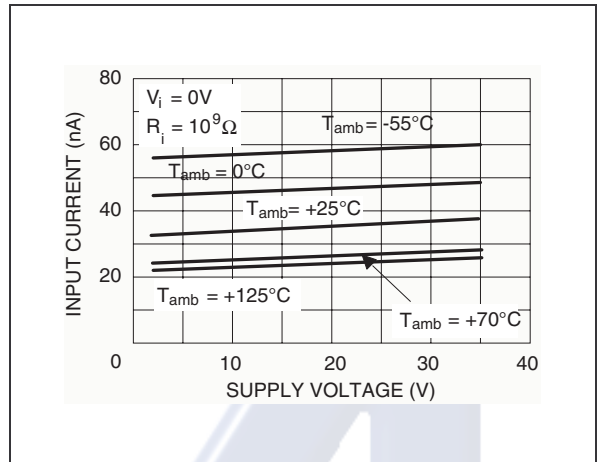
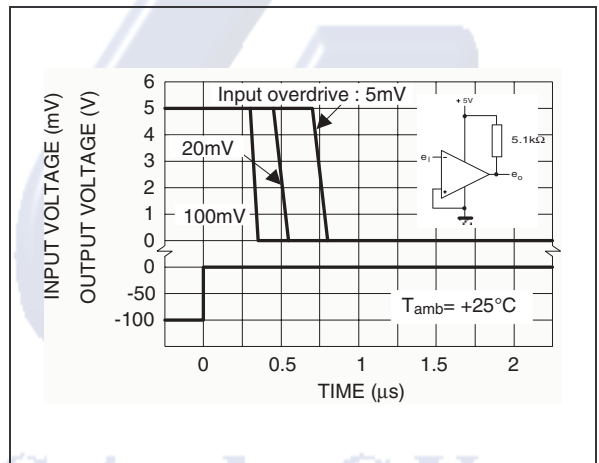

Figure 5. Response time for various input overdrives - negative transition



4 Typical Applications

Figure 6. Basic comparator

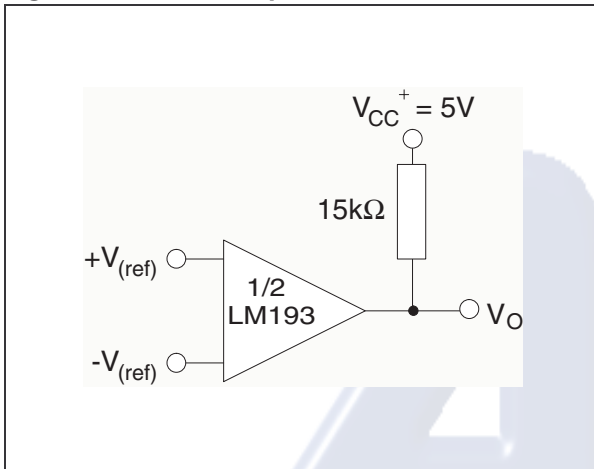

Figure 7. driving TTL

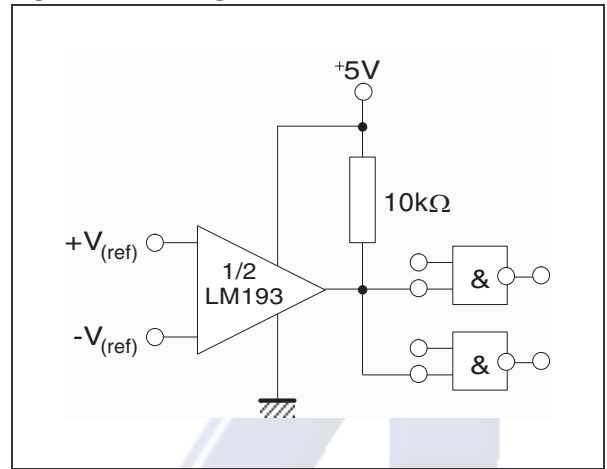

Figure 8. Low frequency op-amp

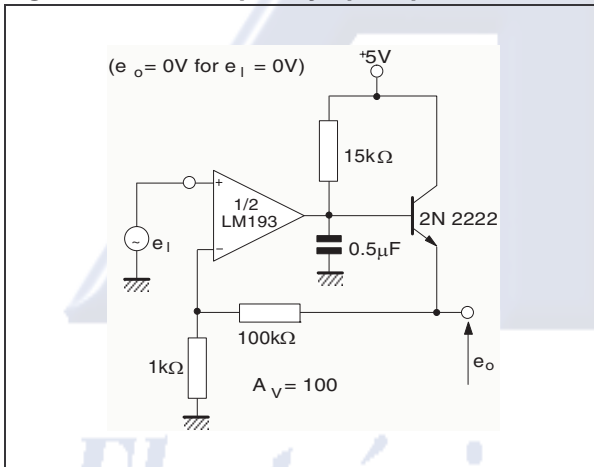

Figure 9. Driving CMOS

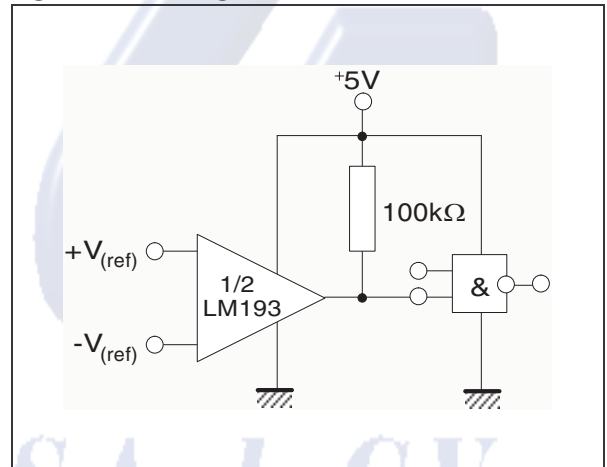

Figure 10. Low frequency op-amp

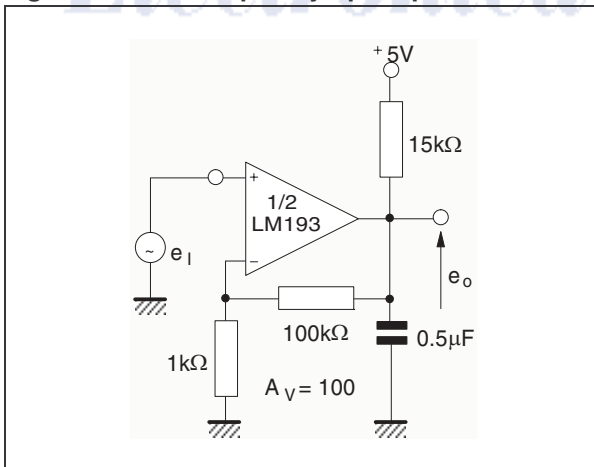
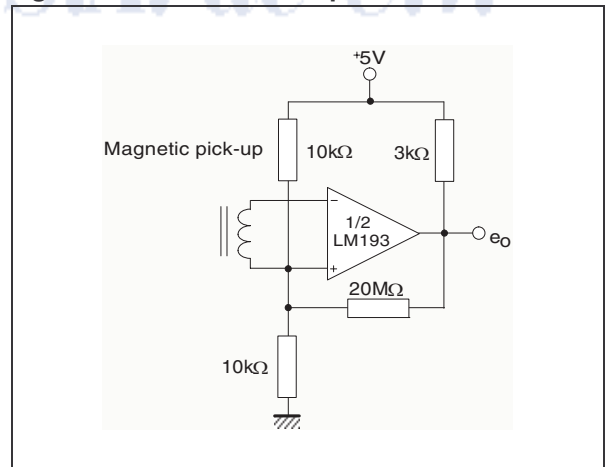

Figure 11. Transducer amplifier



Typical Applications

LM193, A - LM293, A - LM393, A

Figure 12. Low frequency op-amp with offset adjust

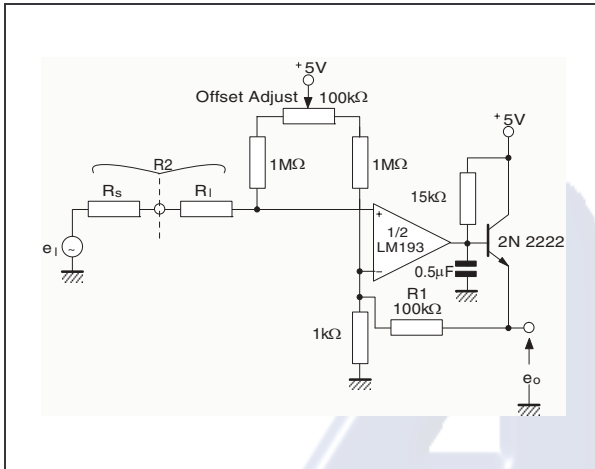

Figure 13. Zero crossing detector (single power supply)

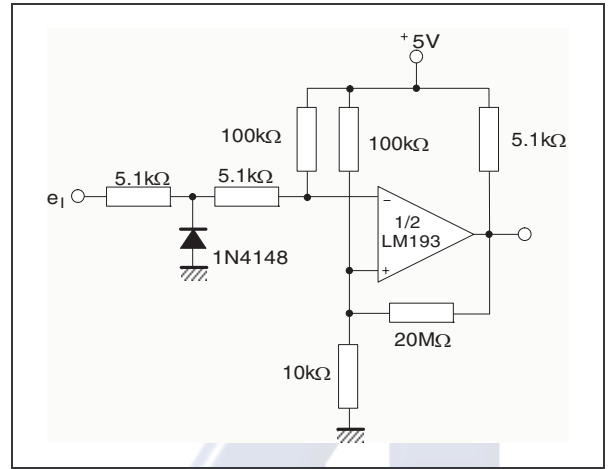

Figure 14. Two-decade high-frequency VCO

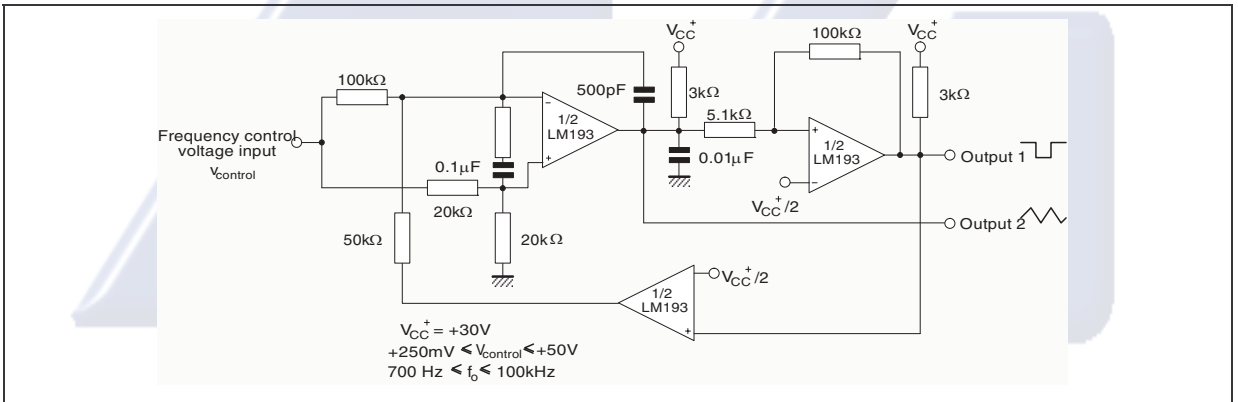

Figure 15. Limit comparator

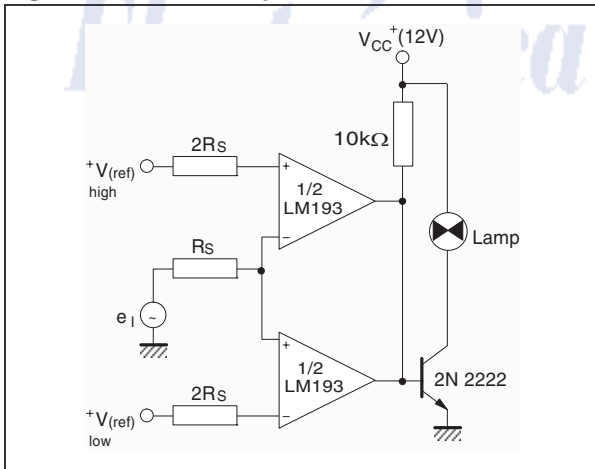

Figure 16. Crystal controlled oscillator

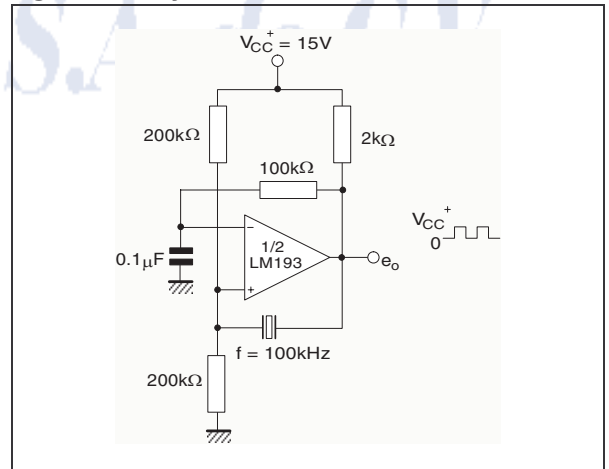

Figure 17. Split-supply applications - zero crossing detector

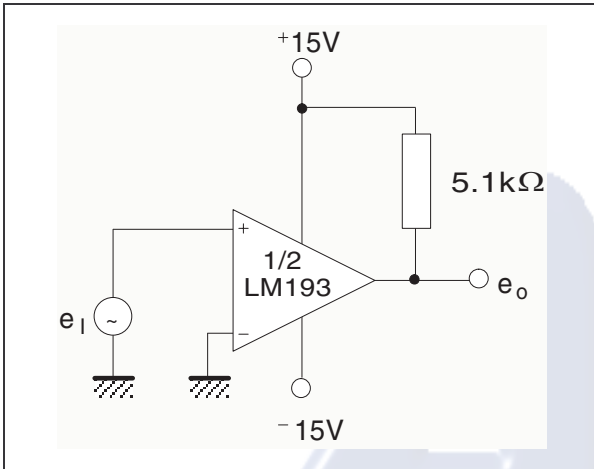
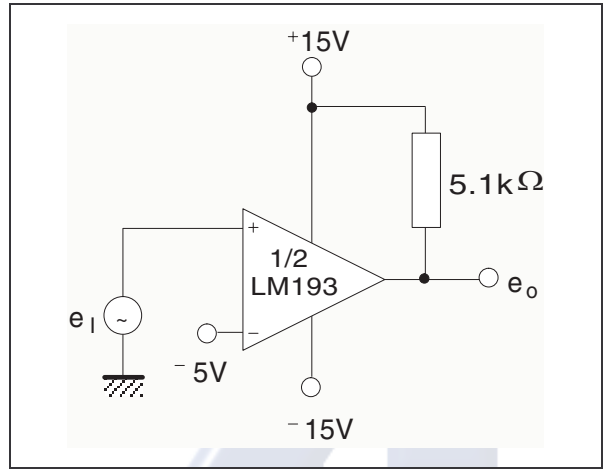

Figure 18. Comparator with a negative reference



Electrónica S.A. de C.V.

5 Package Mechanical Data

5.1 DIP8 package

Plastic DIP-8 MECHANICAL DATA

DIM.	mm.			inch		
	MIN.	TYP	MAX.	MIN.	TYP.	MAX.
A		3.3			0.130	
a1	0.7			0.028		
B	1.39		1.65	0.055		0.065
B1	0.91		1.04	0.036		0.041
b		0.5			0.020	
b1	0.38		0.5	0.015		0.020
D			9.8			0.386
E		8.8			0.346	
e		2.54			0.100	
e3		7.62			0.300	
e4		7.62			0.300	
F			7.1			0.280
l			4.8			0.189
L		3.3			0.130	
Z	0.44		1.6	0.017		0.063

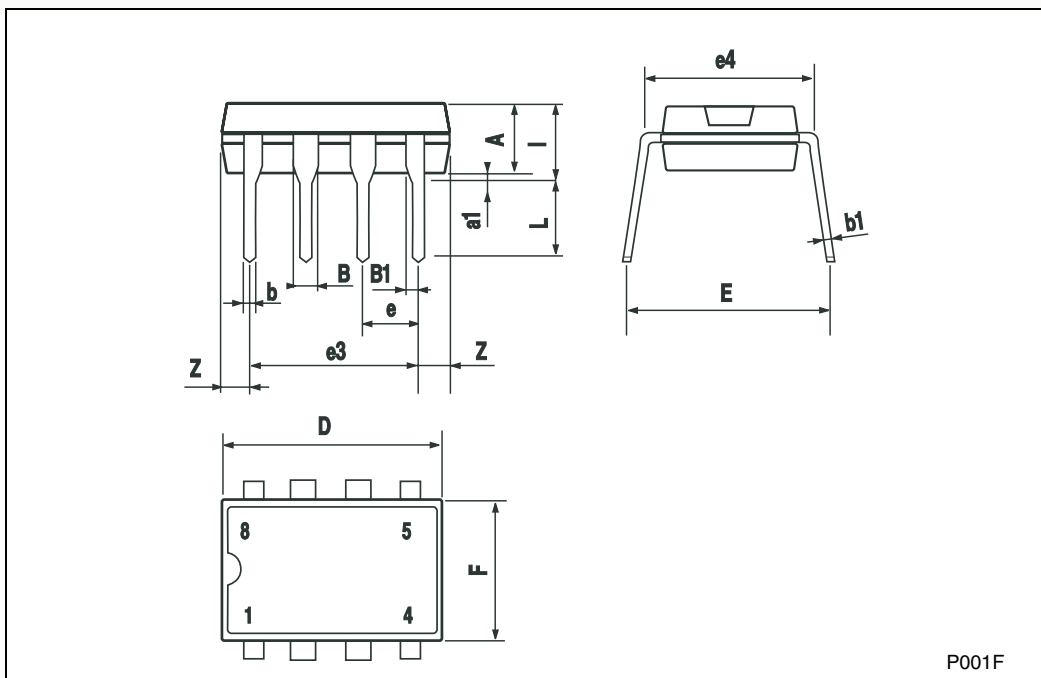

5.2 SO8 package

SO-8 MECHANICAL DATA

DIM.	mm.			inch		
	MIN.	TYP	MAX.	MIN.	TYP.	MAX.
A	1.35		1.75	0.053		0.069
A1	0.10		0.25	0.04		0.010
A2	1.10		1.65	0.043		0.065
B	0.33		0.51	0.013		0.020
C	0.19		0.25	0.007		0.010
D	4.80		5.00	0.189		0.197
E	3.80		4.00	0.150		0.157
e		1.27			0.050	
H	5.80		6.20	0.228		0.244
h	0.25		0.50	0.010		0.020
L	0.40		1.27	0.016		0.050
k	8° (max.)					
ddd			0.1			0.04

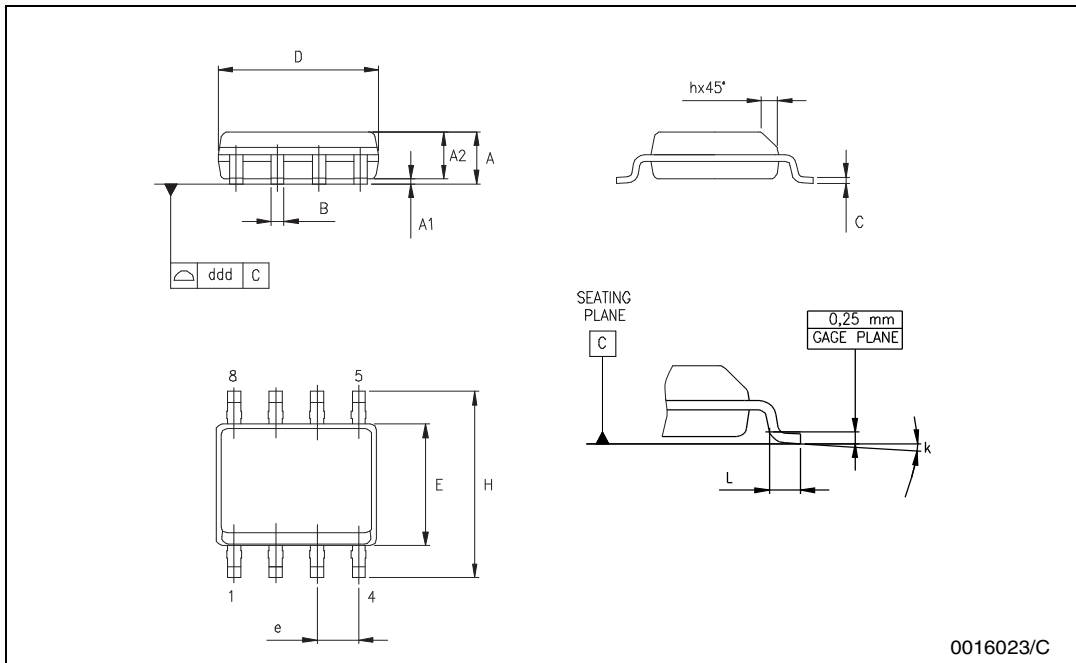

5.3 TSSOP8 package

TSSOP8 MECHANICAL DATA						
DIM.	mm.			inch		
	MIN.	TYP	MAX.	MIN.	TYP.	MAX.
A			1.2			0.047
A1	0.05		0.15	0.002		0.006
A2	0.80	1.00	1.05	0.031	0.039	0.041
b	0.19		0.30	0.007		0.012
c	0.09		0.20	0.004		0.008
D	2.90	3.00	3.10	0.114	0.118	0.122
E	6.20	6.40	6.60	0.244	0.252	0.260
E1	4.30	4.40	4.50	0.169	0.173	0.177
e		0.65			0.0256	
K	0°		8°	0°		8°
L	0.45	0.60	0.75	0.018	0.024	0.030
L1		1			0.039	

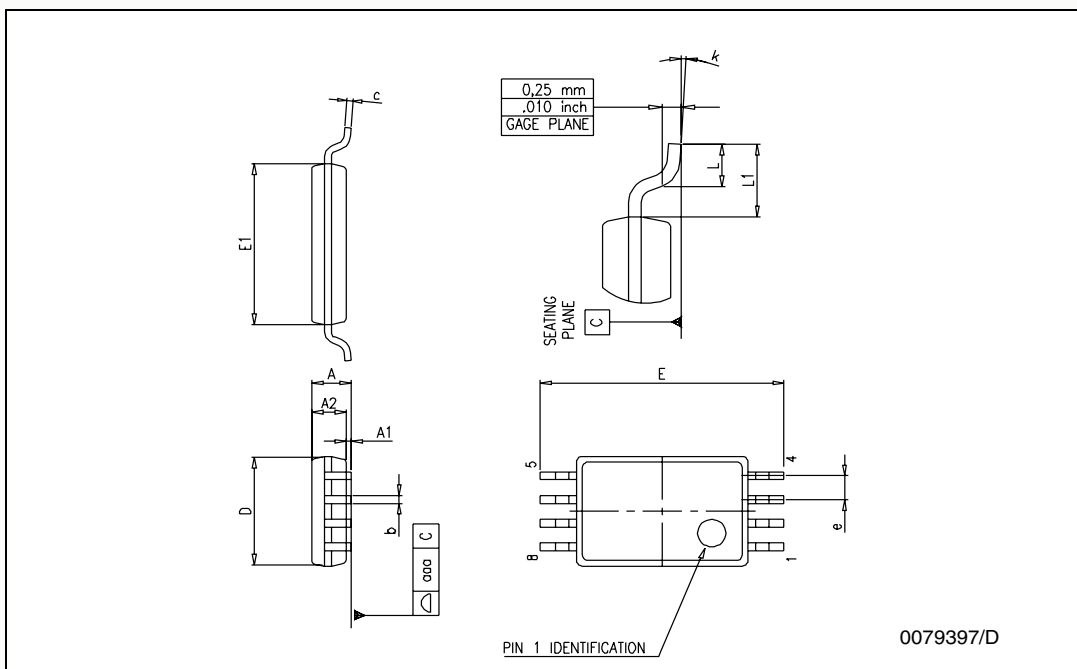

5.4 Mini SO8 package

miniSO-8 MECHANICAL DATA

DIM.	mm.			inch		
	MIN.	TYP	MAX.	MIN.	TYP.	MAX.
A			1.1			0.043
A1	0.05	0.10	0.15	0.002	0.004	0.006
A2	0.78	0.86	0.94	0.031	0.031	0.037
b	0.25	0.33	0.40	0.010	0.13	0.013
c	0.13	0.18	0.23	0.005	0.007	0.009
D	2.90	3.00	3.10	0.114	0.118	0.122
E	4.75	4.90	5.05	0.187	0.193	0.199
E1	2.90	3.00	3.10	.0114	0.118	0.122
e		0.65			0.026	
K	0°		6°	0°		6°
L	0.40	0.55	0.70	0.016	0.022	0.028
L1			0.10			0.004

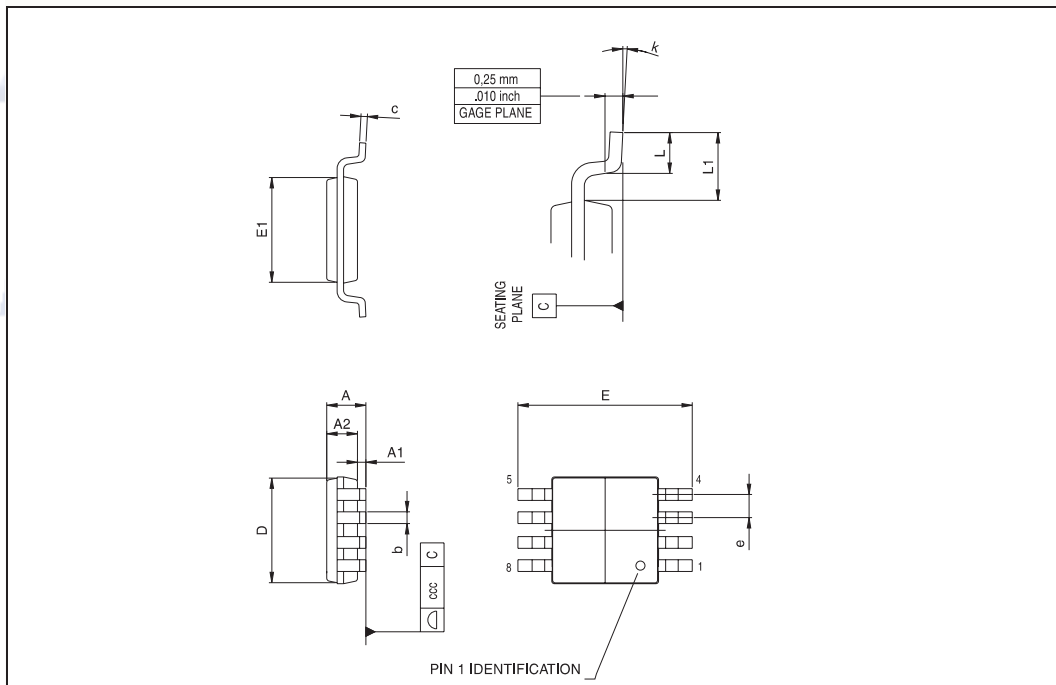

6 Revision History

Date	Revision	Description of Changes
July 2002	1	First Release
Jan. 2005	2	Class A of the product included in the datasheet.
May 2005	3	PPAP references inserted in the datasheet see table order code p1
July 2005	4	Modification on PPAP references - Errors on part numbers see table table order code p1.

Electrónica S.A. de C.V.

Information furnished is believed to be accurate and reliable. However, STMicroelectronics assumes no responsibility for the consequences of use of such information nor for any infringement of patents or other rights of third parties which may result from its use. No license is granted by implication or otherwise under any patent or patent rights of STMicroelectronics. Specifications mentioned in this publication are subject to change without notice. This publication supersedes and replaces all information previously supplied. STMicroelectronics products are not authorized for use as critical components in life support devices or systems without express written approval of STMicroelectronics.

The ST logo is a registered trademark of STMicroelectronics
All other names are the property of their respective owners

© 2005 STMicroelectronics - All rights reserved

STMicroelectronics group of companies

Australia - Belgium - Brazil - Canada - China - Czech Republic - Finland - France - Germany - Hong Kong - India - Israel - Italy - Japan - Malaysia - Malta - Morocco - Singapore - Spain - Sweden - Switzerland - United Kingdom - United States of America

www.st.com

