

QUAD 2-INPUT OR GATE

- HIGH SPEED
 $t_{PD} = 6 \text{ ns (TYP.) AT } V_{CC} = 5 \text{ V}$
- LOW POWER DISSIPATION
 $I_{CC} = 1 \mu\text{A (MAX.) AT } T_A = 25 \text{ }^\circ\text{C}$
- HIGH NOISE IMMUNITY
 $V_{NIH} = V_{NIL} = 28 \% V_{CC} \text{ (MIN.)}$
- OUTPUT DRIVE CAPABILITY
 10 LSTTL LOADS
- SYMMETRICAL OUTPUT IMPEDANCE
 $|I_{OH}| = I_{OL} = 4 \text{ mA (MIN.)}$
- BALANCED PROPAGATION DELAYS
 $t_{PLH} = t_{PHL}$
- WIDE OPERATING VOLTAGE RANGE
 $V_{CC} \text{ (OPR)} = 2 \text{ V TO } 6 \text{ V}$
- PIN AND FUNCTION COMPATIBLE WITH
 54/74LS32

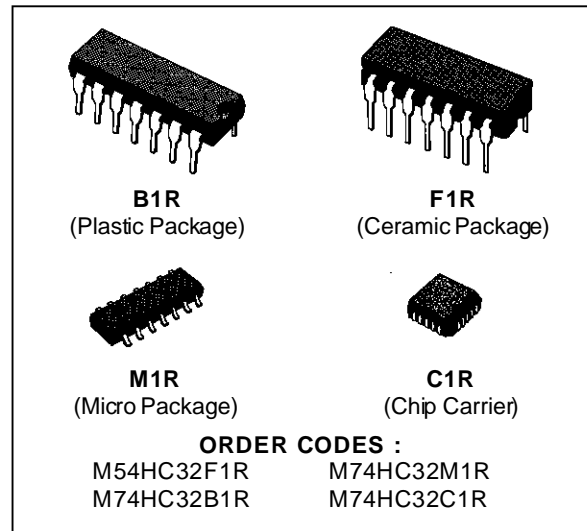

DESCRIPTION

The M54/74HC32 is a high speed CMOS 2-INPUT OR GATE fabricated in silicon gate C²MOS technology. It has the same high speed performance of LSTTL combined with true CMOS low power consumption. It achieves the high speed operation similar to equivalent LSTTL while maintaining the CMOS low power dissipation. The internal circuit is composed of 2 stages including buffered output, which gives high noise immunity and a stable output. All inputs are equipped with protection circuits against static discharge and transient excess voltage.

INPUT AND OUTPUT EQUIVALENT CIRCUIT

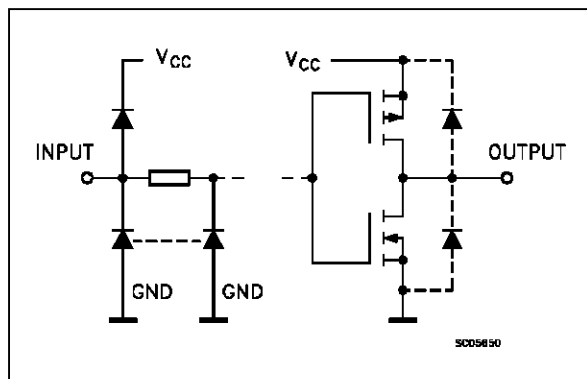

PIN CONNECTIONS (top view)

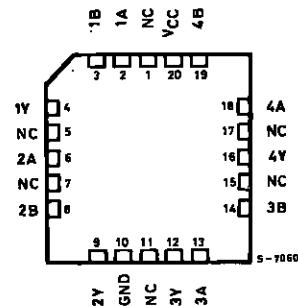
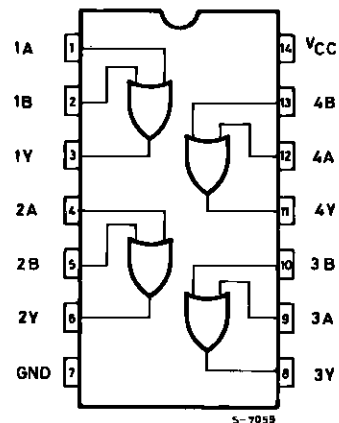

NC =
No Internal
Connection

M54/M74HC32

TRUTH TABLE

A	B	Y
L	L	L
L	H	H
H	L	H
H	H	H

IEC LOGIC SYMBOL

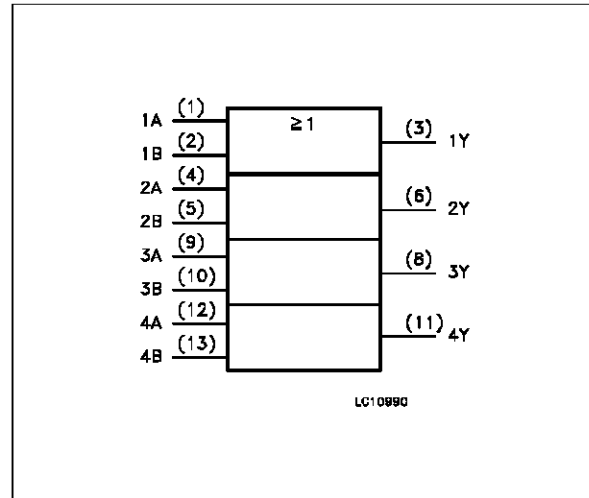

PIN DESCRIPTION

PIN No	SYMBOL	NAME AND FUNCTION
1, 4, 9, 12	1A to 4A	Data Inputs
2, 5, 10, 13	1B to 4B	Data Inputs
3, 6, 8, 11	1Y to 4Y	Data Outputs
7	GND	Ground (0V)
14	V _{CC}	Positive Supply Voltage

SCHEMATIC CIRCUIT (Per Gate)

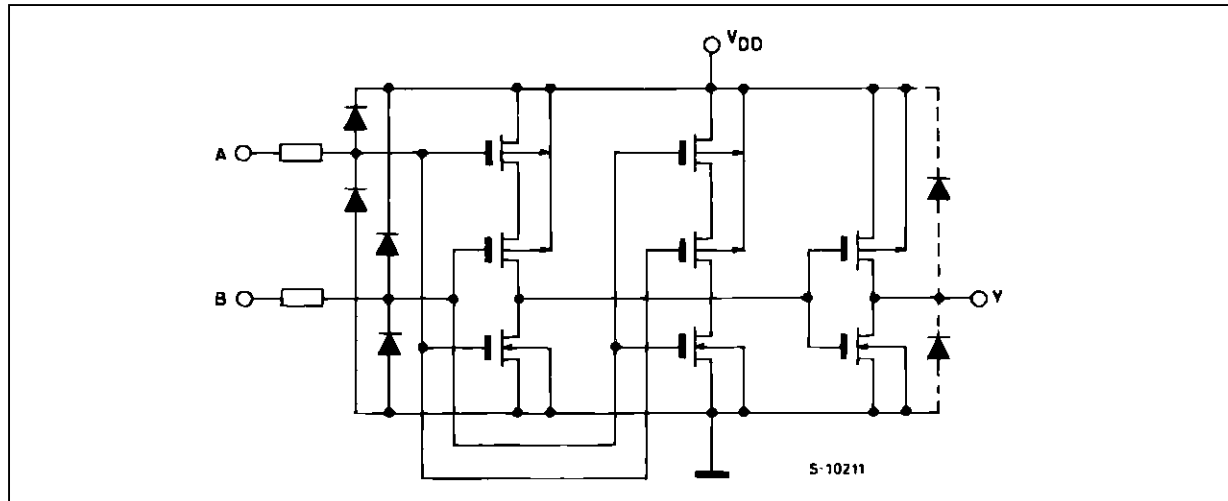

ABSOLUTE MAXIMUM RATINGS

Symbol	Parameter	Value	Unit
V _{CC}	Supply Voltage	-0.5 to +7	V
V _I	DC Input Voltage	-0.5 to V _{CC} + 0.5	V
V _O	DC Output Voltage	-0.5 to V _{CC} + 0.5	V
I _{IK}	DC Input Diode Current	± 20	mA
I _{OK}	DC Output Diode Current	± 20	mA
I _O	DC Output Source Sink Current Per Output Pin	± 25	mA
I _{CC} or I _{GND}	DC V _{CC} or Ground Current	± 50	mA
P _D	Power Dissipation	500 (*)	mW
T _{stg}	Storage Temperature	-65 to +150	°C
T _L	Lead Temperature (10 sec)	300	°C

Absolute Maximum Ratings are those values beyond which damage to the device may occur. Functional operation under these condition is not implied.

(*) 500 mW: ≅ 65 °C derate to 300 mW by 10mW/°C: 65 °C to 85 °C

RECOMMENDED OPERATING CONDITIONS

Symbol	Parameter	Value	Unit	
V_{CC}	Supply Voltage	2 to 6	V	
V_I	Input Voltage	0 to V_{CC}	V	
V_O	Output Voltage	0 to V_{CC}	V	
T_{op}	Operating Temperature: M54HC Series M74HC Series	-55 to +125 -40 to +85	$^{\circ}\text{C}$ $^{\circ}\text{C}$	
t_r, t_f	Input Rise and Fall Time	$V_{CC} = 2\text{ V}$ $V_{CC} = 4.5\text{ V}$ $V_{CC} = 6\text{ V}$	0 to 1000 0 to 500 0 to 400	ns

DC SPECIFICATIONS

Symbol	Parameter	Test Conditions		Value						Unit		
				$T_A = 25\text{ }^{\circ}\text{C}$ 54HC and 74HC			$-40\text{ to }85\text{ }^{\circ}\text{C}$ 74HC		$-55\text{ to }125\text{ }^{\circ}\text{C}$ 54HC			
				Min.	Typ.	Max.	Min.	Max.	Min.		Max.	
V_{IH}	High Level Input Voltage	V_{CC} (V)		1.5			1.5		1.5		V	
				3.15			3.15		3.15			
				4.2			4.2		4.2			
V_{IL}	Low Level Input Voltage	V_{CC} (V)				0.5		0.5		0.5	V	
						1.35		1.35		1.35		
						1.8		1.8		1.8		
V_{OH}	High Level Output Voltage	V_{CC} (V)	$V_I = V_{IH}$ or V_{IL}	$I_O = -20\text{ }\mu\text{A}$	1.9	2.0		1.9		1.9		V
					4.4	4.5		4.4		4.4		
					5.9	6.0		5.9		5.9		
				$I_O = -4.0\text{ mA}$	4.18	4.31		4.13		4.10		
					$I_O = -5.2\text{ mA}$	5.68	5.8		5.63		5.60	
V_{OL}	Low Level Output Voltage	V_{CC} (V)	$V_I = V_{IH}$ or V_{IL}	$I_O = 20\text{ }\mu\text{A}$		0.0	0.1		0.1		0.1	V
						0.0	0.1		0.1		0.1	
						0.0	0.1		0.1		0.1	
				$I_O = 4.0\text{ mA}$		0.17	0.26		0.33		0.40	
					$I_O = 5.2\text{ mA}$		0.18	0.26		0.33		
I_I	Input Leakage Current	6.0	$V_I = V_{CC}$ or GND			± 0.1		± 1		± 1	μA	
I_{CC}	Quiescent Supply Current	6.0	$V_I = V_{CC}$ or GND			1		10		20	μA	

M54/M74HC32

AC ELECTRICAL CHARACTERISTICS (C_L = 50 pF, Input t_r = t_f = 6 ns)

Symbol	Parameter	Test Conditions		Value						Unit	
		V _{CC} (V)		T _A = 25 °C 54HC and 74HC			-40 to 85 °C 74HC		-55 to 125 °C 54HC		
				Min.	Typ.	Max.	Min.	Max.	Min.		Max.
t _{TLH} t _{THL}	Output Transition Time	2.0			30	75		95		110	ns
		4.5			8	15		19		22	
		6.0			7	13		16		19	
t _{PLH} t _{PHL}	Propagation Delay Time	2.0			24	75		95		110	ns
		4.5			8	15		19		22	
		6.0			7	13		16		19	
C _{IN}	Input Capacitance				5	10		10		10	pF
C _{PD} (*)	Power Dissipation Capacitance				21						pF

(*) C_{PD} is defined as the value of the IC's internal equivalent capacitance which is calculated from the operating current consumption without load. (Refer to Test Circuit). Average operating current can be obtained by the following equation. I_{cc(opr)} = C_{PD} • V_{CC} • f_{IN} + I_{cc0}/4 (per Gate)

SWITCHING CHARACTERISTICS TEST CIRCUIT

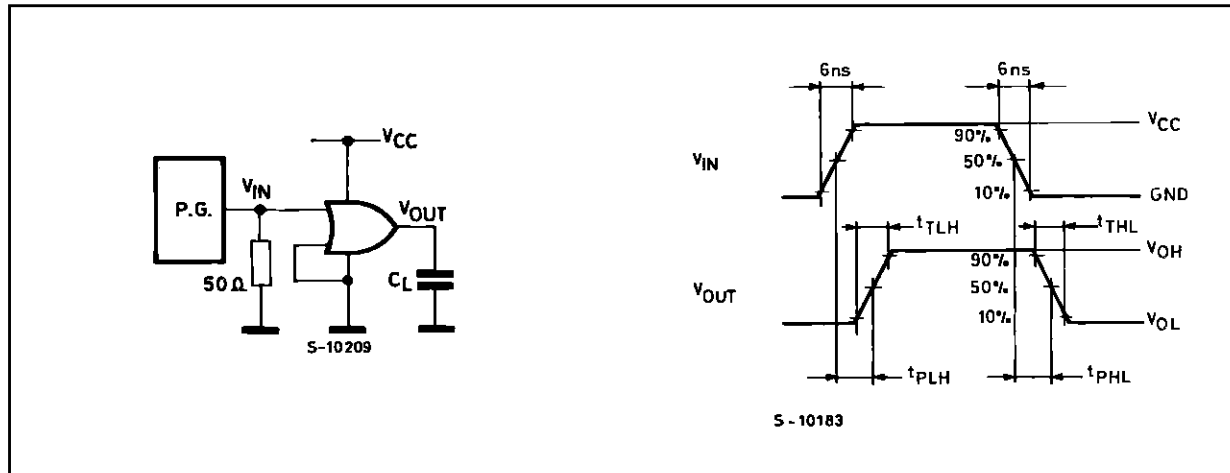

TEST CIRCUIT I_{cc} (Opr.)

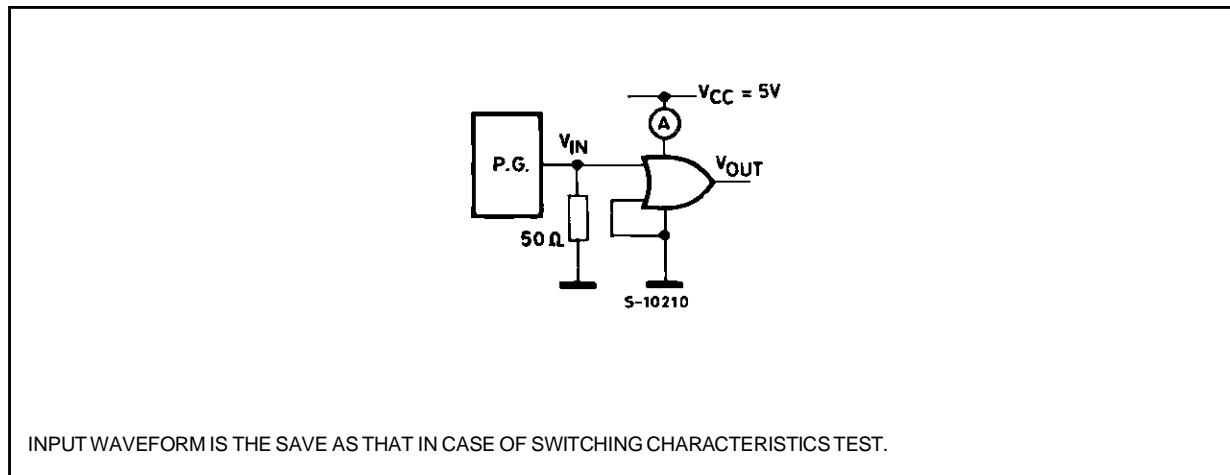

Plastic DIP14 MECHANICAL DATA

DIM.	mm			inch		
	MIN.	TYP.	MAX.	MIN.	TYP.	MAX.
a1	0.51			0.020		
B	1.39		1.65	0.055		0.065
b		0.5			0.020	
b1		0.25			0.010	
D			20			0.787
E		8.5			0.335	
e		2.54			0.100	
e3		15.24			0.600	
F			7.1			0.280
I			5.1			0.201
L		3.3			0.130	
Z	1.27		2.54	0.050		0.100

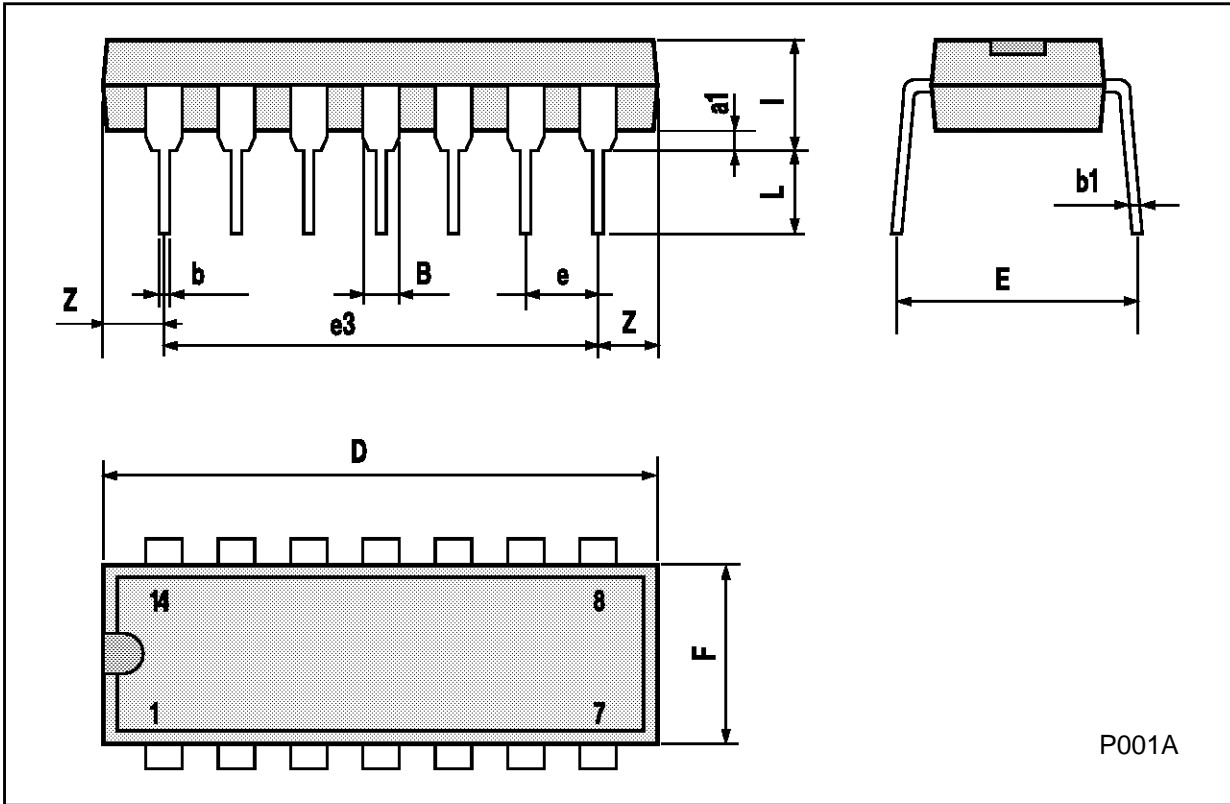

P001A

Ceramic DIP14/1 MECHANICAL DATA

DIM.	mm			inch		
	MIN.	TYP.	MAX.	MIN.	TYP.	MAX.
A			20			0.787
B			7.0			0.276
D		3.3			0.130	
E	0.38			0.015		
e3		15.24			0.600	
F	2.29		2.79	0.090		0.110
G	0.4		0.55	0.016		0.022
H	1.17		1.52	0.046		0.060
L	0.22		0.31	0.009		0.012
M	1.52		2.54	0.060		0.100
N			10.3			0.406
P	7.8		8.05	0.307		0.317
Q			5.08			0.200

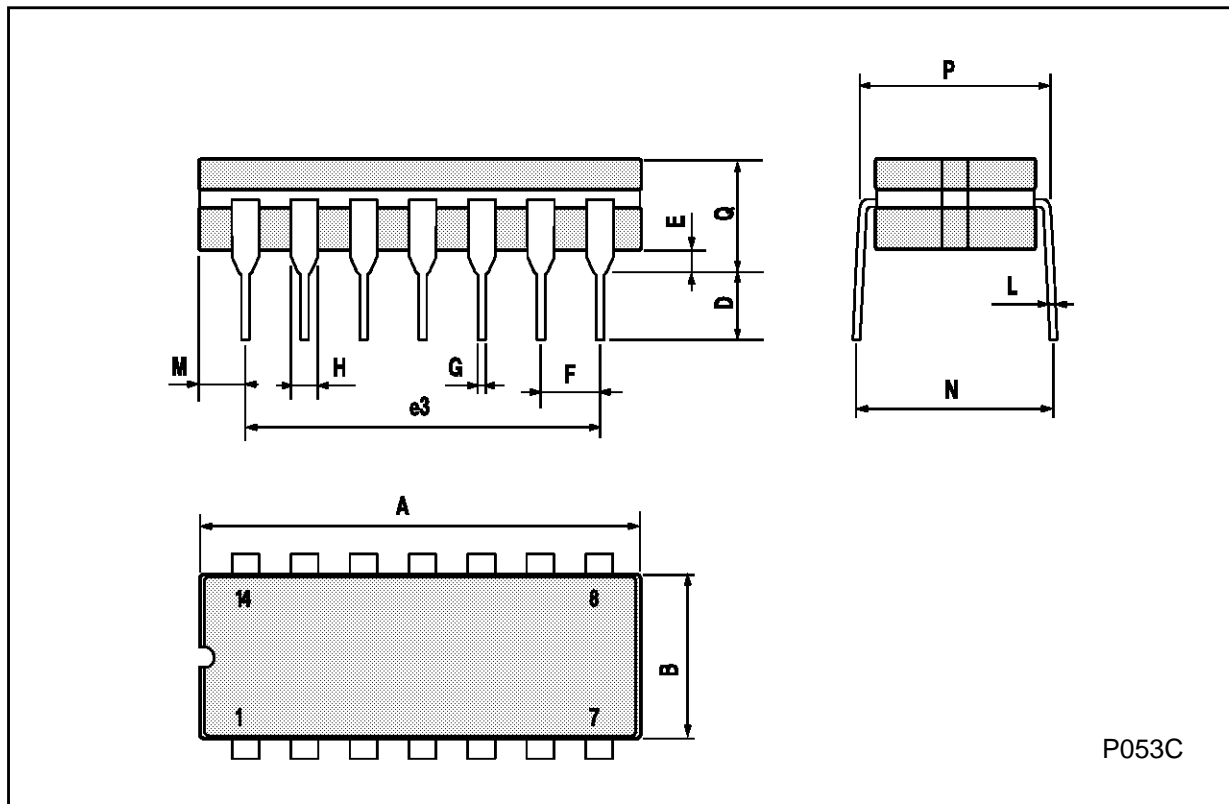

P053C

SO14 MECHANICAL DATA

DIM.	mm			inch		
	MIN.	TYP.	MAX.	MIN.	TYP.	MAX.
A			1.75			0.068
a1	0.1		0.2	0.003		0.007
a2			1.65			0.064
b	0.35		0.46	0.013		0.018
b1	0.19		0.25	0.007		0.010
C		0.5			0.019	
c1	45° (typ.)					
D	8.55		8.75	0.336		0.344
E	5.8		6.2	0.228		0.244
e		1.27			0.050	
e3		7.62			0.300	
F	3.8		4.0	0.149		0.157
G	4.6		5.3	0.181		0.208
L	0.5		1.27	0.019		0.050
M			0.68			0.026
S	8° (max.)					

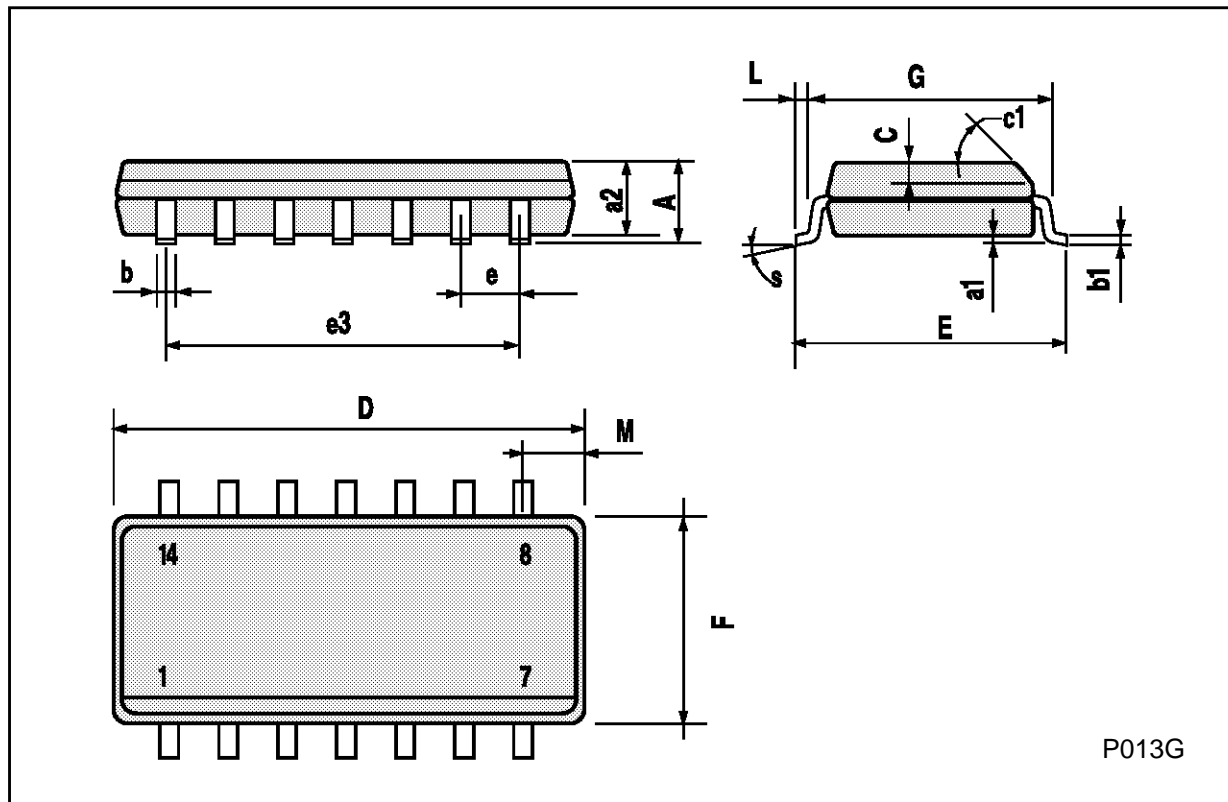

PLCC20 MECHANICAL DATA

DIM.	mm			inch		
	MIN.	TYP.	MAX.	MIN.	TYP.	MAX.
A	9.78		10.03	0.385		0.395
B	8.89		9.04	0.350		0.356
D	4.2		4.57	0.165		0.180
d1		2.54			0.100	
d2		0.56			0.022	
E	7.37		8.38	0.290		0.330
e		1.27			0.050	
e3		5.08			0.200	
F		0.38			0.015	
G			0.101			0.004
M		1.27			0.050	
M1		1.14			0.045	

