



NTE247 (NPN) & NTE248 (PNP) Silicon Complementary Transistors Darlington Power Amplifier

Description:

The NTE247 (NPN) and NTE248 (PNP) are silicon complementary Darlington transistors in a TO3 type case designed for general-purpose amplifier and low-frequency switching applications.

Features:

- High DC Current Gain: $h_{FE} = 3500$ Typ @ $I_C = 5A$
- Collector-Emitter Sustaining Voltage: $V_{CEO(sus)} = 100V$ Min @ 100mA
- Monolithic Construction with Built-In Base-Emitter Shunt Resistors

Absolute Maximum Ratings:

Collector-Emitter Voltage, V_{CEO}	100V
Collector-Base Voltage, V_{CB}	100V
Emitter-Base Voltage, V_{EB}	5V
Collector Current, I_C	
Continuous	12A
Peak	120A
Base Current, I_B	200mA
Total Power Dissipation ($T_C = +25^\circ C$), P_D	150W
Derate Above $25^\circ C$	0.857W/ $^\circ C$
Operating Junction Temperature Range, T_J	-65° to $+200^\circ C$
Storage Temperature Range, T_{stg}	-65° to $+200^\circ C$
Thermal Resistance, Junction-to-Case, R_{thJC}	1.17 $^\circ C/W$

Electrical Characteristics: ($T_C = +25^\circ C$ unless otherwise specified)

Parameter	Symbol	Test Conditions	Min	Typ	Max	Unit
OFF Characteristics						
Collector-Emitter Sustaining Voltage	$V_{CEO(sus)}$	$I_C = 100mA, I_B = 0$, Note 1	100	–	–	V
Collector Cutoff Current	I_{CEO}	$V_{CE} = 50V, I_E = 0$	–	–	1.0	mA
		$V_{CE} = 100V, V_{BE(off)} = 1.5V$	–	–	0.5	mA
	$V_{CE} = 100V, V_{BE(off)} = 1.5V, T_A = +150^\circ C$	–	–	5.0	mA	
Emitter Cutoff Current	I_{EBO}	$V_{BE} = 5V, I_C = 0$	–	–	2.0	mA

Note 1. Pulse Test: Pulse Width = 300 μs , Duty Cycle = 2%

Electrical Characteristics (Cont'd): ($T_A = +25^\circ\text{C}$ unless otherwise specified)

Parameter	Symbol	Test Conditions	Min	Typ	Max	Unit
ON Characteristics (Note 1)						
DC Current Gain	h_{FE}	$V_{CE} = 3\text{V}, I_C = 6\text{A}$	750	-	18000	
		$V_{CE} = 3\text{V}, I_C = 12\text{A}$	100	-	-	
Collector-Emitter Saturation Voltage	$V_{CE(sat)}$	$I_C = 6\text{A}, I_B = 24\text{mA}$	-	-	2.0	V
		$I_C = 12\text{A}, I_B = 120\text{mA}$	-	-	3.0	V
Base-Emitter Saturation Voltage	$V_{BE(sat)}$	$I_C = 12\text{A}, I_B = 120\text{mA}$	-	-	4.0	V
Base-Emitter ON Voltage	$V_{BE(on)}$	$V_{CE} = 3\text{V}, I_C = 6\text{A}$	-	-	2.8	V
Dynamic Characteristics						
Small-Signal Current Gain	h_{fe}	$V_{CE} = 3\text{V}, I_C = 5\text{A}, f = 1\text{kHz}$	300	-	-	
Magnitude of Common Emitter Small-Signal Short-Circuit Forward Current Transfer Ratio	$ h_{fe} $	$V_{CE} = 3\text{V}, I_C = 5\text{A}, f = 1\text{MHz}$	4.0	-	-	MHz
Output Capacitance NTE247	C_{ob}	$V_{CB} = 10\text{V}, I_E = 0, f = 0.1\text{MHz}$	-	-	300	pF
			NTE248	-	-	500

Note 1. Pulse Test: Pulse Width = 300 μs , Duty Cycle = 2%

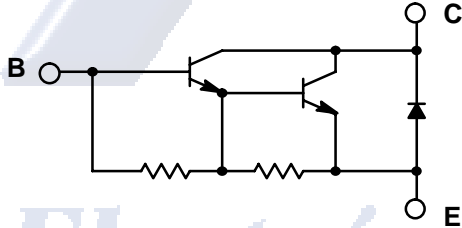
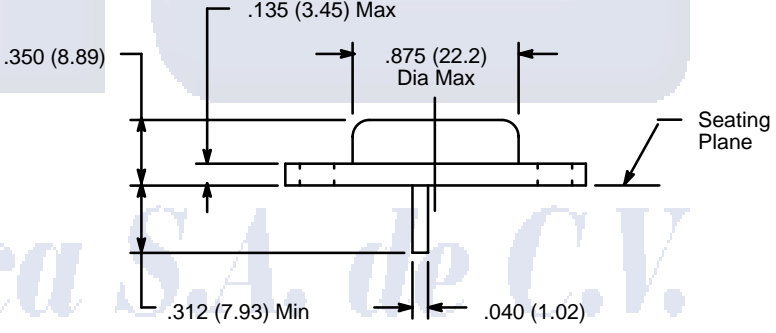
<p>NTE247</p> 	
<p>NTE248</p> 