



# RC4136

## General Performance Quad 741 Operational Amplifier

### Features

- Unity gain bandwidth – 3 MHz
- Short circuit protection
- No frequency compensation required
- No latch-up
- Large common mode and differential voltage ranges
- Low power consumption
- Parameter tracking over temperature range
- Gain and phase match between amplifiers

### Description

The RC4136 is made up of four 741 type independent high gain operational amplifiers internally compensated and constructed on a single silicon chip using the planar epitaxial process.

This amplifier meets or exceeds all specifications for 741 type amplifiers. Excellent channel separation allows the use

of the RC4136 quad amplifier in all 741 operational amplifier applications providing the highest possible packaging density.

The specially designed low noise input transistors allow the RC4136 to be used in low noise signal processing applications such as audio preamplifiers and signal conditioners.

### Block Diagram

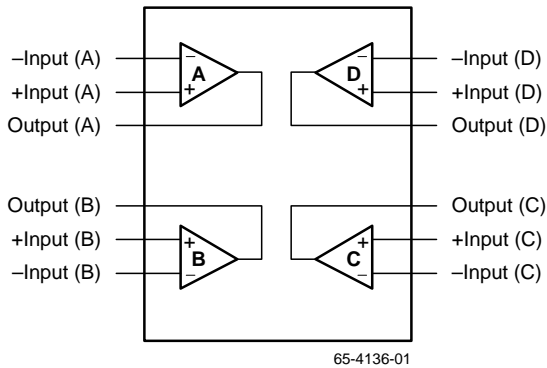

### Pin Assignments

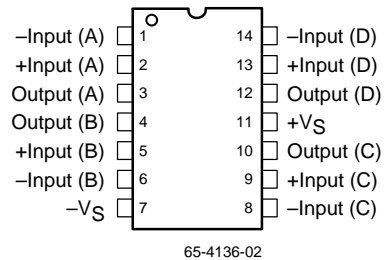

## Absolute Maximum Ratings

(beyond which the device may be damaged)<sup>1</sup>

Parameter		Min	Typ	Max	Units
Supply Voltage	RC4136			±18	V
	RM4136			±22	V
Input Voltage <sup>2</sup>				±30	V
Differential Input Voltage				30	V
Output Short Circuit Duration <sup>3</sup>		Indefinite			
P <sub>DTA</sub> < 50°C	SOIC			300	mW
	PDIP			468	mW
	CerDIP			1042	mW
Operating Temperature	RC4136	0		70	°C
	RM4136	-55		125	°C
Storage Temperature		-65		150	°C
Junction Temperature	SOIC, PDIP			125	°C
	CerDIP			175	°C
Lead Soldering Temperature (60 seconds)	DIP			300	°C
	SOIC			260	°C

### Notes:

- Functional operation under any of these conditions is NOT implied. Performance and reliability are guaranteed only if Operating Conditions are not exceeded.
- For supply voltages less than ±15V, the absolute maximum input voltage is equal to the supply voltage.
- Short circuit may be to ground, typically 45 mA.

## Operating Conditions

Parameter		Min	Typ	Max	Units
θ <sub>JC</sub>	Thermal resistance		60		°C/W
θ <sub>JA</sub>	Thermal resistance	SOIC	200		°C/W
		PDIP	160		°C/W
		CerDIP	120		°C/W
For T <sub>A</sub> > 50°C Derate at			5.0		mW/°C

## Electrical Characteristics

( $V_S = \pm 15V$  and  $T_A = +25^\circ C$ , unless otherwise noted)

Parameters	Test Conditions	RM4136			RC4136			Units
		Min	Typ	Max	Min	Typ	Max	
Input Offset Voltage	$R_S \leq 10k\Omega$		0.5	5.0		0.5	6.0	mV
Input Offset Current			5.0	200		5.0	200	nA
Input Bias Current			40	500		40	500	nA
Input Resistance		0.3	5.0		0.3	5.0		$M\Omega$
Large Signal Voltage Gain	$R_L \geq 2k\Omega$ , $V_{OUT} = \pm 10V$	50	300		20	300		V/mV
Output Voltage Swing	$R_L \geq 10k\Omega$	$\pm 12$	$\pm 14$		$\pm 12$	$\pm 14$		V
	$R_L \geq 2k\Omega$	$\pm 10$	$\pm 13$		$\pm 10$	$\pm 13$		
Input Voltage Range		$\pm 12$	$\pm 14$		$\pm 12$	$\pm 14$		V
Common Mode Rejection Ratio	$R_S \leq 10k\Omega$	70	100		70	100		dB
Power Supply Rejection Ratio	$R_S \leq 10k\Omega$	76	100		76	100		dB
Power Consumption	$R_L = \infty$ , All Outputs		210	340		210	340	mW
Transient Response								
Rise Time	$V_{IN} = 20mV$ , $R_L = 2k\Omega$		0.13			0.13		$\mu S$
Overshoot	$C_L \leq 100pF$		5.0			5.0		%
Unity Gain Bandwidth			3.0			3.0		MHz
Slew Rate	$R_L \geq 2k\Omega$		1.5			1.0		V/ $\mu S$
Channel Separation	$F = 1.0kHz$ , $R_S = 1k\Omega$		90			90		dB

## Electrical Characteristics

( $R_M = -55^\circ C \leq T_A \leq 125^\circ$ ,  $R_C = 0^\circ C \leq T_A \leq 70^\circ$ ,  $V_S = \pm 15V$ )

Parameters	Test Conditions	RM4136			RC4136			Units
		Min	Typ	Max	Min	Typ	Max	
Input Offset Voltage	$R_S \leq 10k\Omega$			6.0			7.5	mV
Input Offset Current				500			300	nA
Input Bias Current				1500			800	nA
Large Signal Voltage Gain	$R_L \geq 2k\Omega$ , $V_{OUT} = \pm 10V$	25			15			V/mV
Output Voltage Swing	$R_L \geq 2k\Omega$	$\pm 10$			$\pm 10$			V
Power Consumption			240	400		240	400	mW

## Electrical Characteristics Comparison

( $V_S = \pm 15V$  and  $T_A +25^\circ C$  unless otherwise noted)

Parameter	RC4136 (Typ.)	RC741 (Typ.)	LM324 (Typ.)	Units
Input Offset Voltage	0.5	2.0	2.0	mV
Input Offset Current	5.0	10	5.0	nA
Input Bias Current	40	80	55	nA
Input Resistance	5.0	2.0		M $\Omega$
Large Signal Voltage Gain ( $R_L = 2k\Omega$ )	300	200	100	V/mV
Output Voltage Swing ( $R_L = 2k\Omega$ )	$\pm 13V$	$\pm 13V$	$ +V_S - 1.2V $ to $-V_S$	V
Input Voltage Range	$\pm 14V$	$\pm 13V$	$ +V_S - 1.5V $ to $-V_S$	V
Common Mode Rejection Ratio	100	90	85	dB
Power Supply Rejection Ratio	100	90	100	dB
Transient Response				
Rise Time	0.13	0.3		$\mu S$
Overshoot	5.0	5.0		%
Unity Gain Bandwidth	3.0	0.8	0.8	MHz
Slew Rate	1.0	0.5	0.5	V/ $\mu S$
Input Noise Voltage Density (F= 1kHz)	10	22.5		nV/ $\sqrt{Hz}$
Short Circuit Current	$\pm 45$	$\pm 25$		mA

*Electrónica S.A. de C.V.*

### Typical Performance Characteristics

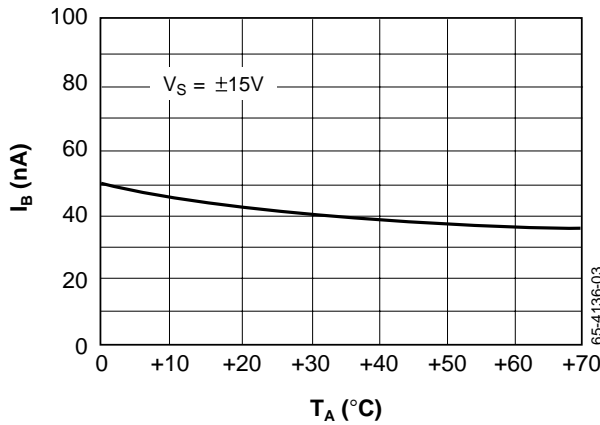

Figure 1. Input Bias Current vs. Temperature

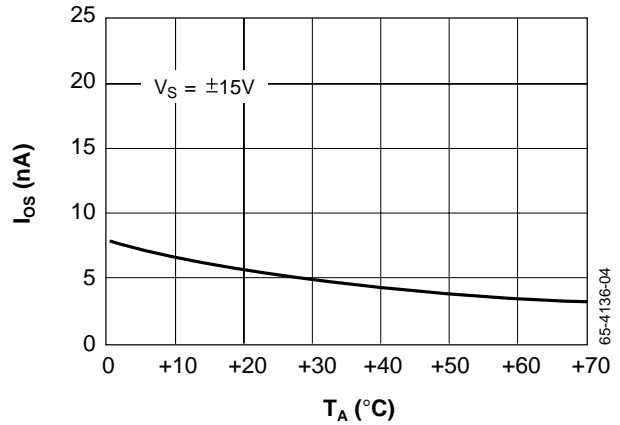

Figure 2. Input Offset Current vs. Temperature

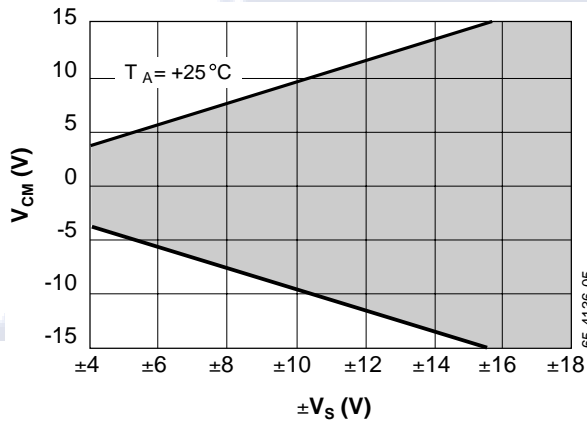

Figure 3. Input Common Mode Voltage Range vs. Supply Voltage

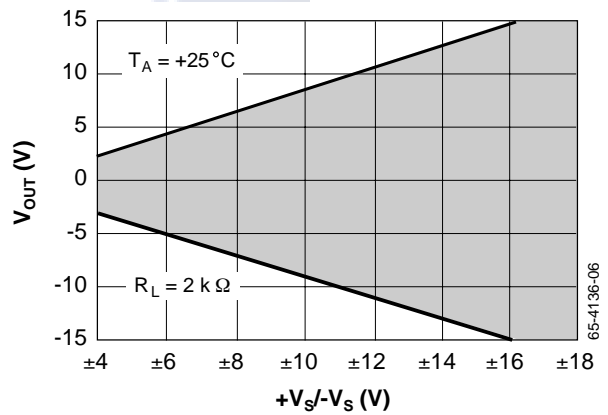

Figure 4. Output Voltage vs. Supply Voltage

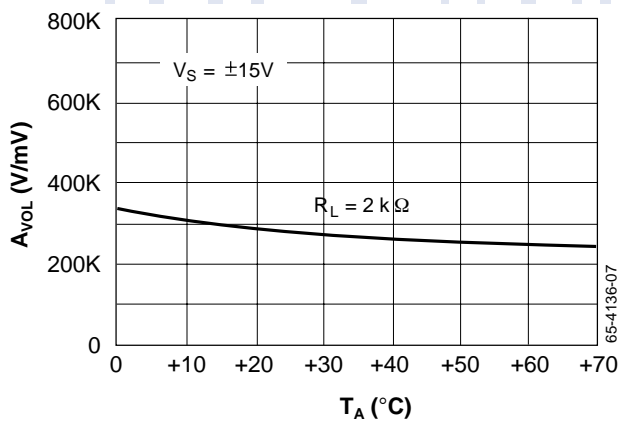

Figure 5. Open Loop Gain vs. Temperature

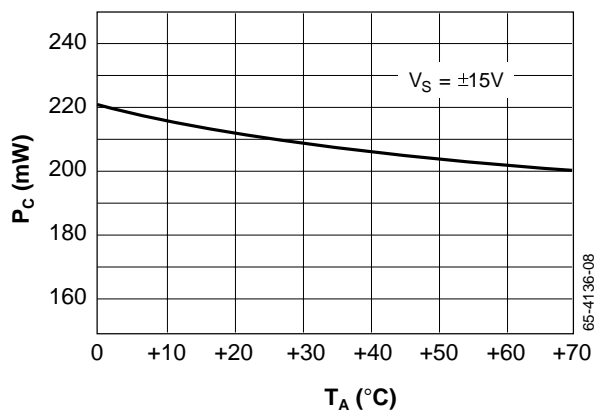

Figure 6. Power Consumption vs. Temperature

Typical Performance Characteristics (continued)

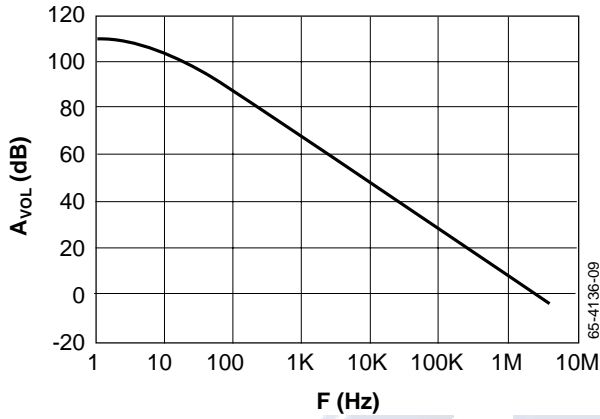

Figure 7. Open Loop Gain vs. Frequency

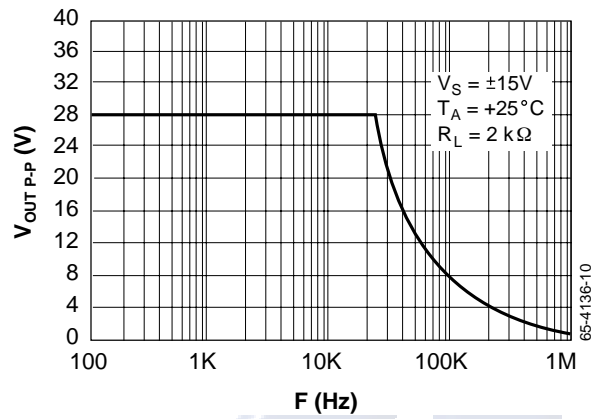

Figure 8. Output Voltage Swing vs. Frequency

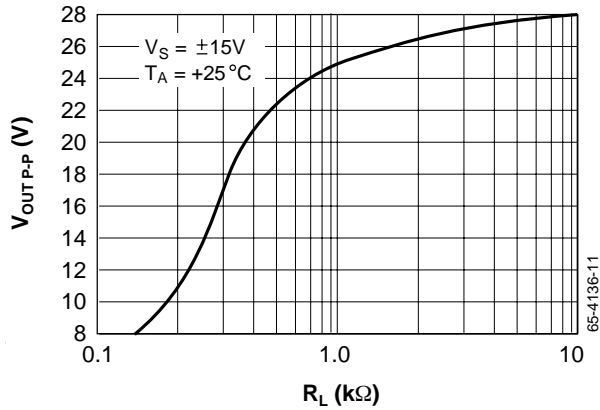

Figure 9. Output Voltage Swing vs. Load Resistance

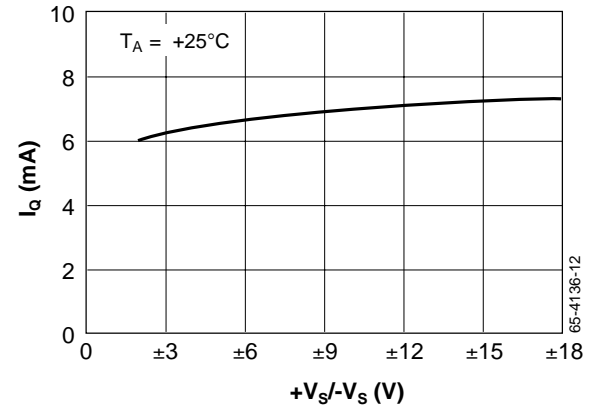

Figure 10. Quiescent Current vs. Supply Voltage

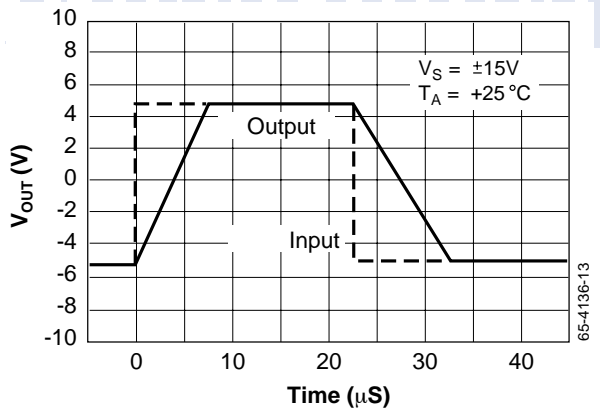

Figure 11. Follower Large Signal Pulse Response

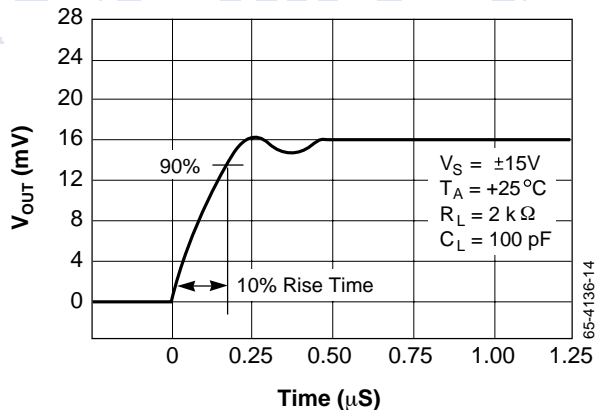

Figure 12. Transient Response Output Voltage vs. Time

### Typical Performance Characteristics (continued)

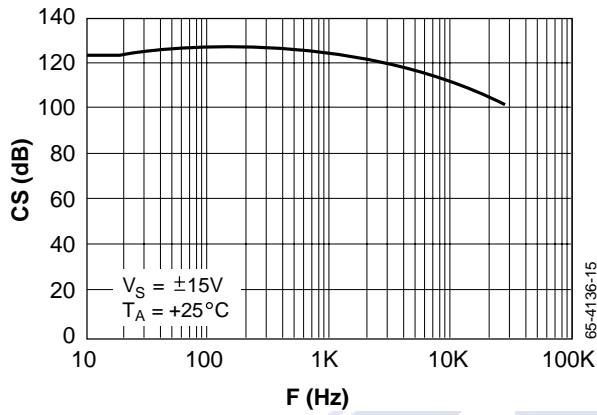

Figure 13. Channel Separation vs. Frequency

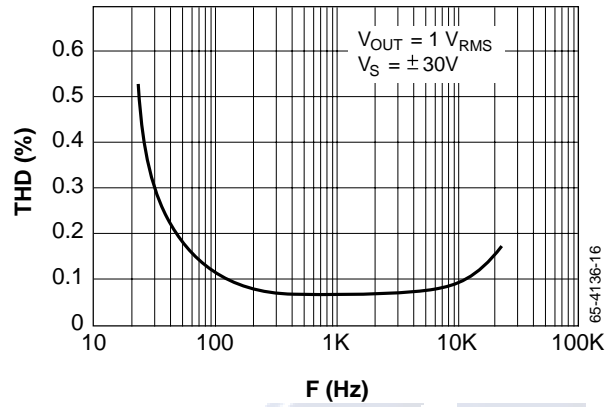

Figure 14. Total Harmonic Distortion vs. Frequency

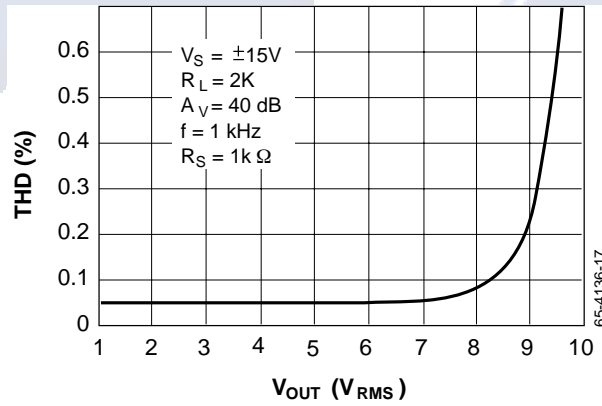

Figure 15. Total Harmonic Distortion vs. Output Voltage

*Electrónica S.A. de C.V.*

## RC4136 Versus LM324

Although the LM324 is an excellent device for single-supply applications where ground sensing is important, it is a poor substitute for four 741s in split supply circuits. The simplified input circuit of the RC4136 exhibits much lower noise

than that of the LM324 and exhibits no crossover distortion as compared with the LM324 (see Figure 16). The LM324 shows significant crossover distortion and pulse delay in attempting to handle a large signal input pulse.

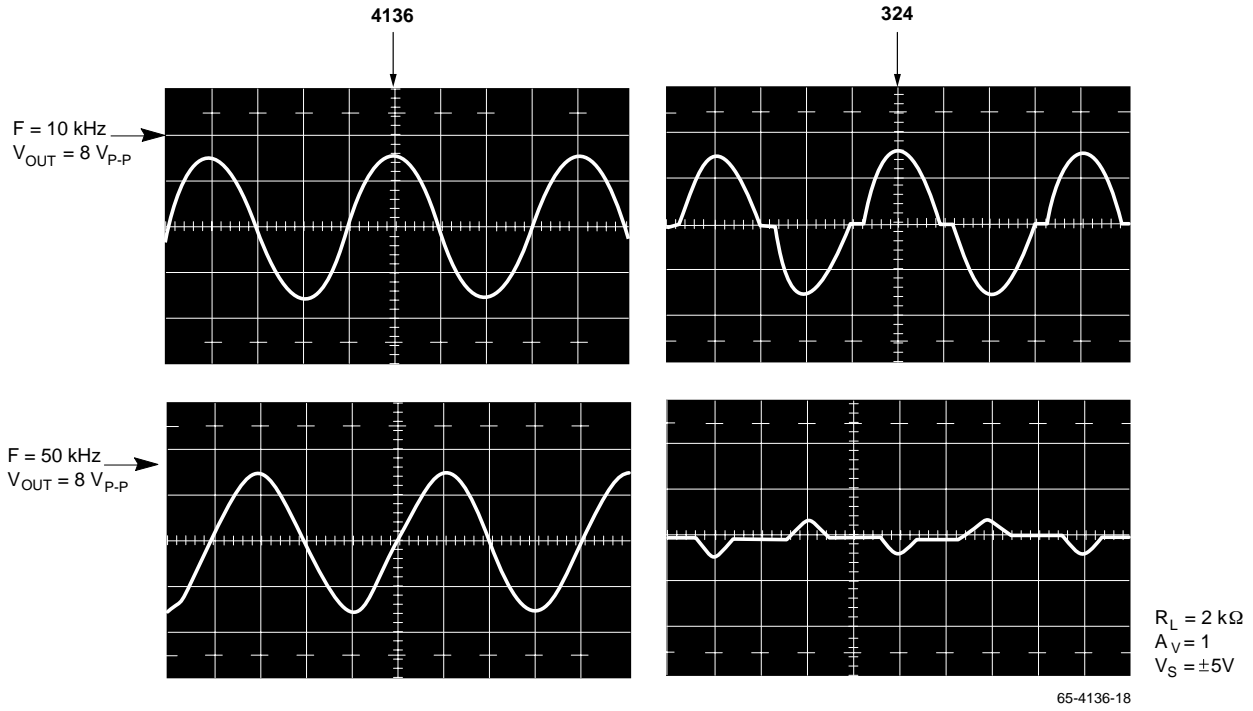

Figure 16. Comparative Crossover Distortion

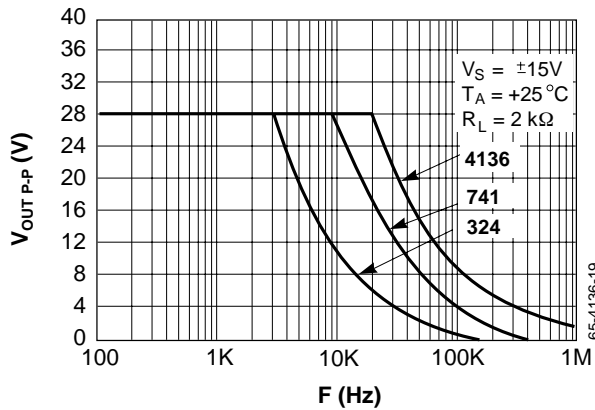

Figure 17. Output Voltage Swing vs. Frequency

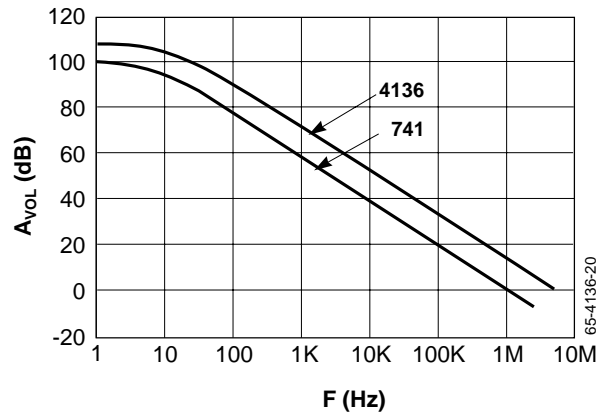

Figure 18. Open Loop Gain vs. Frequency



RC4136 Versus LM324 (continued)

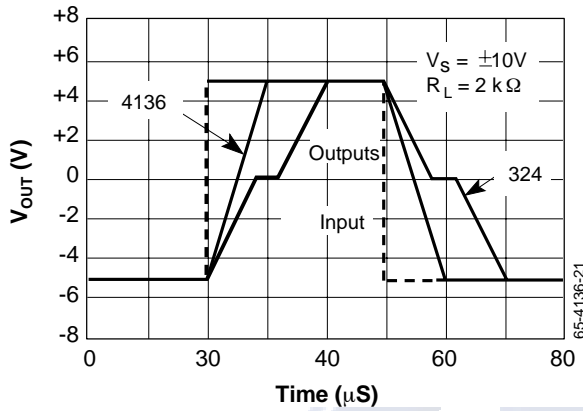

Figure 19. Follower Large Signal Pulse Response Output Voltage vs. Time

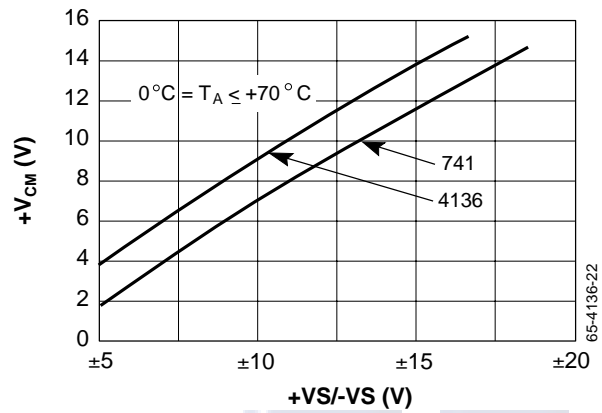

Figure 20. Input Common Mode Voltage Range vs. Supply Voltage

Typical Applications

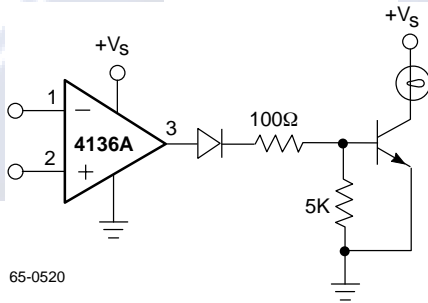

Figure 21. Lamp Driver

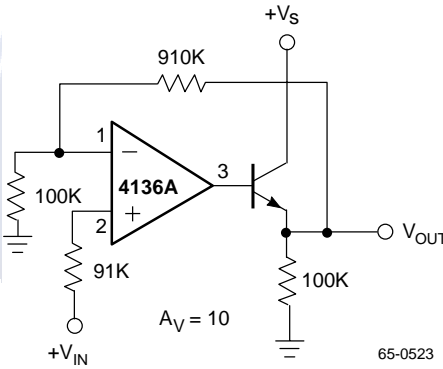

Figure 22. Power Amplifier

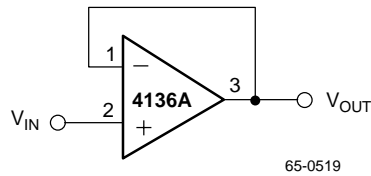

Figure 23. Voltage Follower

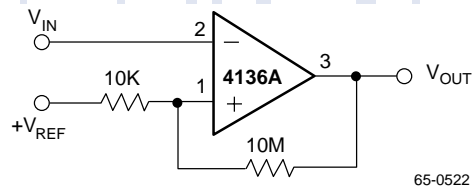

Figure 24. Comparator with Hysteresis

Electronica S.A. de C.V.

Typical Applications (continued)

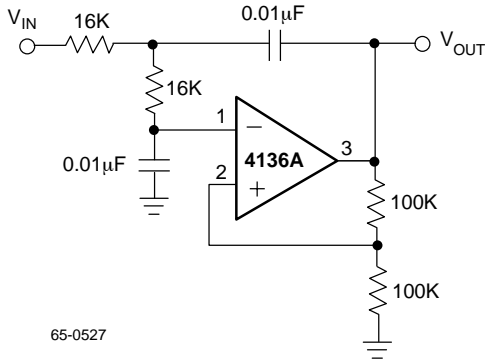

Figure 25. DC Coupled 1kHz Lowpass Active Filter

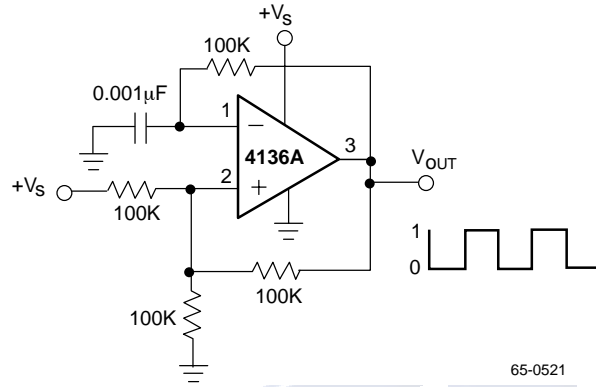

Figure 26. Squarewave Oscillator

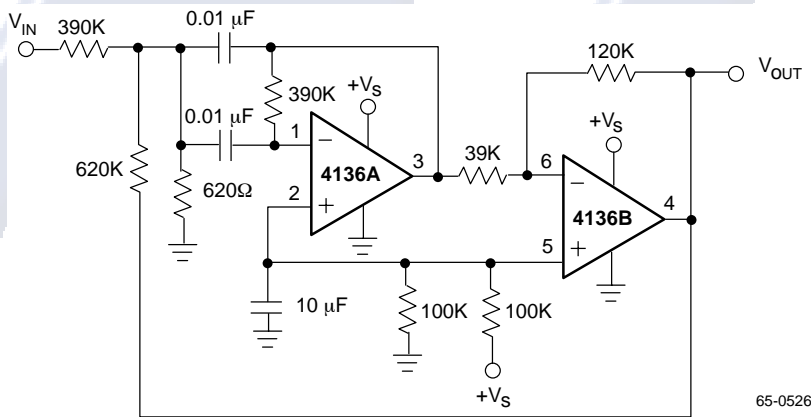

Figure 27. 1kHz Bandpass Active Filter

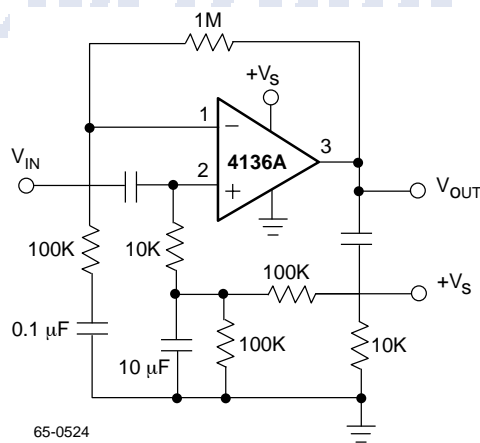

Figure 28. AC Coupled Non-Inverting Amplifier

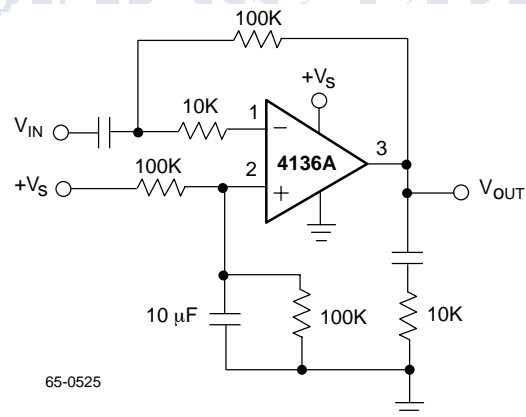
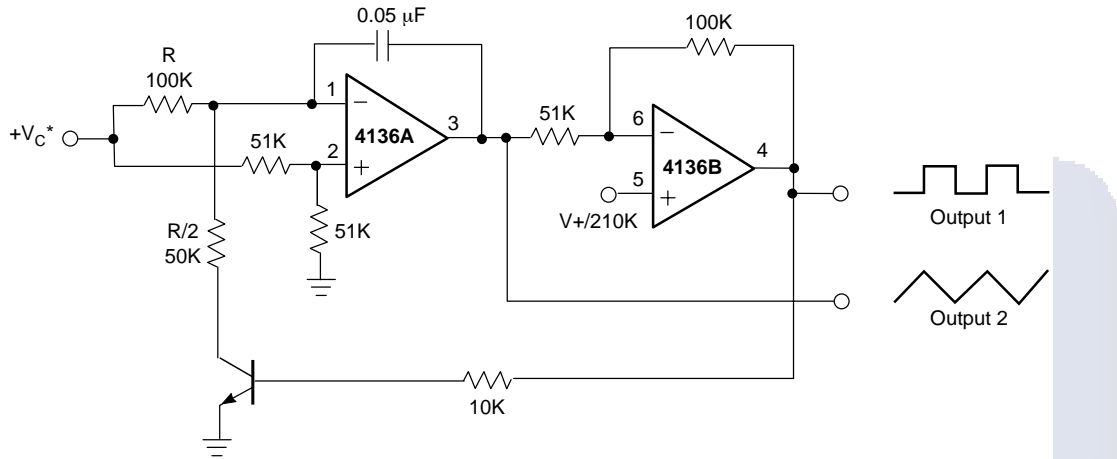

Figure 29. AC Coupled Inverting Amplifier

Typical Applications (continued)



\* Wide control voltage range:  $0V < V_C < 2(+V_S - 1.5V)$

65-0528

Figure 30. Voltage Control Oscillator (VCO)

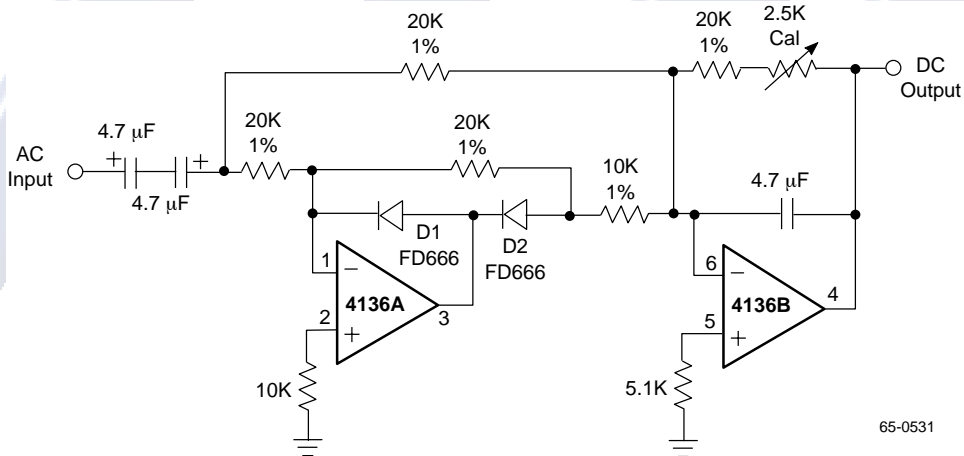

65-0531

Figure 31. Full-Wave Rectifier and Averaging Filter

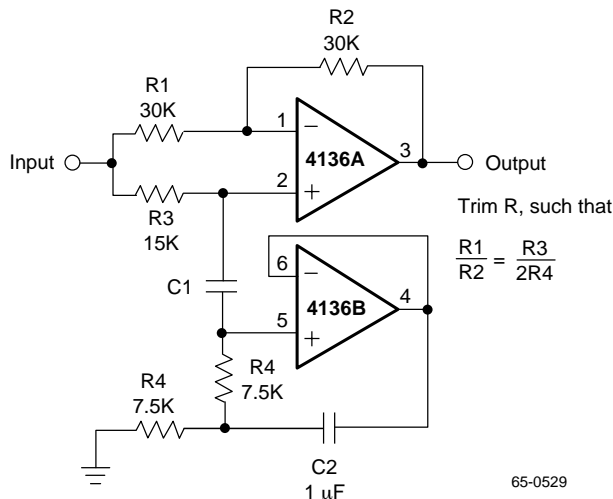

65-0529

Figure 32. Notch Filter Using the RC4136 as a Gyrator

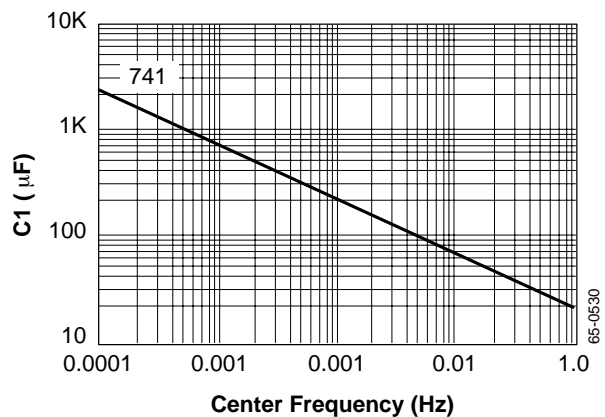

65-0530

Figure 33. Notch Frequency vs. C1

Typical Applications (continued)

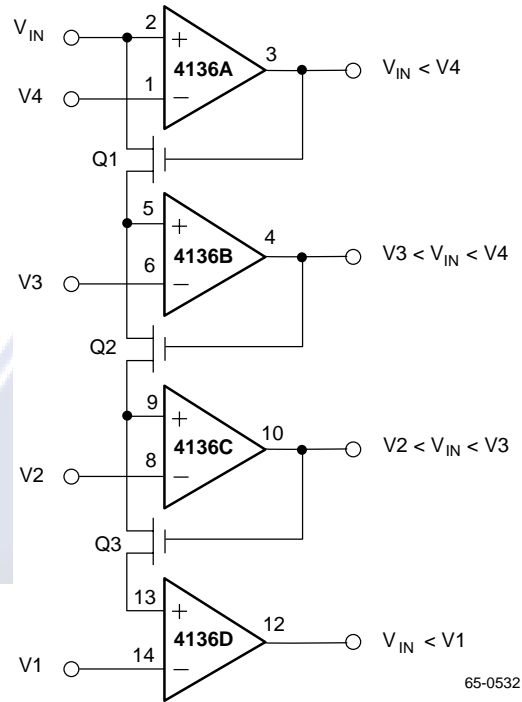

Figure 34. Multiple Aperture Window Discriminator

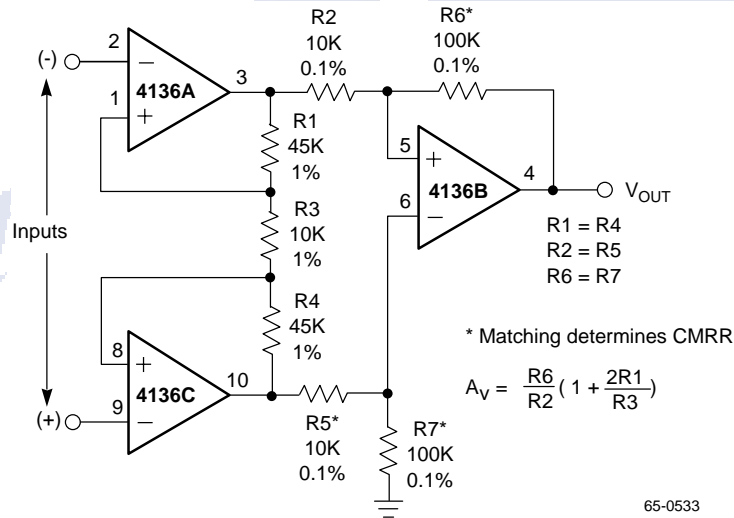
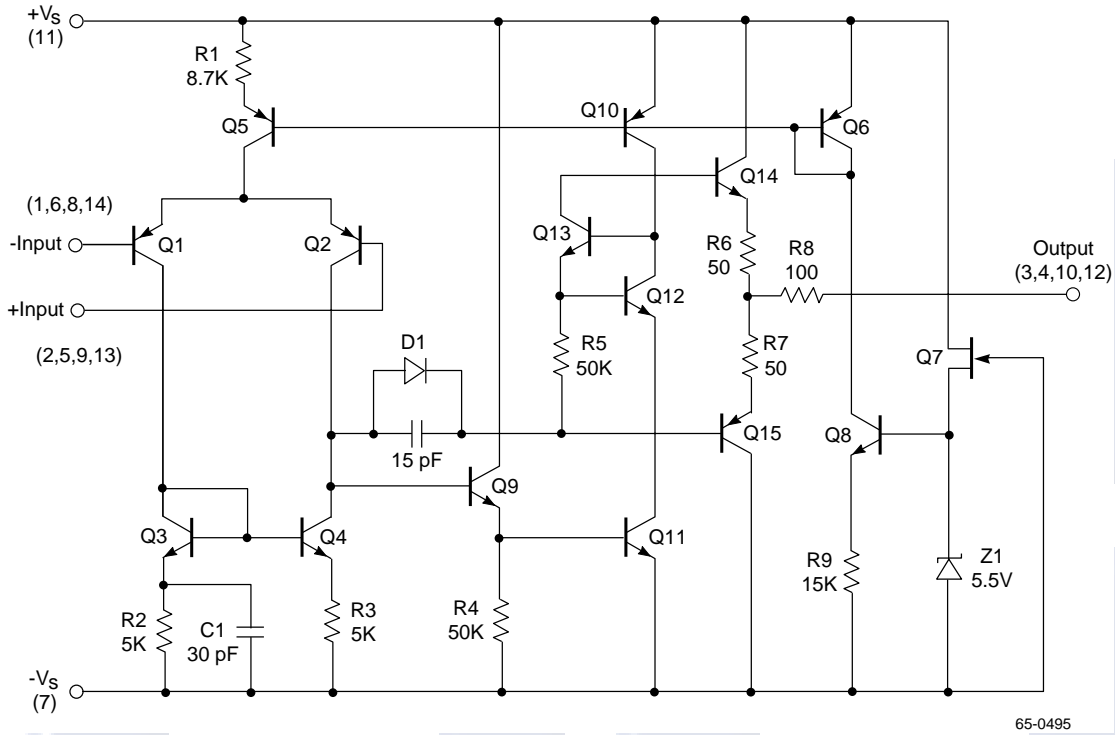

Figure 35. Differential Input Instrumentation Amplifier with High Common Mode Rejection



### Simplified Schematic Diagram



*Electrónica S.A. de C.V.*

# Mechanical Dimensions

## 14-Lead Ceramic DIP Package

Symbol	Inches		Millimeters		Notes
	Min.	Max.	Min.	Max.	
A	—	.200	—	5.08	
b1	.014	.023	.36	.58	8
b2	.045	.065	1.14	1.65	2
c1	.008	.015	.20	.38	8
D	—	.785	—	19.94	4
E	.220	.310	5.59	7.87	4
e	.100 BSC		2.54 BSC		5, 9
eA	.300 BSC		7.62 BSC		7
L	.125	.200	3.18	5.08	
Q	.015	.060	.38	1.52	3
s1	.005	—	.13	—	6
$\alpha$	90°	105°	90°	105°	

**Notes:**

1. Index area: a notch or a pin one identification mark shall be located adjacent to pin one. The manufacturer's identification shall not be used as pin one identification mark.
2. The minimum limit for dimension "b2" may be .023 (.58mm) for leads number 1, 7, 8 and 14 only.
3. Dimension "Q" shall be measured from the seating plane to the base plane.
4. This dimension allows for off-center lid, meniscus and glass overrun.
5. The basic pin spacing is .100 (2.54mm) between centerlines. Each pin centerline shall be located within  $\pm .010$  (.25mm) of its exact longitudinal position relative to pins 1 and 14.
6. Applies to all four corners (leads number 1, 7, 8, and 14).
7. "eA" shall be measured at the center of the lead bends or at the centerline of the leads when " $\alpha$ " is 90°.
8. All leads – Increase maximum limit by .003 (.08mm) measured at the center of the flat, when lead finish applied.
9. Twelve spaces.

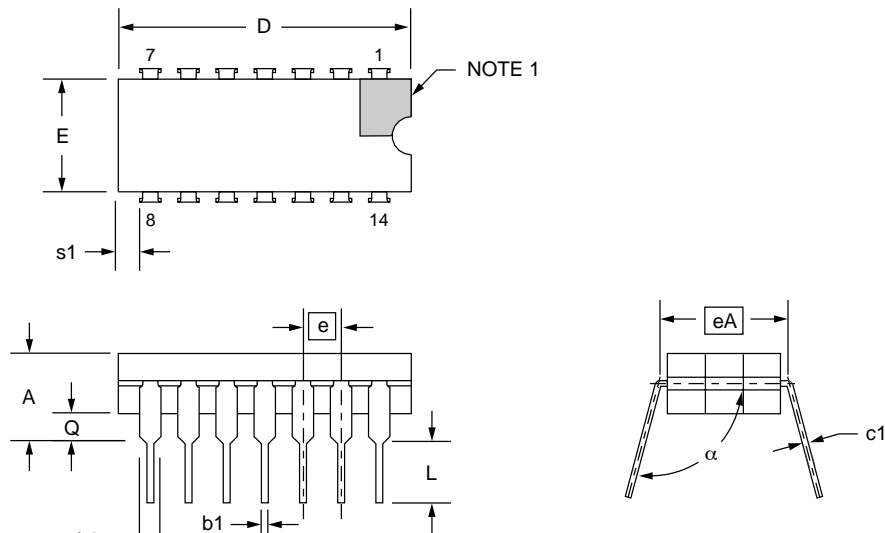

## Mechanical Dimensions (continued)

### 14-Lead Plastic DIP Package

Symbol	Inches		Millimeters		Notes
	Min.	Max.	Min.	Max.	
A	—	.210	—	5.33	
A1	.015	—	.38	—	
A2	.115	.195	2.93	4.95	
B	.014	.022	.36	.56	
B1	.045	.070	1.14	1.78	
C	.008	.015	.20	.38	4
D	.725	.795	18.42	20.19	2
D1	.005	—	.13	—	
E	.300	.325	7.62	8.26	
E1	.240	.280	6.10	7.11	2
e	.100 BSC		2.54 BSC		
eB	—	.430	—	10.92	
L	.115	.200	2.92	5.08	
N	14		14		5

#### Notes:

1. Dimensioning and tolerancing per ANSI Y14.5M-1982.
2. "D" and "E1" do not include mold flashing. Mold flash or protrusions shall not exceed .010 inch (0.25mm).
3. Terminal numbers are shown for reference only.
4. "C" dimension does not include solder finish thickness.
5. Symbol "N" is the maximum number of terminals.

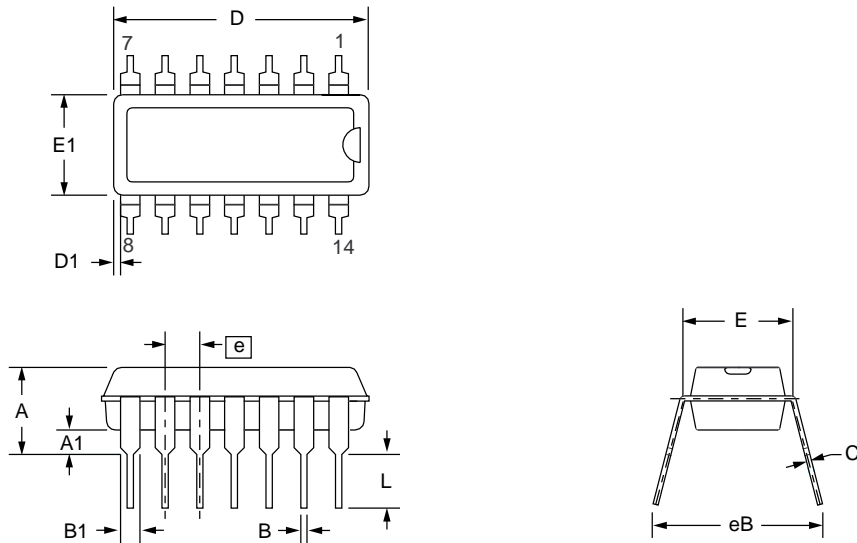



## Mechanical Dimensions (continued)

### 14-Lead SOIC Package

Symbol	Inches		Millimeters		Notes
	Min.	Max.	Min.	Max.	
A	.053	.069	1.35	1.75	
A1	.004	.010	0.10	0.25	
B	.013	.020	0.33	0.51	
C	.008	.010	0.19	0.25	5
D	.336	.345	8.54	8.76	2
E	.150	.158	3.81	4.01	2
e	.050 BSC		1.27 BSC		
H	.228	.244	5.79	6.20	
h	.010	.020	0.25	0.50	
L	.016	.050	0.40	1.27	3
N	14		14		6
$\alpha$	0°	8°	0°	8°	
ccc	—	.004	—	0.10	

#### Notes:

1. Dimensioning and tolerancing per ANSI Y14.5M-1982.
2. "D" and "E" do not include mold flash. Mold flash or protrusions shall not exceed .010 inch (0.25mm).
3. "L" is the length of terminal for soldering to a substrate.
4. Terminal numbers are shown for reference only.
5. "C" dimension does not include solder finish thickness.
6. Symbol "N" is the maximum number of terminals.

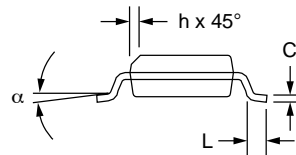
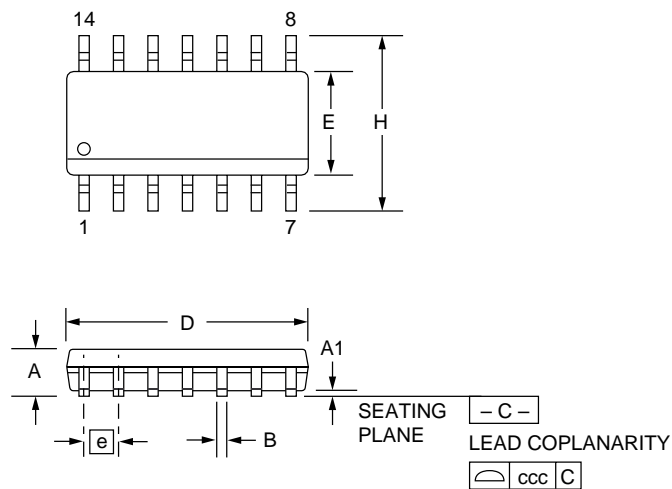

## Ordering Information

Product Number	Temperature Range	Screening	Package	Package Marking
RC4136N	0° to 70°C	Commercial	14 Pin Plastic DIP	RC4136N
RC4136M	0° to 70°C	Commercial	14 Pin Narrow SOIC	RC4136M
RM4136D	-55°C to +125°C		14 Pin Ceramic DIP	
RM4136D/883 <sup>1</sup>	-55°C to +125°C	Military	14 Pin Ceramic DIP	

**Note:**

1. /883 denotes MIL-STD-883, Par. 1.2.1 compliant device.

### LIFE SUPPORT POLICY

FAIRCHILD'S PRODUCTS ARE NOT AUTHORIZED FOR USE AS CRITICAL COMPONENTS IN LIFE SUPPORT DEVICES OR SYSTEMS WITHOUT THE EXPRESS WRITTEN APPROVAL OF THE PRESIDENT OF FAIRCHILD SEMICONDUCTOR CORPORATION. As used herein:

1. Life support devices or systems are devices or systems which, (a) are intended for surgical implant into the body, or (b) support or sustain life, and (c) whose failure to perform when properly used in accordance with instructions for use provided in the labeling, can be reasonably expected to result in a significant injury of the user.
2. A critical component in any component of a life support device or system whose failure to perform can be reasonably expected to cause the failure of the life support device or system, or to affect its safety or effectiveness.