

OLED DISPLAY SPECIFICATION



RAYSTAR

RAYSTAR Optronics, Inc.
曜凌光電股份有限公司



曜凌光電股份有限公司
Raystar Optronics, Inc.

T: +886-4-2565-0761 | F: +886-4-2565-0760
sales@raystar-optronics.com | www.raystar-optronics.com

SPECIFICATION

Model No:

REP012864Q-CTP

General Specification

The Features is described as follow:

- Module dimension: 82.0 × 47.5 × 8.65 Max.
- Active area: 61.41 × 30.69 mm
- Dot Matrix: 128 x 64
- Pixel size: 0.45 x 0.0.45 mm
- Pixel pitch: 0.48 x 0.48 mm
- Display Mode: Passive Matrix
- Duty: 1/64 Duty
- Display Color: Monochrome
- OLED IC: SSD1309
- OLED Interface: 6800,8080,4-Wire SPI,I2C
- SIZE:2.7 inch

- CTP IC:GT911
- Detect Point:1
- CTP Interface:I2C
- Surface: Normal Glare

Interface Pin Function

No.	Symbol	Function
1	VSS	Ground.
2	VDD	Power supply pin for core logic operation
3	NC	No connection
4	D/C#	This pin is Data/Command control pin connecting to the MCU. When the pin is pulled HIGH, the data at D[7:0] will be interpreted as data. When the pin is pulled LOW, the data at D[7:0] will be transferred to a command register. In I2C mode, this pin acts as SA0 for slave address selection.
5	R/W# (WR#)	This pin is read / write control input pin connecting to the MCU interface. When 6800 interface mode is selected, this pin will be used as Read/Write (R/W#) selection input. Read mode will be carried out when this pin is pulled HIGH and write mode when LOW. When 8080 interface mode is selected, this pin will be the Write (WR#) input. Data write operation is initiated when this pin is pulled LOW and the chip is selected. When serial or I2C interface is selected, this pin must be connected to VSS.
6	E(/RD#)	This pin is MCU interface input. When 6800 interface mode is selected, this pin will be used as the Enable (E) signal. Read/write operation is initiated when this pin is pulled HIGH and the chip is selected. When 8080 interface mode is selected, this pin receives the Read (RD#) signal. Read operation is initiated when this pin is pulled LOW and the chip is selected. When serial or I2C interface is selected, this pin must be connected to VSS.
7-14	D0~D7	These pins are bi-directional data bus connecting to the MCU data bus. Unused pins are recommended to tie LOW. When serial interface mode is selected, D0 will be the serial clock input: SCLK; D1 will be the serial data input: SDIN and D2 should be kept NC. When I2C mode is selected, D2, D1 should be tied together and serve as SDAout, SDAin in application and D0 is the serial clock input, SCL.
15	NC	No connection
16	RES#	This pin is reset signal input. When the pin is pulled LOW, initialization of the chip is executed. Keep this pin pull HIGH during normal operation.
17	CS#	This pin is the chip select input connecting to the MCU. The chip is enabled for MCU communication only when CS# is pulled LOW (active LOW).
18	NC	No connection

19	BS2	MCU bus interface selection pins. Select appropriate logic setting as described in the following table. BS2 and BS1 are pin select															
20	BS1	<table border="1"> <thead> <tr> <th></th> <th>BS1</th> <th>BS2</th> </tr> </thead> <tbody> <tr> <td>I2C</td> <td>1</td> <td>0</td> </tr> <tr> <td>4-wire Serial</td> <td>0</td> <td>0</td> </tr> <tr> <td>8-bit 68XX Parallel</td> <td>0</td> <td>1</td> </tr> <tr> <td>8-bit 80XX Parallel</td> <td>1</td> <td>1</td> </tr> </tbody> </table>		BS1	BS2	I2C	1	0	4-wire Serial	0	0	8-bit 68XX Parallel	0	1	8-bit 80XX Parallel	1	1
			BS1	BS2													
		I2C	1	0													
		4-wire Serial	0	0													
		8-bit 68XX Parallel	0	1													
8-bit 80XX Parallel	1	1															
Note																	
(1) 0 is connected to VSS																	
(2) 1 is connected to VDD																	
21	TP_SCK	I2C clock signal															
22	TP_SDA	I2C data signal															
23	TP_INT	External interrupt signal, active low															
24	TP_RST	External reset signal, active low															

RAYSTAR OPTRONICS

Contour Drawing & Block Diagram

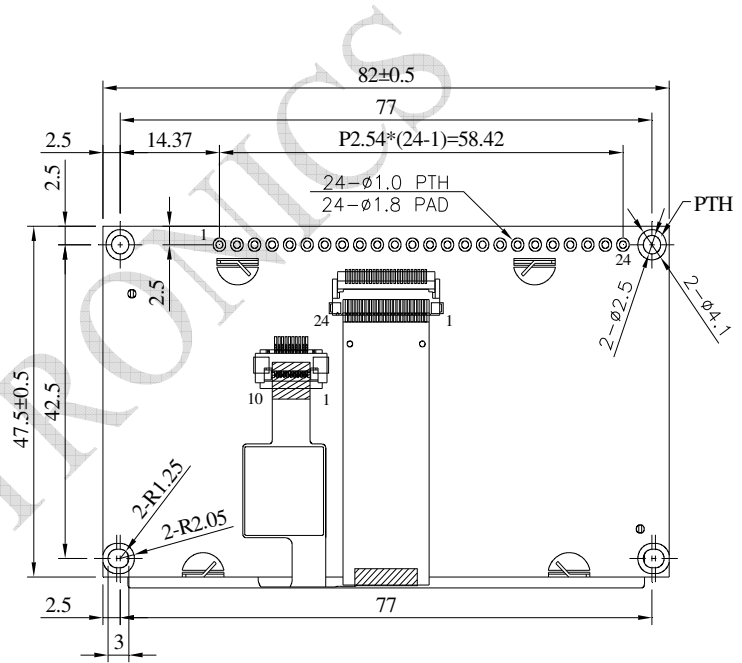
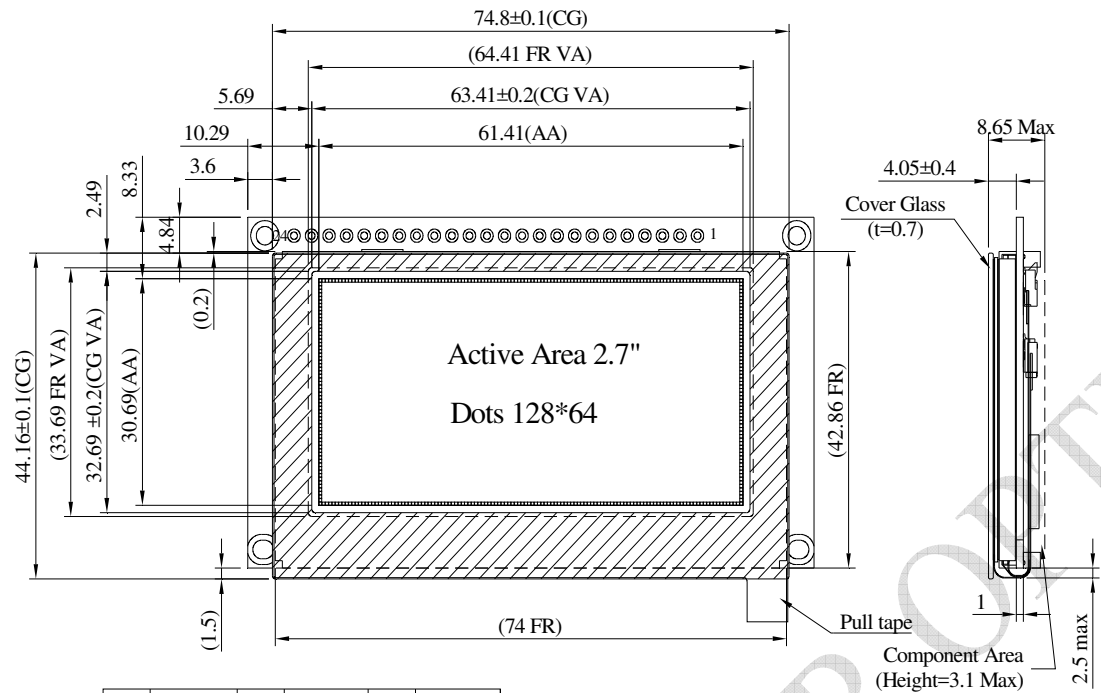

PIN	SYMBOL	PIN	SYMBOL	PIN	SYMBOL
1	VSS	9	DB2	17	CS#
2	VDD	10	DB3	18	NC
3	NC	11	DB4	19	BS2
4	D/C#	12	DB5	20	BS1
5	R/W#(WR#)	13	DB6	21	TP_SCK
6	E(/RD#)	14	DB7	22	TP_SDA
7	DB0	15	NC	23	TP_INT
8	DB1	16	RES#	24	TP_RST

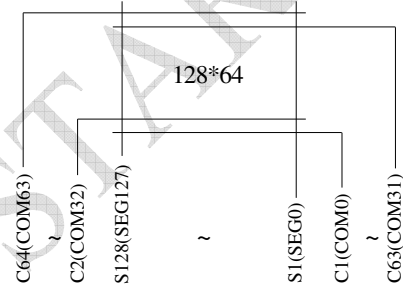

SEG & COM Layout

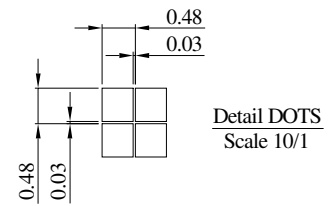

The non-specified tolerance of dimension is ± 0.3 mm .

Absolute Maximum Ratings

Parameter	Symbol	Min	Max	Unit
Supply Voltage for Logic	VDD	-0.3	4	V
Operating Temperature	TOP	-20	+70	°C
Storage Temperature	TSTG	-30	+80	°C

Electrical Characteristics

1. DC Electrical Characteristics

Item	Symbol	Condition	Min	Typ	Max	Unit
Supply Voltage for Logic	VDD	—	2.8	3.0	3.3	V
High Level Input	VIH	—	0.8×VDD	—	—	V
Low Level Input	VIL	—	—	—	0.2×VDD	V
High Level Output	VOH	—	0.9×VDD	—	—	V
Low Level Output	VOL	—	—	—	0.1×VDD	V
50% Check Board operating Current		VDD =3V	—	175	350	mA

2 Touch Panel Controller GT911

Item	Symbol	Min	Typ	Max	Unit
Input High Volt.	VIH	0.75×VDD		VDD+0.3	V
Input Low Volt.	VIL	-0.3	—	0.25×VDD	V
Output High Volt.	VOH	0.85×VDD	—	—	V
Output Low Volt.	VOL	—	—	0.15×VDD	V