

# RJP30E2DPP-M0

## Silicon N Channel IGBT High Speed Power Switching

### Features

- Trench gate technology (G5H series)
- Low collector to emitter saturation voltage  $V_{CE(sat)} = 1.7 \text{ V typ}$
- High speed switching  $t_f = 150 \text{ ns typ}$
- Low leak current  $I_{CES} = 1 \mu\text{A max}$
- Isolated package TO-220FL

### Outline

RENESAS Package code: PRSS0003AF-A)  
(Package name: TO-220FL)

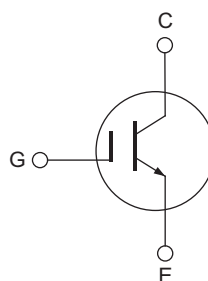
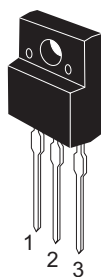

1. Gate
2. Collector
3. Emitter

### Absolute Maximum Ratings

( $T_a = 25^\circ\text{C}$ )

Item	Symbol	Ratings	Unit
Collector to emitter voltage	$V_{CES}$	360	V
Gate to emitter voltage	$V_{GES}$	$\pm 30$	V
Collector current	$I_C$	35	A
Collector peak current	$i_{c(peak)}$ <sup>Note1</sup>	200	A
Collector dissipation	$P_C$ <sup>Note2</sup>	25	W
Junction to case thermal impedance	$\theta_{j-c}$	5	$^\circ\text{C}/\text{W}$
Junction temperature	$T_j$	150	$^\circ\text{C}$
Storage temperature	$T_{stg}$	-55 to +150	$^\circ\text{C}$

Notes: 1.  $PW \leq 10 \mu\text{s}$ , duty cycle  $\leq 1\%$

2.  $T_c = 25^\circ\text{C}$

## Electrical Characteristics

(Ta = 25°C)

Item	Symbol	Min	Typ	Max	Unit	Test Conditions
Zero gate voltage collector current	$I_{CES}$	—	—	1	$\mu\text{A}$	$V_{CE} = 360 \text{ V}, V_{GE} = 0$
Gate to emitter leak current	$I_{GES}$	—	—	$\pm 100$	nA	$V_{GE} = \pm 30 \text{ V}, V_{CE} = 0$
Gate to emitter cutoff voltage	$V_{GE(off)}$	2.5	—	5	V	$V_{CE} = 10 \text{ V}, I_C = 1 \text{ mA}$
Collector to emitter saturation voltage	$V_{CE(sat)}$	—	1.7	2.2	V	$I_C = 35 \text{ A}, V_{GE} = 15 \text{ V}$ <sup>Note3</sup>
Input capacitance	$C_{ies}$	—	1160	—	pF	$V_{CE} = 25 \text{ V}$
Output capacitance	$C_{oes}$	—	60	—	pF	$V_{GE} = 0$
Reveres transfer capacitance	$C_{res}$	—	26	—	pF	$f = 1 \text{ MHz}$
Total gate charge	$Q_g$	—	34	—	nC	$V_{GE} = 15 \text{ V}$
Gate to emitter charge	$Q_{ge}$	—	6	—	nC	$V_{CE} = 150 \text{ V}$
Gate to collector charge	$Q_{gc}$	—	10	—	nC	$I_C = 35 \text{ A}$
Switching time	$t_{d(on)}$	—	0.03	—	$\mu\text{s}$	$I_C = 35 \text{ A}$
	$t_r$	—	0.1	—	$\mu\text{s}$	$R_L = 4.5 \Omega$
	$t_{d(off)}$	—	0.08	—	$\mu\text{s}$	$V_{GE} = 15 \text{ V}$
	$t_f$	—	0.15	—	$\mu\text{s}$	$R_G = 5 \Omega$

Notes: 3. Pulse test.

### Main Characteristics

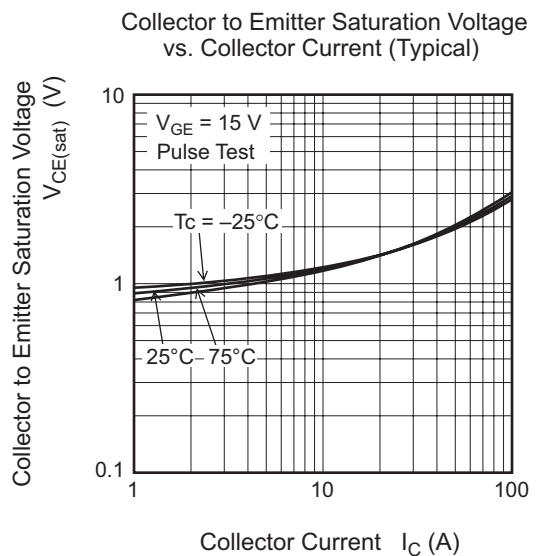
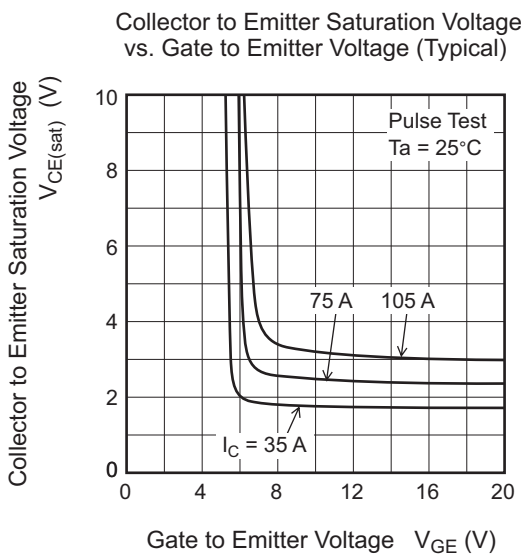
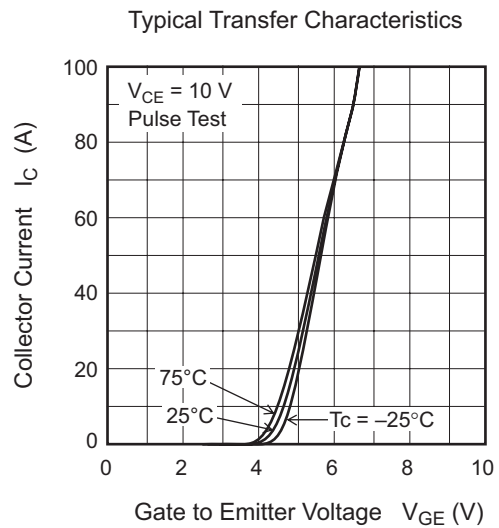
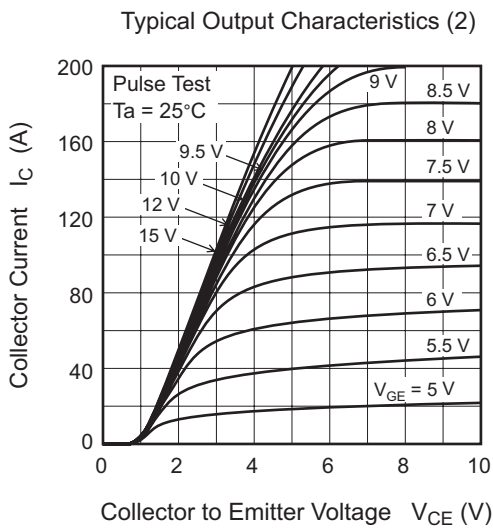
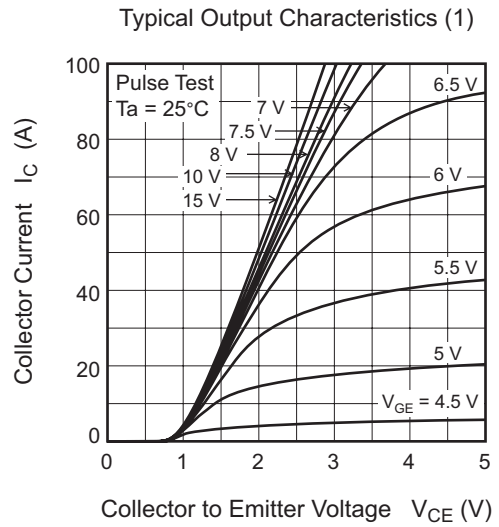
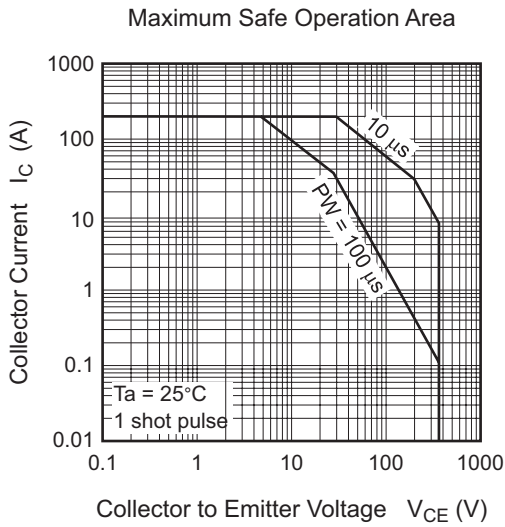

Typical Capacitance vs. Collector to Emitter Voltage

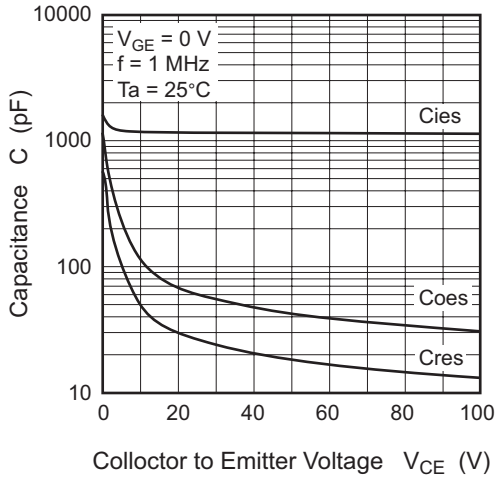

Dynamic Input Characteristics (Typical)

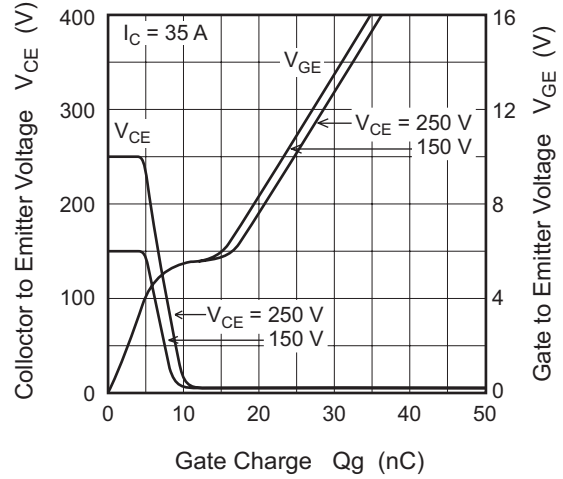

Switching Characteristics (Typical) (1)

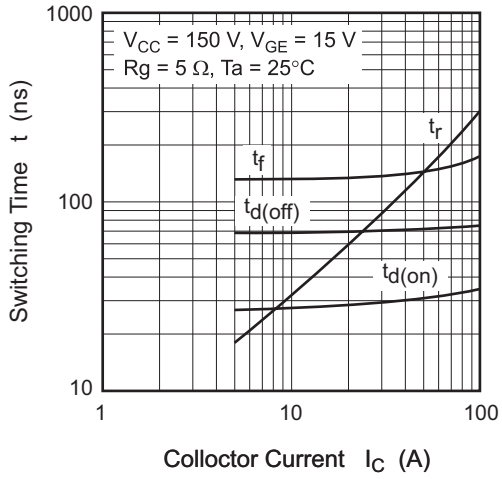

Switching Characteristics (Typical) (2)

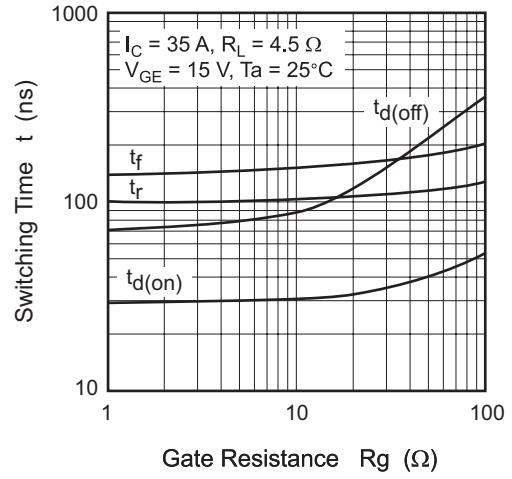

Switching Characteristics (Typical) (3)

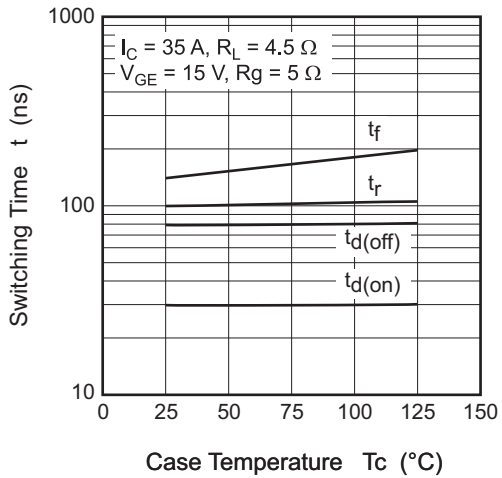

Normalized Transient Thermal Impedance vs. Pulse Width

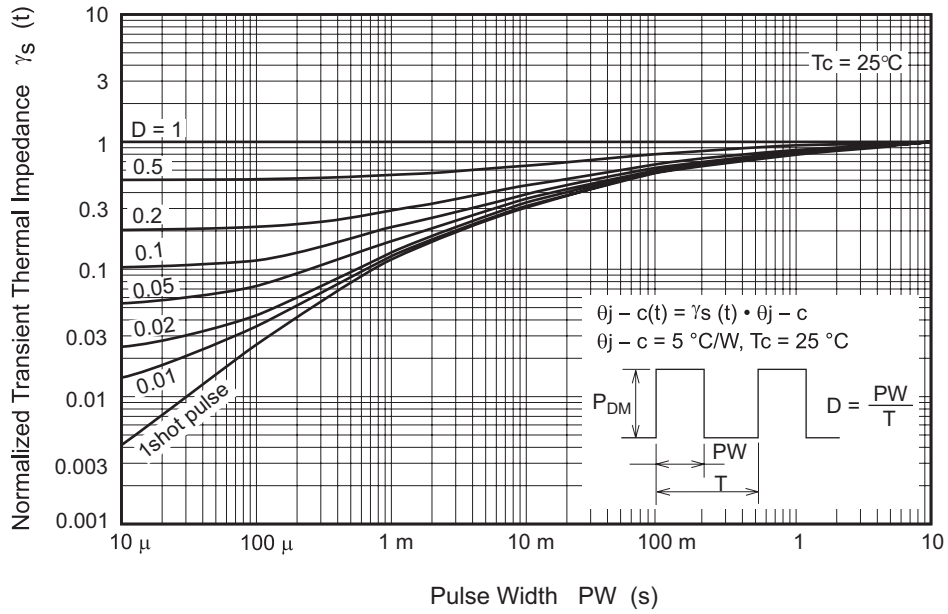

Switching Time Test Circuit

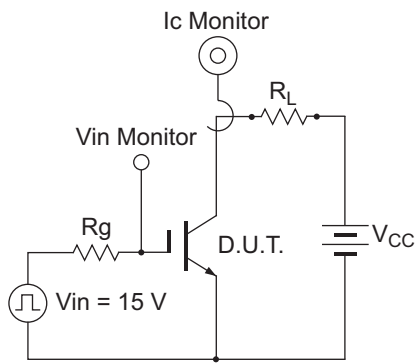

Waveform

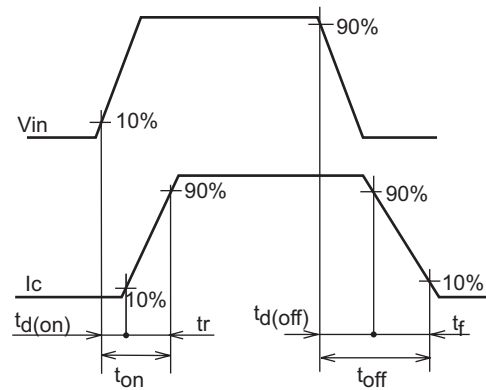

## Package Dimension

Package Name	JEITA Package Code	RENESAS Code	Previous Code	MASS[Typ.]
TO-220FL	—	PRSS0003AF-A	TO-220FL	1.5g

Unit: mm

