

SN5440, SN54LS40, SN54S40 SN7440, SN74LS40, SN74S40 DUAL 4-INPUT POSITIVE-NAND BUFFERS

SDLS108 – APRIL 1985 – REVISED MARCH 1988

- Package Options Include Plastic "Small Outline" Packages, Ceramic Chip Carriers and Flat Packages in Addition to Plastic and Ceramic DIPs
- Dependable Texas Instruments Quality and Reliability

description

These devices contain two independent 4-input NAND buffer gates.

The SN5440, SN54LS40, and SN54S40 are characterized for operation over the full military temperature range of -55°C to 125°C. The SN7440, SN74LS40, and SN74S40 are characterized for operation from 0°C to 70°C.

FUNCTION TABLE (each gate)

INPUTS				OUTPUT
A	B	C	D	Y
H	H	H	H	L
L	X	X	X	H
X	L	X	X	H
X	X	L	X	H
X	X	X	L	H

logic symbol†

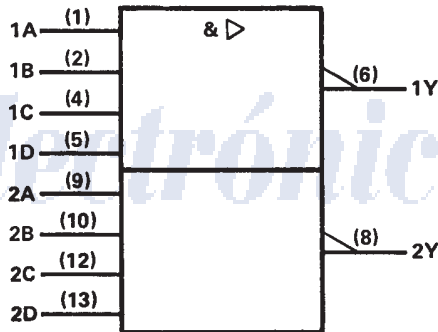

†This symbol is in accordance with ANSI/IEEE Std. 91-1984 and IEC Publication 617-12.

Pin numbers shown are for D, J, N, and W packages.

SN5440 . . . J PACKAGE
SN54LS40, SN54S40 . . . J OR W PACKAGE
SN7440 . . . N PACKAGE
SN74LS40, SN74S40 . . . D OR N PACKAGE
(TOP VIEW)

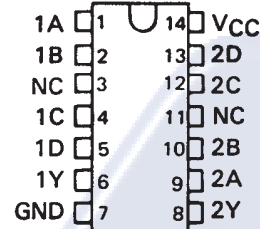

SN5440 . . . W PACKAGE
(TOP VIEW)

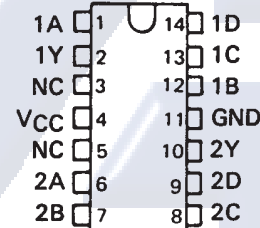

SN54LS40, SN54S40 . . . FK PACKAGE
(TOP VIEW)

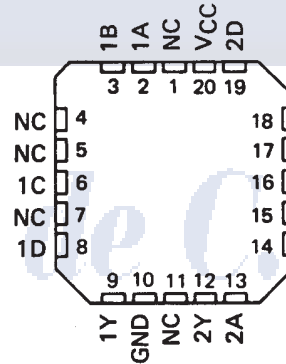

NC - No internal connection

logic diagram

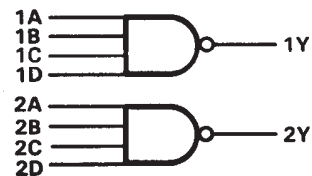

positive logic

$$Y = A \cdot B \cdot C \cdot D \text{ or } Y = \bar{A} + \bar{B} + \bar{C} + \bar{D}$$

**SN5440, SN54LS40, SN54S40
SN7440, SN74LS40, SN74S40
DUAL 4-INPUT POSITIVE-NAND BUFFERS**

SDLS108 – APRIL 1985 – REVISED MARCH 1988

schematics (each gate)

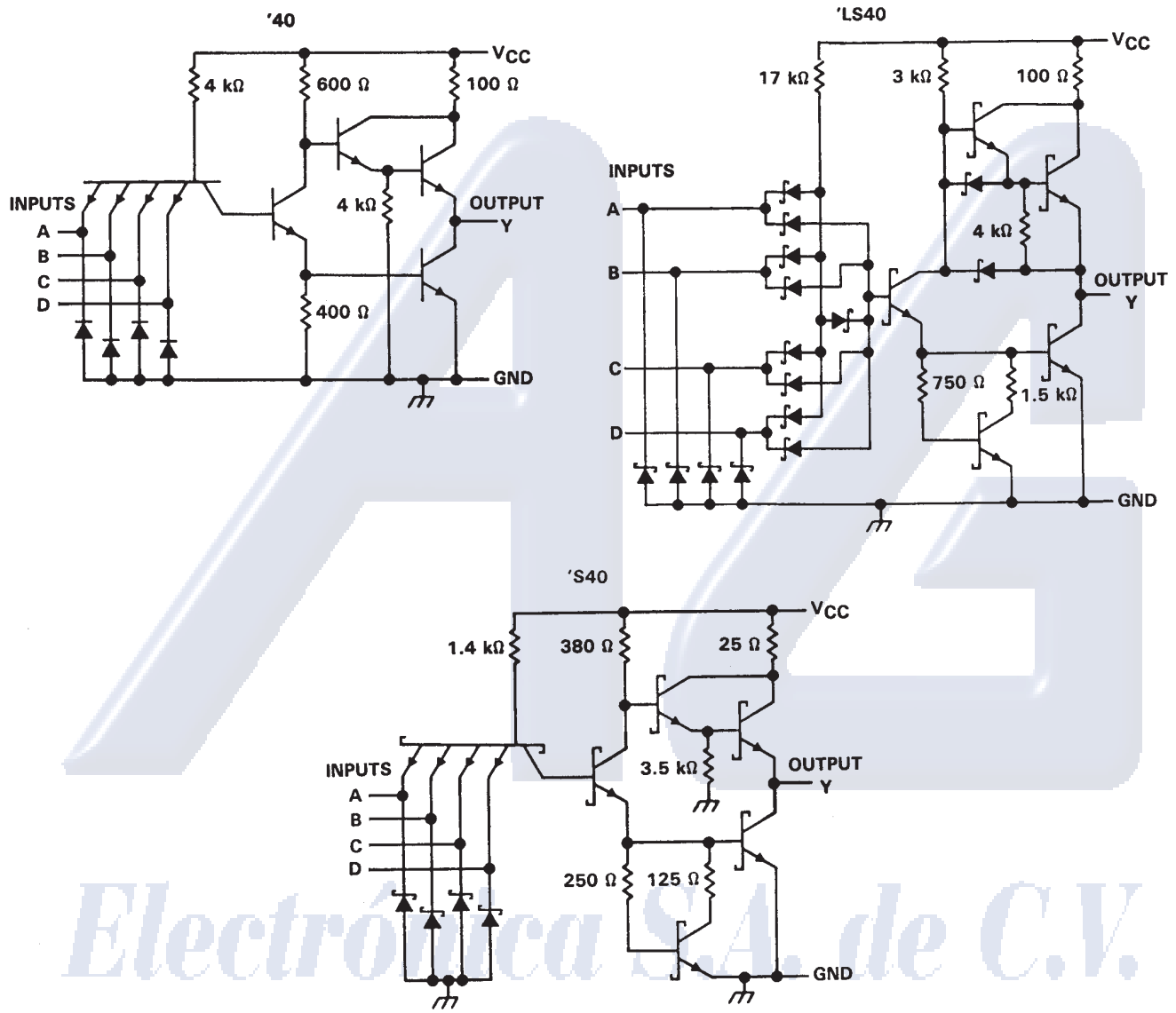

Resistor values shown are nominal.

absolute maximum ratings over operating free-air temperature range (unless otherwise noted)

Supply voltage, V _{CC} (see Note 1)	7 V
Input voltage: '40, 'S40	5.5 V
'LS40	7 V
Operating free-air temperature range: SN54'	-55°C to 125°C
SN74'	0°C to 70°C
Storage temperature range	-65°C to 150°C

NOTE 1: Voltage values are with respect to network ground terminal.



POST OFFICE BOX 655303 • DALLAS, TEXAS 75265

SN5440, SN54LS40, SN54S40
SN7440, SN74LS40, SN74S40
DUAL 4-INPUT POSITIVE-NAND BUFFERS

SDLS108 – APRIL 1985 – REVISED MARCH 1988

recommended operating conditions

	SN5440			SN7440			UNIT
	MIN	NOM	MAX	MIN	NOM	MAX	
V _{CC} Supply voltage	4.5	5	5.5	4.75	5	5.25	V
V _{IH} High-level input voltage	2			2			V
V _{IL} Low-level input voltage				0.8			V
I _{OH} High-level output current	-1.2			-1.2			mA
I _{OL} Low-level output current	48			48			mA
T _A Operating free-air temperature	-55		125	0		70	°C

electrical characteristics over recommended operating free-air temperature range (unless otherwise noted)

PARAMETER	TEST CONDITIONS †	SN5440			SN7440			UNIT
		MIN	TYP ‡	MAX	MIN	TYP ‡	MAX	
V _{IK}	V _{CC} = MIN, I _I = -12 mA	-1.5			-1.5			V
V _{OH}	V _{CC} = MIN, V _{IL} = 0.8 V, I _{OH} = -1.2 mA	2.4	3.3		2.4	3.3	V	
V _{OL}	V _{CC} = MIN, V _{IH} = 2 V, I _{OL} = 48 mA	0.2 0.4		0.2 0.4			V	
I _I	V _{CC} = MAX, V _I = 5.5 V	1			1			mA
I _{IH}	V _{CC} = MAX, V _I = 2.4 V	40			40			μA
I _{IL}	V _{CC} = MAX, V _I = 0.4 V	-1.6			-1.6			mA
I _{OS} §	V _{CC} = MAX	-20 -70		-18 -70			mA	
I _{CCH}	V _{CC} = MAX, V _I = 0	4 8		4 8			mA	
I _{CCL}	V _{CC} = MAX, V _I = 4.5 V	17 27		17 27			mA	

† For conditions shown as MIN or MAX, use the appropriate value specified under recommended operating conditions.

‡ All typical values are at V_{CC} = 5 V, T_A = 25°C.

§ Not more than one output should be shorted at a time, and the duration of the short circuit should not exceed 100 milliseconds.

switching characteristics, V_{CC} = 5 V, T_A = 25°C (see note 2)

PARAMETER	FROM (INPUT)	TO (OUTPUT)	TEST CONDITIONS		MIN	TYP	MAX	UNIT
t _{PLH}	Any	Y	R _L = 133 Ω,	C _L = 15 pF		13	22	ns
t _{PHL}						8	15	ns

NOTE 2: Load circuits and voltage waveforms are shown in Section 1.

Electrónica S.A. de C.V.



SN5440, SN54LS40, SN54S40 SN7440, SN74LS40, SN74S40 DUAL 4-INPUT POSITIVE-NAND BUFFERS

SDLS108 – APRIL 1985 – REVISED MARCH 1988

recommended operating conditions

	SN54LS40			SN74LS40			UNIT
	MIN	NOM	MAX	MIN	NOM	MAX	
V_{CC} Supply voltage	4.5	5	5.5	4.75	5	5.25	V
V_{IH} High-level input voltage	2			2			V
V_{IL} Low-level input voltage	0.7			0.8			V
I_{OH} High-level output current	-1.2			-1.2			mA
I_{OL} Low-level output current	12			24			mA
T_A Operating free-air temperature	-55			125			°C

electrical characteristics over recommended operating free-air temperature range (unless otherwise noted)

PARAMETER	TEST CONDITIONS †	SN54LS40			SN74LS40			UNIT
		MIN	TYP ‡	MAX	MIN	TYP ‡	MAX	
V_{IK}	$V_{CC} = \text{MIN}$, $I_I = -18 \text{ mA}$	-1.5			-1.5			V
V_{OH}	$V_{CC} = \text{MIN}$, $V_{IL} = \text{MAX}$, $I_{OH} = -1.2 \text{ mA}$	2.5	3.4		2.7	3.4		V
V_{OL}	$V_{CC} = \text{MIN}$, $V_{IH} = 2 \text{ V}$, $I_{OL} = 12 \text{ mA}$	0.25			0.25			V
	$V_{CC} = \text{MIN}$, $V_{IH} = 2 \text{ V}$, $I_{OL} = 24 \text{ mA}$				0.35			
I_I	$V_{CC} = \text{MAX}$, $V_I = 7 \text{ V}$	0.1			0.1			mA
I_{IH}	$V_{CC} = \text{MAX}$, $V_I = 2.7 \text{ V}$	20			20			μA
I_{IL}	$V_{CC} = \text{MAX}$, $V_I = 0.4 \text{ V}$	-0.4			-0.4			mA
$I_{OS} §$	$V_{CC} = \text{MAX}$	-30		-130	-30		-130	mA
I_{CCH}	$V_{CC} = \text{MAX}$, $V_I = 0$	0.45			0.45			mA
I_{CCL}	$V_{CC} = \text{MAX}$, $V_I = 4.5 \text{ V}$	3			3			mA

† For conditions shown as MIN or MAX, use the appropriate value specified under recommended operating conditions.

‡ All typical values are at $V_{CC} = 5 \text{ V}$, $T_A = 25^\circ\text{C}$.

§ Not more than one output should be shorted at a time, and the duration of the short circuit should not exceed one second.

switching characteristics, $V_{CC} = 5 \text{ V}$, $T_A = 25^\circ\text{C}$ (see note 2)

PARAMETER	FROM (INPUT)	TO (OUTPUT)	TEST CONDITIONS	MIN	TYP	MAX	UNIT
t_{PLH}	Any	Y	$R_L = 667 \Omega$, $C_L = 45 \text{ pF}$	12		24	ns
t_{PHL}				12		24	ns

NOTE 2: Load circuits and voltage waveforms are shown in Section 1.

Electrónica S.A. de C.V.



POST OFFICE BOX 655303 • DALLAS, TEXAS 75265

SN5440, SN54LS40, SN54S40
SN7440, SN74LS40, SN74S40
DUAL 4-INPUT POSITIVE-NAND BUFFERS

SDLS108 – APRIL 1985 – REVISED MARCH 1988

recommended operating conditions

	SN54S40			SN74S40			UNIT
	MIN	NOM	MAX	MIN	NOM	MAX	
V_{CC} Supply voltage	4.5	5	5.5	4.75	5	5.25	V
V_{IH} High-level input voltage	2			2			V
V_{IL} Low-level input voltage	0.8			0.8			V
I_{OH} High-level output current	– 3			– 3			mA
I_{OL} Low-level output current	60			60			mA
T_A Operating free-air temperature	– 55			125			°C

electrical characteristics over recommended operating free-air temperature range (unless otherwise noted)

PARAMETER	TEST CONDITIONS †	SN54S40			SN74S40			UNIT	
		MIN	TYP ‡	MAX	MIN	TYP ‡	MAX		
V_{IK}	$V_{CC} = \text{MIN}$, $I_I = -18 \text{ mA}$	– 1.2			– 1.2			V	
V_{OH}	$V_{CC} = \text{MIN}$, $V_{IL} = 0.8 \text{ V}$, $I_{OH} = -3 \text{ mA}$	2.5	3.4		2.7	3.4	V		
V_{OL}	$V_{CC} = \text{MIN}$, $V_{IH} = 2 \text{ V}$, $I_{OL} = 60 \text{ mA}$	0.5			0.5			V	
I_I	$V_{CC} = \text{MAX}$, $V_I = 5.5 \text{ V}$	1			1			mA	
I_{IH}	$V_{CC} = \text{MAX}$, $V_I = 2.7 \text{ V}$	0.1			0.1			mA	
I_{IL}	$V_{CC} = \text{MAX}$, $V_I = 0.5 \text{ V}$	– 4			– 4			mA	
$I_{OS} §$	$V_{CC} = \text{MAX}$	– 50		– 225	– 50		– 225	mA	
I_{CCH}	$V_{CC} = \text{MAX}$, $V_I = 0$	10			10			18	mA
I_{CCL}	$V_{CC} = \text{MAX}$, $V_I = 4.5 \text{ V}$	25			25			44	mA

† For conditions shown as MIN or MAX, use the appropriate value specified under recommended operating conditions.

‡ All typical values are at $V_{CC} = 5 \text{ V}$, $T_A = 25^\circ\text{C}$.

§ Not more than one output should be shorted at a time, and the duration of the short-circuit should not exceed 100 milliseconds.

switching characteristics, $V_{CC} = 5 \text{ V}$, $T_A = 25^\circ\text{C}$ (see note 2)

PARAMETER	FROM (INPUT)	TO (OUTPUT)	TEST CONDITIONS	MIN	TYP	MAX	UNIT
t_{PLH}	Any	Y	$R_L = 93 \Omega$, $C_L = 50 \text{ pF}$	4	6.5		ns
t_{PHL}				4	6.5		ns
t_{PLH}			$R_L = 93 \Omega$, $C_L = 150 \text{ pF}$	6			ns
t_{PHL}				6			ns

NOTE 2: Load circuits and voltage waveforms are shown in Section 1.

Electrónica S.A. de C.V.



IMPORTANT NOTICE

Texas Instruments and its subsidiaries (TI) reserve the right to make changes to their products or to discontinue any product or service without notice, and advise customers to obtain the latest version of relevant information to verify, before placing orders, that information being relied on is current and complete. All products are sold subject to the terms and conditions of sale supplied at the time of order acknowledgement, including those pertaining to warranty, patent infringement, and limitation of liability.

TI warrants performance of its semiconductor products to the specifications applicable at the time of sale in accordance with TI's standard warranty. Testing and other quality control techniques are utilized to the extent TI deems necessary to support this warranty. Specific testing of all parameters of each device is not necessarily performed, except those mandated by government requirements.

CERTAIN APPLICATIONS USING SEMICONDUCTOR PRODUCTS MAY INVOLVE POTENTIAL RISKS OF DEATH, PERSONAL INJURY, OR SEVERE PROPERTY OR ENVIRONMENTAL DAMAGE ("CRITICAL APPLICATIONS"). TI SEMICONDUCTOR PRODUCTS ARE NOT DESIGNED, AUTHORIZED, OR WARRANTED TO BE SUITABLE FOR USE IN LIFE-SUPPORT DEVICES OR SYSTEMS OR OTHER CRITICAL APPLICATIONS. INCLUSION OF TI PRODUCTS IN SUCH APPLICATIONS IS UNDERSTOOD TO BE FULLY AT THE CUSTOMER'S RISK.

In order to minimize risks associated with the customer's applications, adequate design and operating safeguards must be provided by the customer to minimize inherent or procedural hazards.

TI assumes no liability for applications assistance or customer product design. TI does not warrant or represent that any license, either express or implied, is granted under any patent right, copyright, mask work right, or other intellectual property right of TI covering or relating to any combination, machine, or process in which such semiconductor products or services might be or are used. TI's publication of information regarding any third party's products or services does not constitute TI's approval, warranty or endorsement thereof.

Electrónica S.A. de C.V.

Copyright © 1999, Texas Instruments Incorporated