

# SN55116, SN75116, SN75117, SN75118, SN75119 DIFFERENTIAL LINE TRANSCEIVERS

SLLS073D – MAY 1976 – REVISED MAY 1998

## features common to all types

- Single 5-V Supply
- 3-State Driver Output Circuitry
- TTL-Compatible Driver Inputs
- TTL-Compatible Receiver Output
- Differential Line Operation
- Receiver Output Strobe (SN55116, SN75116, SN75117) or Enable (SN75118, SN75119)
- Designed for Party-Line (Data-Bus) Applications

## additional features of the SN55116/SN75116

- Choice of Ceramic or Plastic Packages
- Independent Driver and Receiver
- Choice of Open-Collector or Totem-Pole Outputs on Both Driver and Receiver
- Dual Data Inputs on Driver
- Optional Line-Termination Resistor in Receiver
- $\pm 15$ -V Receiver Common-Mode Capability
- Receiver Frequency-Response Control

## additional features of the SN75117

- Driver Output Internally Connected to Receiver Input

**The SN75118 is an SN75116 With 3-State Receiver Output Circuitry  
The SN75119 is an SN75117 With 3-State Receiver Output Circuitry**

## description

These integrated circuits are designed for use in interfacing between TTL-type digital systems and differential data-transmission lines. They are especially useful for party-line (data-bus) applications. Each of these circuit types combine in one package a 3-state differential line driver and a differential-input line receiver, both of which operate from a single 5-V power supply. The driver inputs and the receiver outputs are TTL compatible. The driver employed is similar to the SN55113 and SN75113 3-state line drivers, and the receiver is similar to the SN55115 and SN75115 line receivers.

The SN55116, SN75116, and SN75118 offer all the features of the SN55113 and SN75113 drivers and the SN55115 and SN75115 receivers combined. The driver performs the dual input AND and NAND functions when enabled or presents a high impedance to the load when in the disabled state. The driver output stages are similar to TTL totem-pole outputs, but have the current-sinking portion separated from the current-sourcing portion and both are brought out to adjacent package terminals. This feature allows the user the option of using the driver in the open-collector output configuration, or, by connecting the adjacent source and sink terminals together, of using the driver in the normal totem-pole output configuration.

The receiver portion of the SN55116, SN75116, and SN75118 features a differential-input circuit having a common-mode voltage range of  $\pm 15$  V. An internal 130- $\Omega$  equivalent resistor also is provided, which optionally can be used to terminate the transmission line. A frequency-response control terminal allows the user to reduce the speed of the receiver or to improve differential noise immunity. The receivers of the SN55116 and SN75116 have an output strobe and a split totem-pole output. The receiver of the SN75118 has an output-enable for the 3-state split totem-pole output. The receiver section of either circuit is independent of the driver section except for the  $V_{CC}$  and ground terminals.

The SN75117 and SN75119 provide the basic driver and receiver functions of the SN55116, SN75116, and SN75118, but use a package that is only half as large. The SN75117 and SN75119 are intended primarily for party-line or bus-organized systems because the driver outputs are internally connected to the receiver inputs. The driver has a single data input and a single enable input. The SN75117 receiver has an output strobe, while the SN75119 receiver has a 3-state output enable. However, these devices do not provide output connection options, line-termination resistors, or receiver frequency-response controls.



Please be aware that an important notice concerning availability, standard warranty, and use in critical applications of Texas Instruments semiconductor products and disclaimers thereto appears at the end of this data sheet.

PRODUCTION DATA information is current as of publication date. Products conform to specifications per the terms of Texas Instruments standard warranty. Production processing does not necessarily include testing of all parameters.

 **TEXAS  
INSTRUMENTS**

POST OFFICE BOX 655303 • DALLAS, TEXAS 75265

Copyright © 1998, Texas Instruments Incorporated

# SN55116, SN75116, SN75117, SN75118, SN75119 DIFFERENTIAL LINE TRANSCEIVERS

SLLS073D – MAY 1976 – REVISED MAY 1998

## description (continued)

The SN55116 is characterized for operation over the full military temperature range of  $-55^{\circ}\text{C}$  to  $125^{\circ}\text{C}$ . The SN75116, SN75117, SN75118, and SN75119 are characterized for operation from  $0^{\circ}\text{C}$  to  $70^{\circ}\text{C}$ .

**SN55116 . . . J PACKAGE**  
**SN75116 . . . D OR N PACKAGE**  
**(TOP VIEW)**

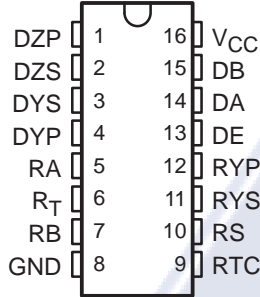

**SN75118 . . . D OR N PACKAGE**  
**(TOP VIEW)**

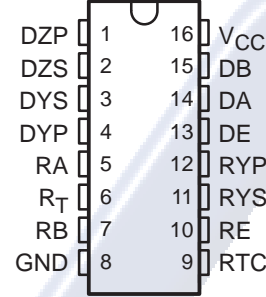

**SN55116 . . . FK PACKAGE**  
**(TOP VIEW)**

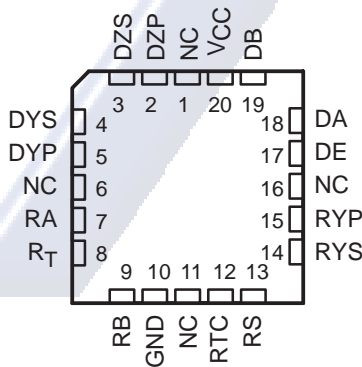

**SN75117 . . . D OR P PACKAGE**  
**(TOP VIEW)**

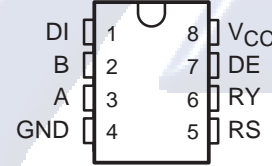

**SN75119 . . . D OR P PACKAGE**  
**(TOP VIEW)**

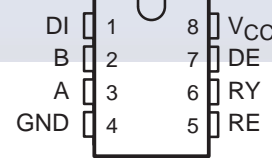

NC – No internal connection

## Function Tables

**'116, SN75118**  
**DRIVER**

INPUTS			OUTPUTS	
DE	DA	DB	DY	DZ
L	X	X	Z	Z
H	L	X	L	H
H	X	L	L	H
H	H	H	H	L

**'116, SN75118**  
**RECEIVER**

RS/RE	DIFF INPUT	OUTPUTS RY	
		'116	SN75118
L	X	H	Z
H	L	H	H
H	H	L	L

**SN75117, SN75119**  
**DRIVER**

INPUTS		OUTPUTS	
DI	DE	A	B
H	H	H	L
L	H	L	H
X	L	Z	Z

**SN75117, SN75119**  
**RECEIVER**

INPUTS			OUTPUT RY	
A	B	RS/RE	SN75117	SN75119
H	L	H	H	H
L	H	H	L	L
X	X	L	H	Z

H = high level ( $V_I \geq V_{IH}$  min or  $V_{ID}$  more positive than  $V_{TH}$  max), L = low level ( $V_I \leq V_{IL}$  max or  $V_{ID}$  more negative than  $V_{TL}$  max), X = irrelevant, Z = high impedance (off)

# SN55116, SN75116, SN75117, SN75118, SN75119 DIFFERENTIAL LINE TRANSCEIVERS

SLLS073D – MAY 1976 – REVISED MAY 1998

## logic symbol†

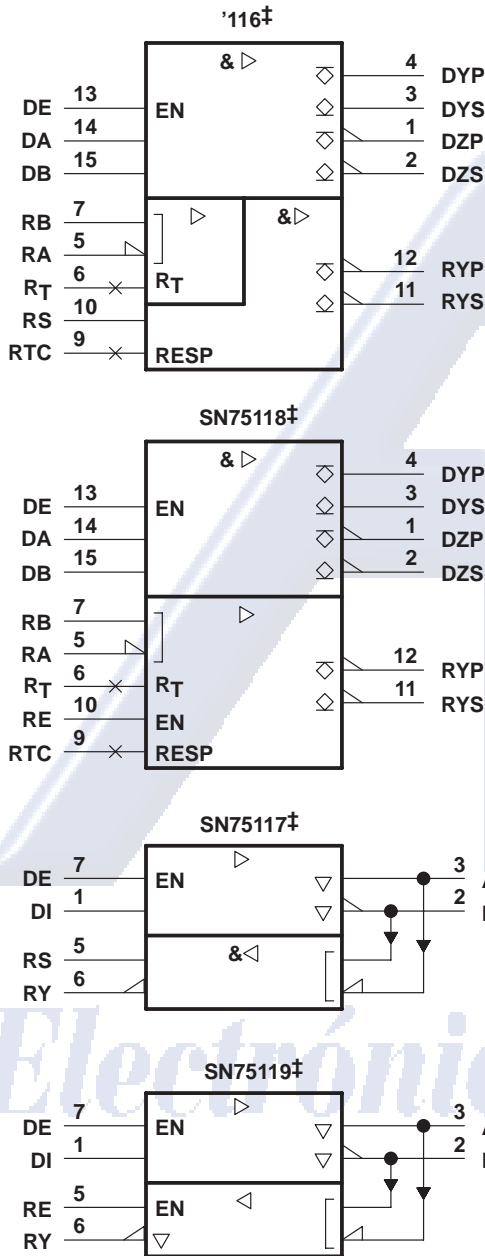

## logic diagram (positive logic)

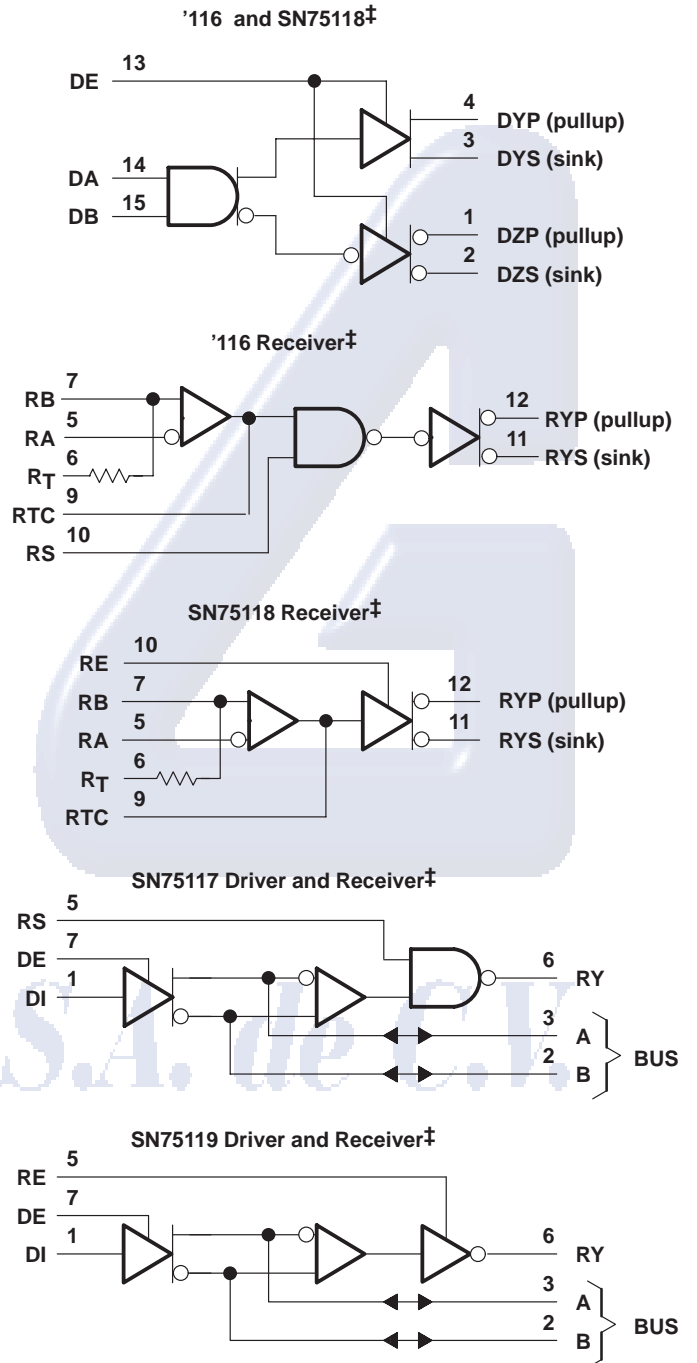

† These symbols are in accordance with ANSI/IEEE Std 91-1984 and IEC Publication 617-12.

‡ Pin numbers shown for the SN55116 and SN75116 are for the D, J, and N packages, those shown for the SN75118 are for the D and N packages, and those shown for SN75117 and SN75119 are for the D and P packages.

# SN55116, SN75116, SN75117, SN75118, SN75119 DIFFERENTIAL LINE TRANSCEIVERS

SLLS073D – MAY 1976 – REVISED MAY 1998

## schematics of inputs and outputs

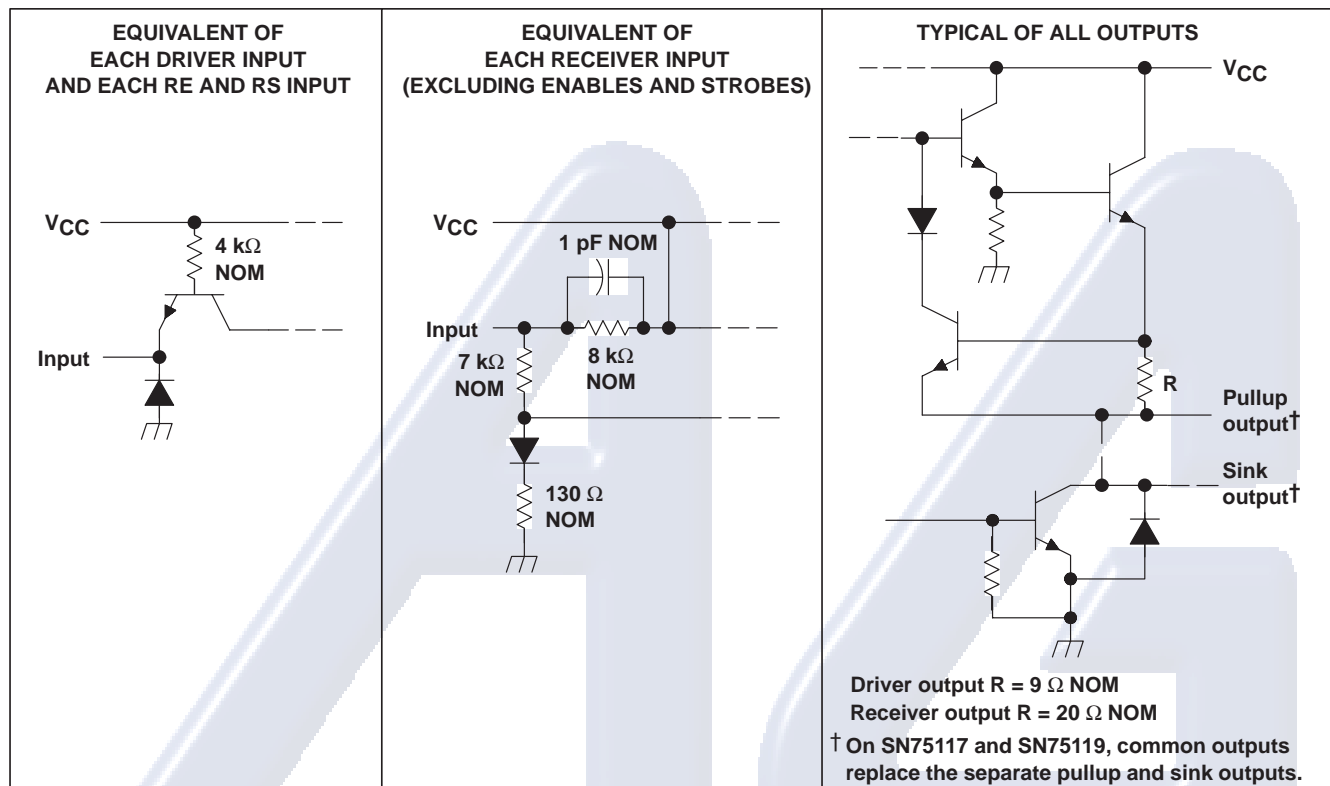

## absolute maximum ratings over operating free-air temperature (unless otherwise noted)‡

Supply voltage, $V_{CC}$ (see Notes 1 and 2)	7 V
Input voltage, $V_I$ : DA, DB, DE, DI, RE, and RS	5.5 V
RA, RB, $R_T$ for '116, SN75118 only	$\pm 25$ V
A and B for SN75117, SN75119 only	0 to 6 V
Off-state voltage applied to open-collector outputs: '116, SN75118 only	12 V
Continuous total power dissipation (see Note 2)	See Dissipation Rating Table
Storage temperature range, $T_{stg}$	$-65^\circ\text{C}$ to $150^\circ\text{C}$
Case temperature for 60 seconds, $T_C$ : FK package	$260^\circ\text{C}$
Lead temperature 1,6 mm (1/16 inch) from case for 60 seconds: J package	$300^\circ\text{C}$
Lead temperature 1,6 mm (1/16 inch) from case for 10 seconds: D, N, or P package	$260^\circ\text{C}$

‡ Stresses beyond those listed under "absolute maximum ratings" may cause permanent damage to the device. These are stress ratings only, and functional operation of the device at these or any other conditions beyond those indicated under "recommended operating conditions" is not implied. Exposure to absolute-maximum-rated conditions for extended periods may affect device reliability.

NOTES: 1. All voltage values are with respect to the network ground terminal.  
2. In the FK and J packages, the SN55116 chip is alloy mounted. The SN75116, SN75117, SN75118, and SN75119 chips are glass mounted.

# SN55116, SN75116, SN75117, SN75118, SN75119 DIFFERENTIAL LINE TRANSCEIVERS

SLLS073D – MAY 1976 – REVISED MAY 1998

DISSIPATION RATING TABLE

PACKAGE	$T_A \leq 25^\circ\text{C}$ POWER RATING	DERATING FACTOR ABOVE $T_A = 25^\circ\text{C}$	$T_A = 70^\circ\text{C}$ POWER RATING	$T_A = 125^\circ\text{C}$ POWER RATING
D (8 pin)	725 mW	5.8 mW/°C	464 mW	—
D (16 pin)	950 mW	7.6 mW/°C	608 mW	—
FK	1375 mW	11.0 mW/°C	880 mW	275 mW
J	1375 mW	11.0 mW/°C	880 mW	275 mW
N	1150 mW	9.2 mW/°C	736 mW	—
P	1000 mW	8.0 mW/°C	640 mW	—

## recommended operating conditions

PARAMETER	SN55116			SN75116, SN75117, SN75118, SN75119			UNIT
	MIN	NOM	MAX	MIN	NOM	MAX	
Supply voltage, $V_{CC}$	4.5	5	5.5	4.5	5	5.5	V
High-level input voltage, $V_{IH}$	All inputs except differential inputs			2			V
Low-level input voltage, $V_{IL}$						0.8	V
High-level output current, $I_{OH}$	Drivers					-40	mA
	Receivers					-5	
Low-level output current, $I_{OL}$	Drivers					40	mA
	Receivers					15	
Receiver input voltage, $V_I$	'116, SN75118					$\pm 15$	V
	SN75117, SN75119			0		6	
Common-mode receiver input voltage, $V_{ICR}$	'116, SN75118					$\pm 15$	V
	SN75117, SN75119			0		6	
Operating free-air temperature, $T_A$	-55			125			°C

# Electrónica S.A. de C.V.



**electrical characteristics over recommended operating free-air temperature range (unless otherwise noted)**

**driver section**

PARAMETER		TEST CONDITIONS†		'116, SN75118			SN75117, SN75119			UNIT
				MIN	TYP‡	MAX	MIN	TYP‡	MAX	
V <sub>IK</sub>	Input clamp voltage	V <sub>CC</sub> = MIN, I <sub>I</sub> = -12 mA		-0.9	-1.5		-0.9	-1.5	V	
V <sub>OH</sub>	High-level output voltage	V <sub>CC</sub> = MIN, V <sub>IL</sub> = 0.8 V, I <sub>IH</sub> = 2 V	T <sub>A</sub> = 25°C (SN55116), T <sub>A</sub> = 0°C to 70°C (SN75116, SN75117, SN75118, SN75119)	I <sub>OH</sub> = -10 mA	2.4	3.4	2.4	3.4	V	
				I <sub>OH</sub> = -40 mA	2	3	2	3		
			T <sub>A</sub> = -55°C to 125°C (SN55116)	I <sub>OH</sub> = -10 mA	2		2			
				I <sub>OH</sub> = -40 mA	1.8		1.8			
V <sub>OL</sub>	Low-level output voltage	V <sub>CC</sub> = MIN, V <sub>IH</sub> = 2 V, V <sub>IL</sub> = 0.8 V, I <sub>OL</sub> = 40 mA			0.4		0.4	V		
V <sub>OK</sub>	Output clamp voltage	V <sub>CC</sub> = MAX, I <sub>O</sub> = -40 mA, DE at 0.8 V			-1.5		-1.5	V		
I <sub>O(off)</sub>	Off-state open-collector output current	V <sub>CC</sub> = MAX, V <sub>O</sub> = 12 V	T <sub>A</sub> = 25°C	SN55116		1	10		µA	
			T <sub>A</sub> = MAX	SN75116, SN75118			200			
I <sub>OZ</sub>	Off-state (high-impedance-state) output current	V <sub>CC</sub> = MAX, DE at 0.8 V, T <sub>A</sub> = MAX	V <sub>O</sub> = 0 to V <sub>CC</sub> , DE at 0.8 V, T <sub>A</sub> = 25°C			±10			µA	
			V <sub>O</sub> = 0		SN55116		-300			
			V <sub>O</sub> = 0.4 V to V <sub>CC</sub>		SN55116		±150			
			V <sub>O</sub> = 0 to V <sub>CC</sub>		SN75116, SN75118		±20			
I <sub>I</sub>	Input current at maximum input voltage	Driver or enable input	V <sub>CC</sub> = MAX, V <sub>I</sub> = 5.5 V			1		1	mA	
I <sub>IH</sub>	High-level input current		V <sub>CC</sub> = MAX, V <sub>I</sub> = 2.4 V			40		40	µA	
I <sub>IL</sub>	Low-level input current		V <sub>CC</sub> = MAX, V <sub>I</sub> = 0.4 V			-1.6		-1.6	mA	
I <sub>OS</sub>	Short-circuit output current§	V <sub>CC</sub> = MAX, V <sub>O</sub> = 0, T <sub>A</sub> = 25°C		-40	-120	-40	-120	mA		
I <sub>CC</sub>	Supply current (driver and receiver combined)	V <sub>CC</sub> = MAX, T <sub>A</sub> = 25°C		42	60	42	60	mA		

† All parameters with the exception of off-state open-collector output current are measured with the active pullup connected to the sink output. For conditions shown as MIN or MAX, use the appropriate value specified under recommended operating conditions.

‡ All typical values are at V<sub>CC</sub> = 5 V and T<sub>A</sub> = 25°C.

§ Not more than one output should be shorted at a time, and duration of the short circuit should not exceed one second.

# SN55116, SN75116, SN75117, SN75118, SN75119 DIFFERENTIAL LINE TRANSCEIVERS

SLLS073D – MAY 1976 – REVISED MAY 1998

switching characteristics,  $V_{CC} = 5\text{ V}$ ,  $C_L = 30\text{ pF}$ ,  $T_A = 25^\circ\text{C}$

## driver section

PARAMETER		TEST CONDITIONS	MIN	TYP	MAX	UNIT
$t_{PLH}$	Propagation-delay time, low-to-high level output	See Figure 13		14	30	ns
$t_{PHL}$	Propagation-delay time, high-to-low level output			12	30	
$t_{PZH}$	Output-enable time to high level	$R_L = 180\ \Omega$ , See Figure 14		8	20	ns
$t_{PZL}$	Output-enable time to low level	$R_L = 250\ \Omega$ , See Figure 15		17	40	ns
$t_{PHZ}$	Output-disable time from high level	$R_L = 180\ \Omega$ , See Figure 14		16	30	ns
$t_{PLZ}$	Output-disable time from low level	$R_L = 250\ \Omega$ , See Figure 15		20	35	ns

# Electrónica S.A. de C.V.



POST OFFICE BOX 655303 • DALLAS, TEXAS 75265

electrical characteristics over recommended operating free-air temperature range (unless otherwise noted)

receiver section

PARAMETER	TEST CONDITIONS†		'116, SN75118			SN75117, SN75119			UNIT
			MIN	TYP‡	MAX	MIN	TYP‡	MAX	
V <sub>IT+</sub> Positive-going threshold voltage§	V <sub>O</sub> = 0.4 V, See Note 3	I <sub>OL</sub> = 15 mA,	V <sub>CC</sub> = MIN, V <sub>ICR</sub> = 0, See Note 4	0.5		0.5		V	
			V <sub>CC</sub> = 5 V, V <sub>ICR</sub> = MAX, See Note 5	1		1			
V <sub>IT-</sub> Negative-going threshold voltage§	V <sub>O</sub> = 2.4 V, See Note 3	I <sub>OL</sub> = -5 mA,	V <sub>CC</sub> = MIN, V <sub>ICR</sub> = 0, See Note 4	-0.5¶		-0.5¶		V	
			V <sub>CC</sub> = 5 V, V <sub>ICR</sub> = MAX, See Note 5	-1¶		-1¶			
V <sub>I</sub> Input voltage range#	V <sub>CC</sub> = 5 V,	V <sub>ID</sub> = -1 V or 1 V, See Note 3	15 to -15	6 to 0				V	
V <sub>OH</sub> High-level output voltage	I <sub>OH</sub> = -5 mA, See Note 3	V <sub>CC</sub> = MIN, V <sub>ICR</sub> = 0, V <sub>ID</sub> = -0.5 V, See Notes 4 and 6	2.4		2.4		V		
		V <sub>CC</sub> = 5 V, V <sub>ICR</sub> = MAX, V <sub>ID</sub> = -1 V, See Note 5	2.4		2.4				
V <sub>OL</sub> Low-level output voltage	I <sub>OL</sub> = 15 mA, See Note 3	V <sub>CC</sub> = MIN, V <sub>ICR</sub> = 0, V <sub>ID</sub> = 0.5 V, See Notes 4 and 7	0.4		0.4		V		
		V <sub>CC</sub> = 5 V, V <sub>ICR</sub> = MAX, V <sub>ID</sub> = 1 V, See Note 5	0.4		0.4				
I <sub>I(rec)</sub> Receiver input current	V <sub>CC</sub> = MAX, See Note 3	V <sub>I</sub> = 0, Other input at 0 V	-0.5	-0.9	-0.5	-1	mA		
		V <sub>I</sub> = 0.4 V, Other input at 2.4 V	-0.4	-0.7	-0.4	-0.8			
		V <sub>I</sub> = 2.4 V, Other input at 0.4 V	0.1	0.3	0.1	0.4			
I <sub>I</sub> Input current at maximum input voltage	Strobe	V <sub>CC</sub> = MIN, V <sub>ID</sub> = -0.5 V, V <sub>strobe</sub> = 4.5 V	5		5		µA		
	Enable	V <sub>CC</sub> = MAX, V <sub>I</sub> = 5.5 V	1		1		mA		

† Unless otherwise noted, V<sub>strobe</sub> = 2.4 V. All parameters, with the exception of off-state open-collector output current, are measured with the active pullup connected to the sink output. For conditions shown as MIN or MAX, use the appropriate value specified under recommended operating conditions.  
 ‡ All typical values are at V<sub>CC</sub> = 5 V, T<sub>A</sub> = 25°C, and V<sub>IC</sub> = 0.  
 § Differential voltages are at the B input terminal with respect to the A input terminal. Neither receiver input of the SN75117 or SN75119 should be taken negative with respect to GND.  
 ¶ The algebraic convention, where the less positive (more negative) limit is designated as minimum, is used in this data sheet for threshold voltages only.  
 # Input voltage range is the voltage range that, if exceeded at either input, will cause the receiver to cease functioning properly.  
 NOTES: 3. Measurement of these characteristics on the SN75117 and SN75119 requires the driver to be disabled with the driver enable at 0.8 V.  
 4. This applies with the less positive receiver input grounded.  
 5. For '116 and SN75118, this applies with the more positive receiver input at 15 V or the more negative receiver input at -15 V. For SN75117 and SN75119, this applies with the more positive receiver input at 6 V.  
 6. For SN55116, V<sub>ID</sub> = -1 V  
 7. For SN55116, V<sub>ID</sub> = 1 V





receiver section (continued)

PARAMETER			TEST CONDITIONS†			'116, SN75118			SN75117, SN75119			UNIT
						MIN	TYP‡	MAX	MIN	TYP‡	MAX	
I <sub>IH</sub>	High-level input current	Enable	V <sub>CC</sub> = MAX, V <sub>I</sub> = 2.4 V	SN75118, SN75119			40			40	μA	
I <sub>I</sub>	Low-level input current	Strobe	V <sub>CC</sub> = MAX, V <sub>ID</sub> = 0.5 V, V <sub>strobe</sub> = 0.4 V, See Notes 4 and 7	'116, SN75117			-2.4			-2.4	mA	
		Enable	V <sub>CC</sub> = MAX, V <sub>I</sub> = 0.4 V	SN75118, SN75119			-1.6			-1.6		
I <sub>(RTC)</sub>	Response-time-control current (RTC)		V <sub>CC</sub> = MAX, V <sub>ID</sub> = 0.5 V, RC at 0 V, See Notes 4 and 7	T <sub>A</sub> = 25°C			-1.2				mA	
I <sub>O(off)</sub>	Off-state open-collector output current		V <sub>CC</sub> = MAX, V <sub>O</sub> = 12 V, V <sub>ID</sub> = -1 V	T <sub>A</sub> = 25°C			1			10	μA	
				T <sub>A</sub> = MAX	SN55116			200				
I <sub>OZ</sub>	Off-state (high-impedance-state) output current		V <sub>CC</sub> = MAX, V <sub>O</sub> = 0 to V <sub>CC</sub> , RE at 0.4 V	T <sub>A</sub> = 25°C	SN75118, SN75119					±10	μA	
				T <sub>A</sub> = MAX	SN75118			±20				
					SN75119					±20		
R <sub>T</sub>	Line-terminating resistance		V <sub>CC</sub> = 5 V	T <sub>A</sub> = 25°C			77			167	Ω	
I <sub>OS</sub>	Short-circuit output current§		V <sub>CC</sub> = MAX, V <sub>ID</sub> = -0.5 V, V <sub>O</sub> = 0, See Notes 4 and 6	T <sub>A</sub> = 25°C			-15		-80	-15	-80	mA
I <sub>CC</sub>	Short current (driver and receiver combined)		V <sub>CC</sub> = MAX, V <sub>ID</sub> = 0.5 V, See Notes 4 and 7	T <sub>A</sub> = 25°C			42		60	42	60	mA

† Unless otherwise noted, V<sub>strobe</sub> = 2.4 V. All parameters, with the exception of off-state open-collector output current, are measured with the active pullup connected to the sink output.

For conditions shown as MIN or MAX, use the appropriate value specified under recommended operating conditions.

‡ All typical values are at V<sub>CC</sub> = 5 V, T<sub>A</sub> = 25°C, and V<sub>IC</sub> = 0.

§ Not more than one output should be shorted at a time.

NOTES: 4. This applies with the less positive receiver input grounded.

6. For SN55116, V<sub>ID</sub> = -1 V

7. For SN55116, V<sub>ID</sub> = 1 V

*Electrónica S.A. de C.V.*



# SN55116, SN75116, SN75117, SN75118, SN75119 DIFFERENTIAL LINE TRANSCEIVERS

SLLS073D – MAY 1976 – REVISED MAY 1998

switching characteristics,  $V_{CC} = 5\text{ V}$ ,  $C_L = 30\text{ pF}$ ,  $T_A = 25^\circ\text{C}$

## receiver section

PARAMETER		TEST CONDITIONS		MIN	TYP	MAX	UNIT
t <sub>PLH</sub>	Propagation-delay time, low-to-high-level output	R <sub>L</sub> = 400 Ω,    See Figure 16			20	75	ns
t <sub>PHL</sub>	Propagation-delay time, high-to-low-level output				17	75	ns
t <sub>PZH</sub>	Output-enable time to high level	SN75118 and SN75119 only	R <sub>L</sub> = 480 Ω,    See Figure 14		9	20	ns
t <sub>PZL</sub>	Output-enable time to low level		R <sub>L</sub> = 250 Ω,    See Figure 15		16	35	ns
t <sub>PHZ</sub>	Output-disable time from high level		R <sub>L</sub> = 480 Ω,    See Figure 14		12	30	ns
t <sub>PLZ</sub>	Output-disable time from low level		R <sub>L</sub> = 250 Ω,    See Figure 15		17	35	ns

# AGE

*Electrónica S.A. de C.V.*



POST OFFICE BOX 655303 • DALLAS, TEXAS 75265

# SN55116, SN75116, SN75117, SN75118, SN75119 DIFFERENTIAL LINE TRANSCEIVERS

SLLS073D – MAY 1976 – REVISED MAY 1998

## TYPICAL CHARACTERISTICS†

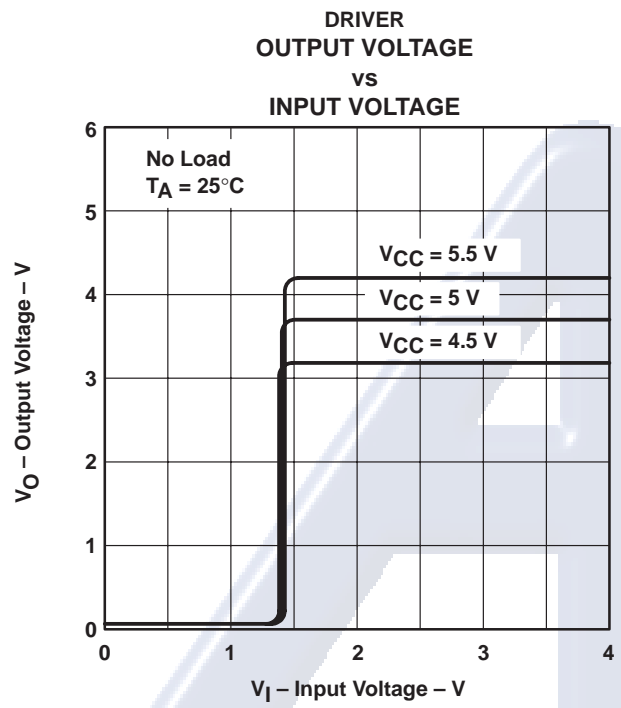

Figure 1

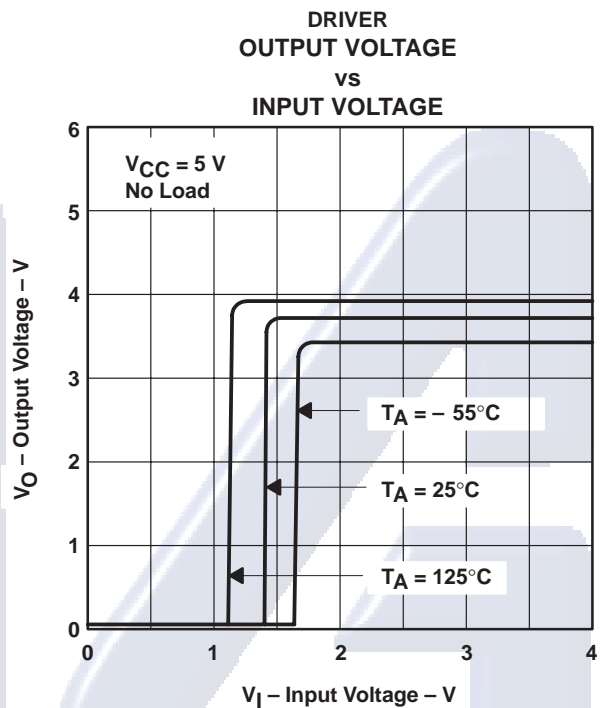

Figure 2

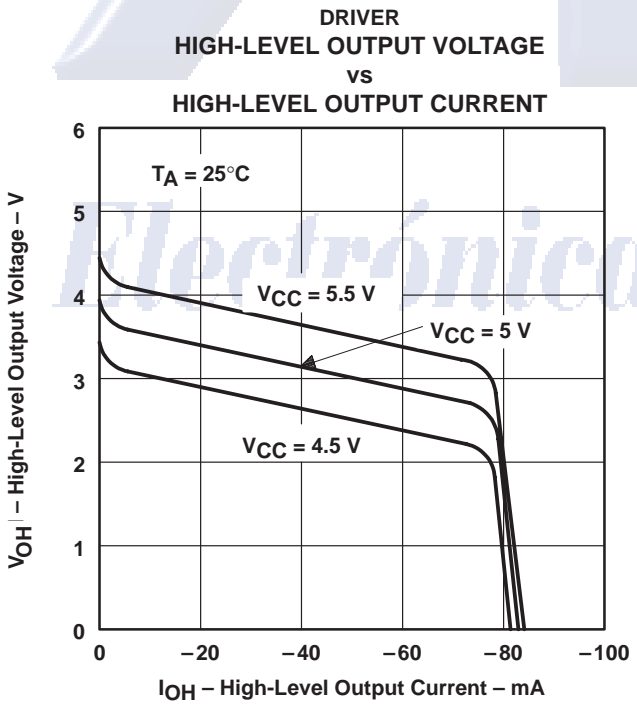

Figure 3

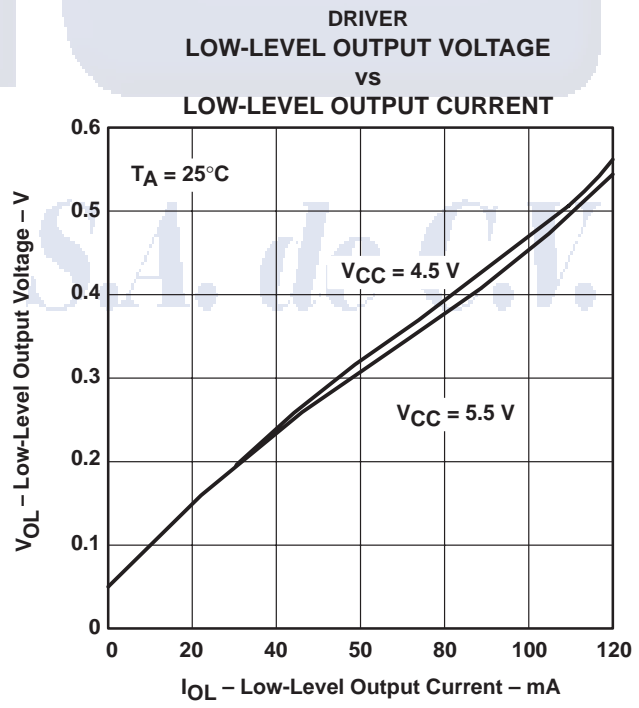

Figure 4

† Operation of the device at these or any other conditions beyond those indicated under "recommended operating conditions" is not implied.



POST OFFICE BOX 655303 • DALLAS, TEXAS 75265

# SN55116, SN75116, SN75117, SN75118, SN75119 DIFFERENTIAL LINE TRANSCEIVERS

SLLS073D – MAY 1976 – REVISED MAY 1998

## TYPICAL CHARACTERISTICS†

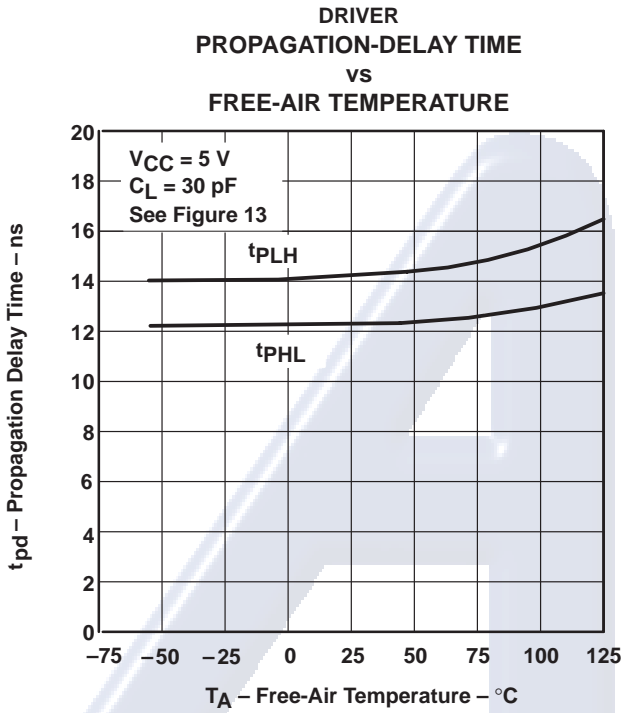
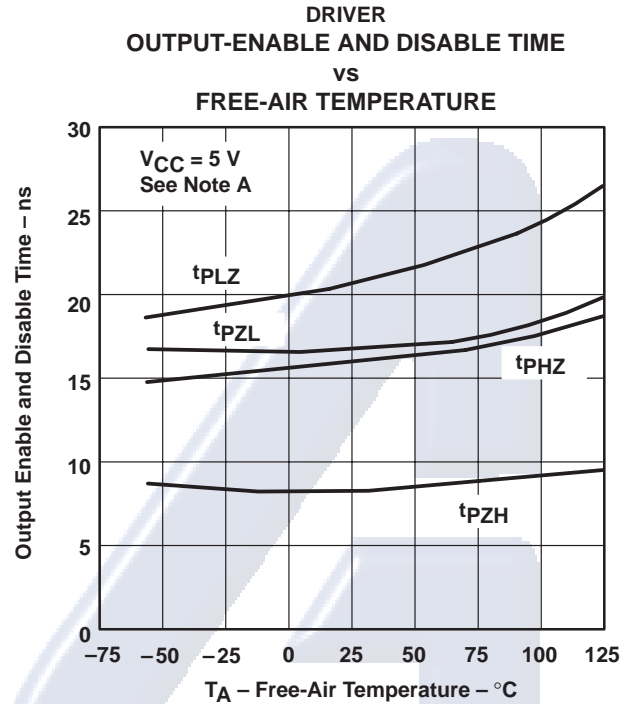

Figure 5



NOTE A: For  $t_{PZH}$  and  $t_{PHZ}$ :  $R_L = 480\ \Omega$ , see Figure 14. For  $t_{PZL}$  and  $t_{PLZ}$ :  $R_L = 250\ \Omega$ , see Figure 15.

Figure 6

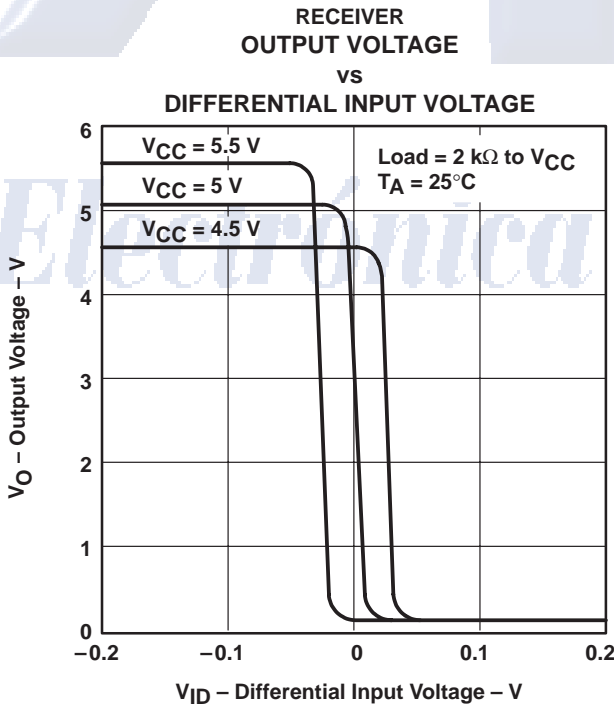

Figure 7

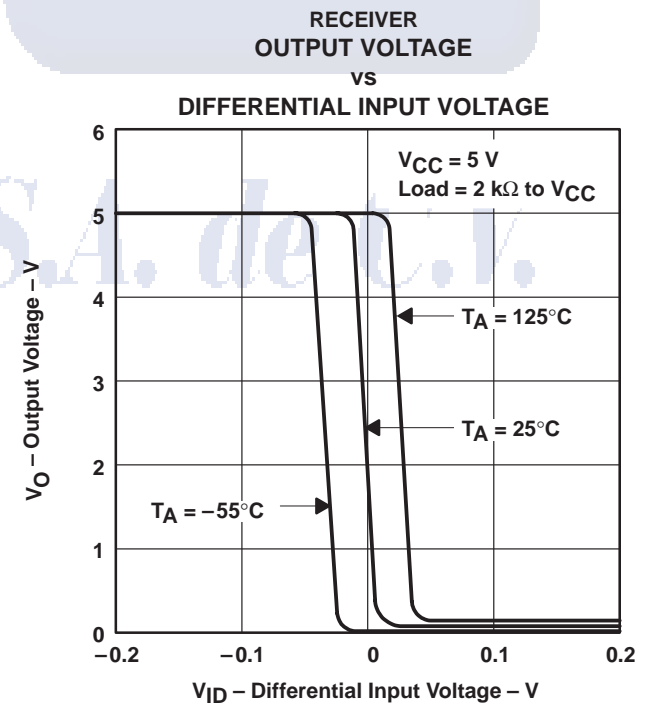

Figure 8

† Operation of the device at these or any other conditions beyond those indicated under "recommended operating conditions" is not implied.

# SN55116, SN75116, SN75117, SN75118, SN75119 DIFFERENTIAL LINE TRANSCEIVERS

SLLS073D – MAY 1976 – REVISED MAY 1998

## TYPICAL CHARACTERISTICS†

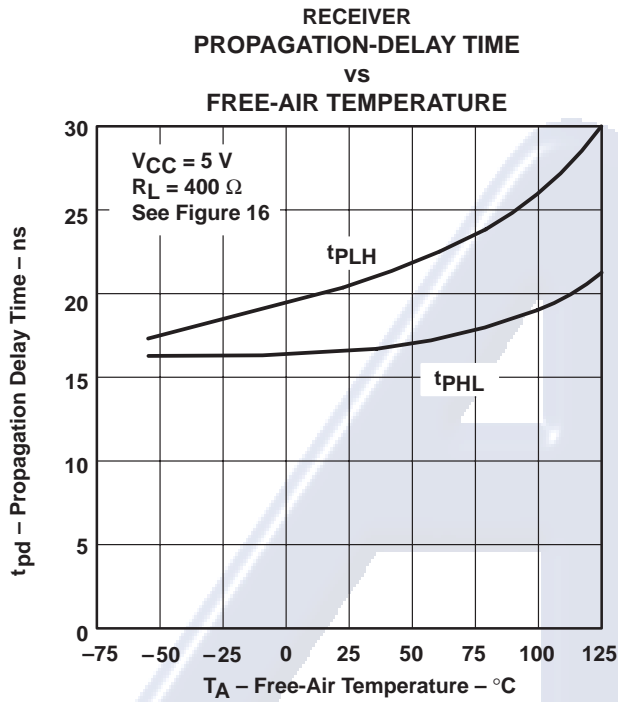
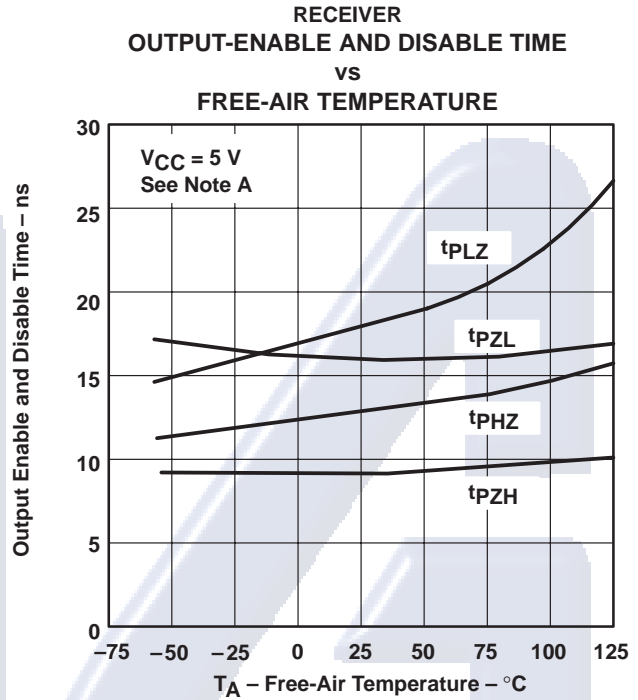

Figure 9



NOTE A: For  $t_{PZH}$  and  $t_{PHZ}$ :  $R_L = 480\ \Omega$ , see Figure 14. For  $t_{PZL}$  and  $t_{PLZ}$ :  $R_L = 250\ \Omega$ , see Figure 15.

Figure 10

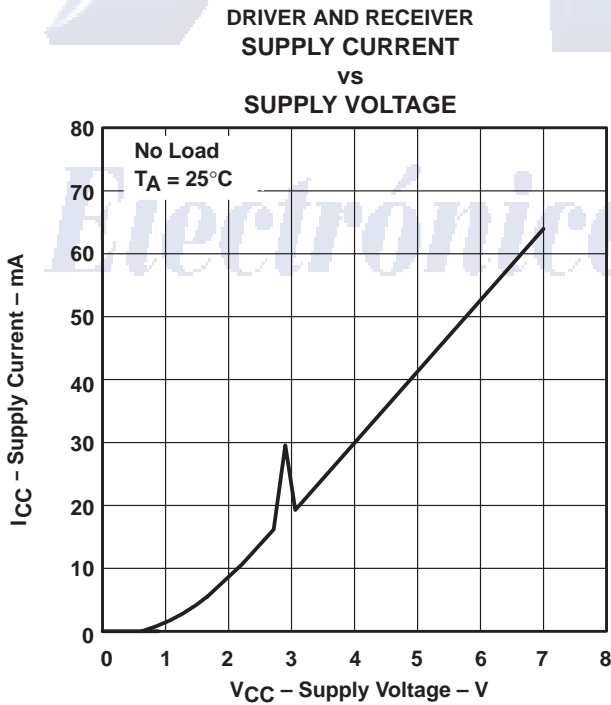

Figure 11

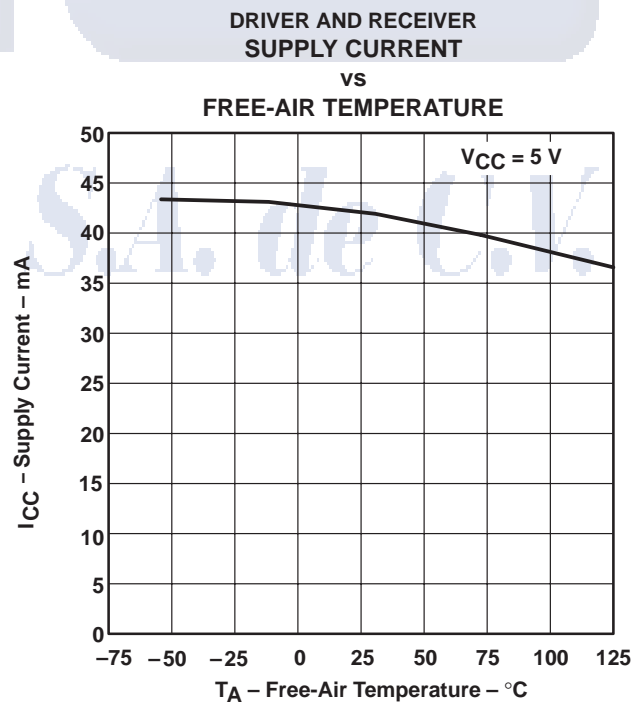

Figure 12

† Operation of the device at these or any other conditions beyond those indicated under "recommended operating conditions" is not implied.

# SN55116, SN75116, SN75117, SN75118, SN75119 DIFFERENTIAL LINE TRANSCEIVERS

SLLS073D – MAY 1976 – REVISED MAY 1998

## PARAMETER MEASUREMENT INFORMATION

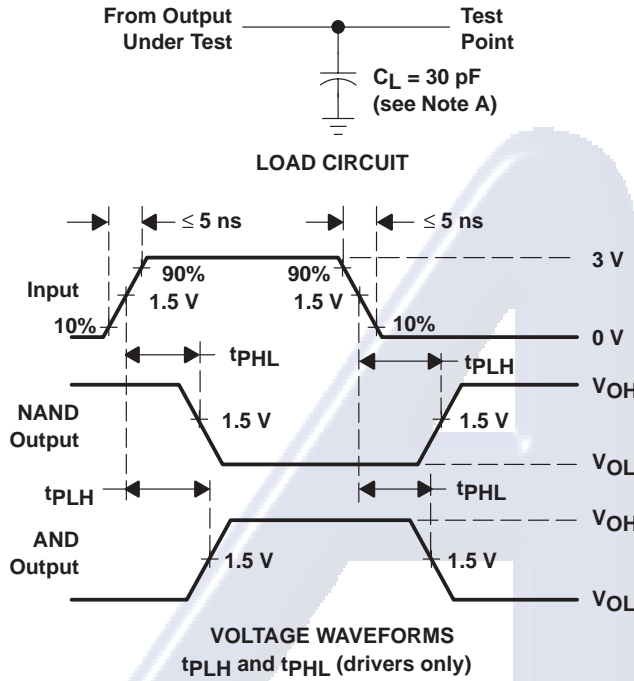

Figure 13

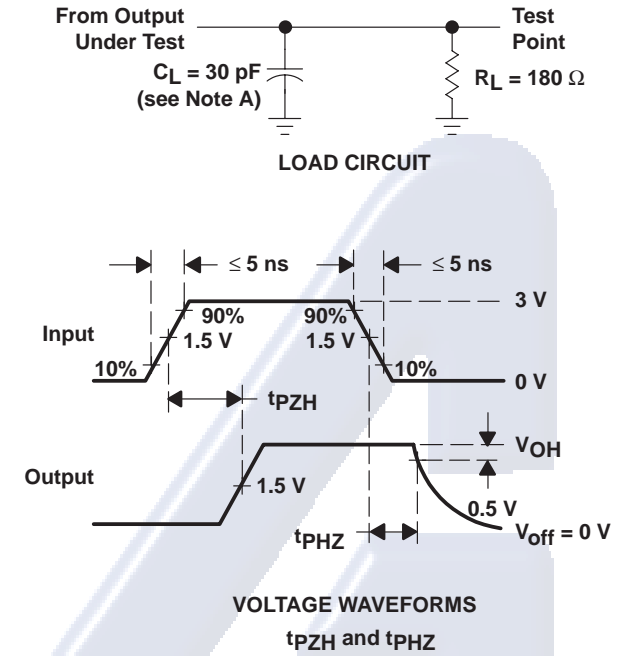

Figure 14

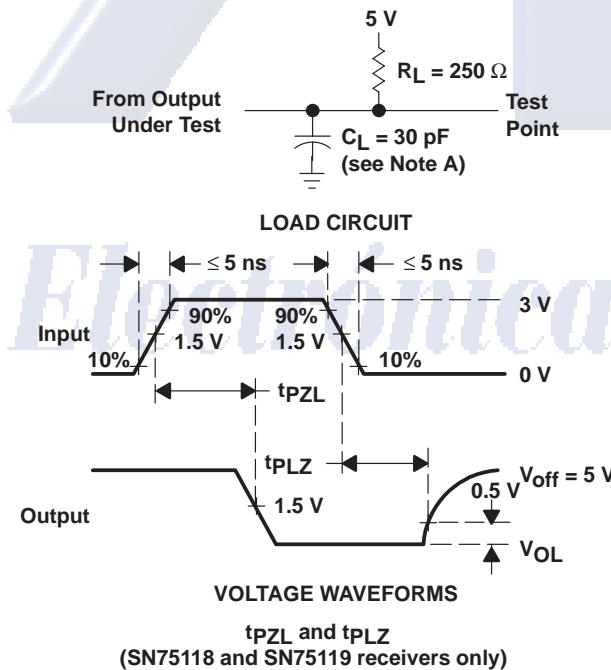

Figure 15

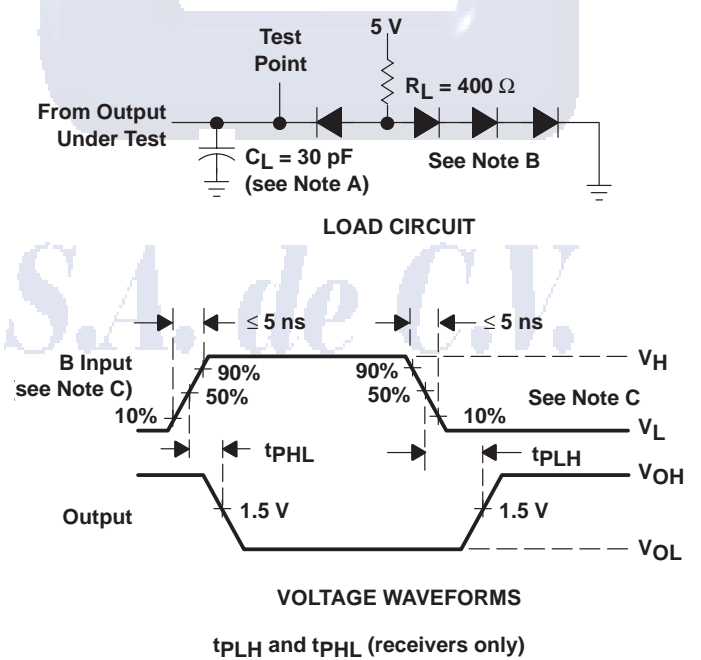

Figure 16

- NOTES: A.  $C_L$  includes probe and jig capacitance.  
 B. All diodes are 1N3064 or equivalent.  
 C. For '116 and SN75118,  $V_H = 3 \text{ V}$ ,  $V_L = -3 \text{ V}$ , the A input is at 0 V.  
 For SN75117 and SN75119,  $V_H = 3 \text{ V}$ ,  $V_L = 0$ , the A input is at 1.5 V.  
 D. When testing the '116 and SN75118 receiver sections, the response-time control and the termination resistor pins are left open.



### IMPORTANT NOTICE

Texas Instruments and its subsidiaries (TI) reserve the right to make changes to their products or to discontinue any product or service without notice, and advise customers to obtain the latest version of relevant information to verify, before placing orders, that information being relied on is current and complete. All products are sold subject to the terms and conditions of sale supplied at the time of order acknowledgement, including those pertaining to warranty, patent infringement, and limitation of liability.

TI warrants performance of its semiconductor products to the specifications applicable at the time of sale in accordance with TI's standard warranty. Testing and other quality control techniques are utilized to the extent TI deems necessary to support this warranty. Specific testing of all parameters of each device is not necessarily performed, except those mandated by government requirements.

CERTAIN APPLICATIONS USING SEMICONDUCTOR PRODUCTS MAY INVOLVE POTENTIAL RISKS OF DEATH, PERSONAL INJURY, OR SEVERE PROPERTY OR ENVIRONMENTAL DAMAGE ("CRITICAL APPLICATIONS"). TI SEMICONDUCTOR PRODUCTS ARE NOT DESIGNED, AUTHORIZED, OR WARRANTED TO BE SUITABLE FOR USE IN LIFE-SUPPORT DEVICES OR SYSTEMS OR OTHER CRITICAL APPLICATIONS. INCLUSION OF TI PRODUCTS IN SUCH APPLICATIONS IS UNDERSTOOD TO BE FULLY AT THE CUSTOMER'S RISK.

In order to minimize risks associated with the customer's applications, adequate design and operating safeguards must be provided by the customer to minimize inherent or procedural hazards.

TI assumes no liability for applications assistance or customer product design. TI does not warrant or represent that any license, either express or implied, is granted under any patent right, copyright, mask work right, or other intellectual property right of TI covering or relating to any combination, machine, or process in which such semiconductor products or services might be or are used. TI's publication of information regarding any third party's products or services does not constitute TI's approval, warranty or endorsement thereof.

*Electrónica S.A. de C.V.*

Copyright © 1998, Texas Instruments Incorporated