



# STGP7NC60H - STGD7NC60H

## N-CHANNEL 14A - 600V TO-220/DPAK

### Very Fast PowerMESH™ IGBT

**Table 1: General Features**

TYPE	V <sub>CES</sub>	V <sub>CE(sat)</sub> (Max) @25°C	I <sub>C</sub> @100°C
STGP7NC60H	600 V	< 2.5 V	14 A
STGD7NC60HT4	600 V	< 2.5 V	14 A

- LOWER ON-VOLTAGE DROP (V<sub>cesat</sub>)
- OFF LOSSES INCLUDE TAIL CURRENT
- LOWER C<sub>RES</sub>/C<sub>IES</sub> RATIO
- HIGH FREQUENCY OPERATION UP TO 70 KHz
- NEW GENERATION PRODUCTS WITH TIGHTER PARAMETER DISTRIBUTION

**DESCRIPTION**

Using the latest high voltage technology based on a patented strip layout, STMicroelectronics has designed an advanced family of IGBTs, the PowerMESH™ IGBTs, with outstanding performances. The suffix "H" identifies a family optimized for high frequency applications in order to achieve very high switching performances (reduced fall) maintaining a low voltage drop.

**APPLICATIONS**

- HIGH FREQUENCY INVERTERS
- SMPS AND PFC IN BOTH HARD SWITCH AND RESONANT TOPOLOGIES
- MOTOR DRIVERS

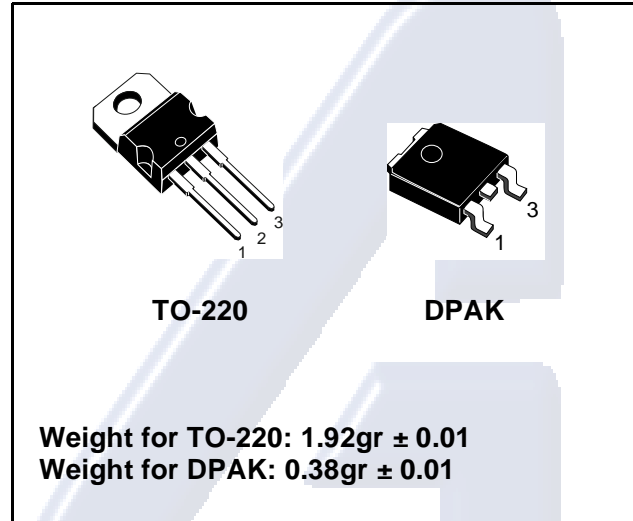
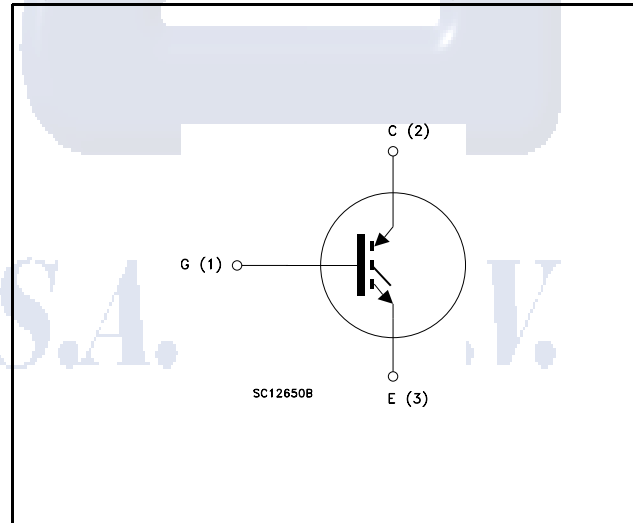
**Figure 1: Package**

**Figure 2: Internal Schematic Diagram**

**Table 2: Order Code**

PART NUMBER	MARKING	PACKAGE	PACKAGING
STGP7NC60H	GP7NC60H	TO-220	TUBE
STGD7NC60HT4	D7NC60H	DPAK	TAPE & REEL

**STGP7NC60H - STGD7NC60H****Table 3: Absolute Maximum ratings**

Symbol	Parameter	Value		Unit
		TO-220	DPAK	
V <sub>CES</sub>	Collector-Emitter Voltage (V <sub>GS</sub> = 0)	600		V
V <sub>ECR</sub>	Emitter-Collector Voltage	20		V
V <sub>GE</sub>	Gate-Emitter Voltage	±20		V
I <sub>C</sub>	Collector Current (continuous) at T <sub>C</sub> = 25°C (#)	25		A
I <sub>C</sub>	Collector Current (continuous) at T <sub>C</sub> = 100°C (#)	14		A
I <sub>CM</sub> (▣)	Collector Current (pulsed)	50		A
P <sub>TOT</sub>	Total Dissipation at T <sub>C</sub> = 25°C	80	70	W
	Derating Factor	0.64	0.56	
T <sub>stg</sub>	Storage Temperature	- 55 to 150		°C
T <sub>j</sub>	Operating Junction Temperature			

(▣) Pulse width limited by max. junction temperature.

**Table 4: Thermal Data**

			Min.	Typ.	Max.	
R <sub>thj-case</sub>	Thermal Resistance Junction-case	TO-220			1.56	°C/W
		DPAK			1.78	
R <sub>thj-amb</sub>	Thermal Resistance Junction-ambient	TO-220			62.5	°C/W
		DPAK			100	
T <sub>L</sub>	Maximum Lead Temperature for Soldering Purpose (1.6 mm from case, for 10 sec.)	TO-220		300		°C
		DPAK		275		

**ELECTRICAL CHARACTERISTICS (T<sub>CASE</sub> = 25°C UNLESS OTHERWISE SPECIFIED)****Table 5: Main Parameters**

Symbol	Parameter	Test Conditions	Min.	Typ.	Max.	Unit
V <sub>BR(CES)</sub>	Collector-Emitter Breakdown Voltage	I <sub>C</sub> = 1 mA, V <sub>GE</sub> = 0	600			V
I <sub>CES</sub>	Collector cut-off Current (V <sub>GE</sub> = 0)	V <sub>CE</sub> = Max Rating, T <sub>C</sub> = 25 °C V <sub>CE</sub> = Max Rating, T <sub>C</sub> = 125 °C			10 1	μA mA
I <sub>GES</sub>	Gate-Emitter Leakage Current (V <sub>CE</sub> = 0)	V <sub>GE</sub> = ± 20V, V <sub>CE</sub> = 0			±100	nA
V <sub>GE(th)</sub>	Gate Threshold Voltage	V <sub>CE</sub> = V <sub>GE</sub> , I <sub>C</sub> = 250 μA	3.75		5.75	V
V <sub>CE(sat)</sub>	Collector-Emitter Saturation Voltage	V <sub>GE</sub> = 15V, I <sub>C</sub> = 7 A		1.85	2.5	V
		V <sub>GE</sub> = 15V, I <sub>C</sub> = 7 A, T <sub>C</sub> = 125°C		1.7		V

(#) Calculated according to the iterative formula:

$$I_C(T_C) = \frac{T_{JMAX} - T_C}{R_{THJ-C} \times V_{CESAT(MAX)}(T_C, I_C)}$$

## ELECTRICAL CHARACTERISTICS (CONTINUED)

Table 6: Dynamic

Symbol	Parameter	Test Conditions	Min.	Typ.	Max.	Unit
$g_{fs}$ (1)	Forward Transconductance	$V_{CE} = 15 \text{ V}$ , $I_C = 7 \text{ A}$		4.30		S
$C_{ies}$	Input Capacitance	$V_{CE} = 25 \text{ V}$ , $f = 1 \text{ MHz}$ , $V_{GE} = 0$		720		pF
$C_{oes}$	Output Capacitance			81		pF
$C_{res}$	Reverse Transfer Capacitance			17		pF
$Q_g$	Total Gate Charge	$V_{CE} = 390 \text{ V}$ , $I_C = 7 \text{ A}$ , $V_{GE} = 15 \text{ V}$ (see Figure 21)		35	48	nC
$Q_{ge}$	Gate-Emitter Charge			7		nC
$Q_{gc}$	Gate-Collector Charge			16		nC
$I_{CL}$	Turn-Off SOA Minimum Current	$V_{clamp} = 480 \text{ V}$ , $T_j = 150^\circ\text{C}$ $R_G = 10 \Omega$ , $V_{GE} = 15 \text{ V}$	50			A

(1) Pulsed: Pulse duration= 300  $\mu\text{s}$ , duty cycle 1.5%

Table 7: Switching On

Symbol	Parameter	Test Conditions	Min.	Typ.	Max.	Unit
$t_{d(on)}$	Turn-on Delay Time	$V_{CC} = 390 \text{ V}$ , $I_C = 7 \text{ A}$ $R_G = 10 \Omega$ , $V_{GE} = 15 \text{ V}$ , $T_j = 25^\circ\text{C}$ (see Figure 18)		18.5		ns
$t_r$	Current Rise Time			8.5		ns
$(di/dt)_{on}$	Turn-on Current Slope			1060		A/ $\mu\text{s}$
$t_{d(on)}$	Turn-on Delay Time	$V_{CC} = 390 \text{ V}$ , $I_C = 7 \text{ A}$ $R_G = 10 \Omega$ , $V_{GE} = 15 \text{ V}$ , $T_j = 125^\circ\text{C}$ (see Figure 19)		18.5		ns
$t_r$	Current Rise Time			7		ns
$(di/dt)_{on}$	Turn-on Current Slope			1000		A/ $\mu\text{s}$

Table 8: Switching Off

Symbol	Parameter	Test Conditions	Min.	Typ.	Max.	Unit
$t_r(V_{off})$	Off Voltage Rise Time	$V_{CC} = 390 \text{ V}$ , $I_C = 7 \text{ A}$ , $R_G = 10 \Omega$ , $V_{GE} = 15 \text{ V}$ $T_j = 25^\circ\text{C}$ (see Figure 19)		27		ns
$t_{d(off)}$	Turn-off Delay Time			72		ns
$t_f$	Current Fall Time			60		ns
$t_r(V_{off})$	Off Voltage Rise Time	$V_{CC} = 390 \text{ V}$ , $I_C = 7 \text{ A}$ , $R_G = 10 \Omega$ , $V_{GE} = 15 \text{ V}$ $T_j = 125^\circ\text{C}$ (see Figure 19)		56		ns
$t_{d(off)}$	Turn-off Delay Time			116		ns
$t_f$	Current Fall Time			105		ns

Table 9: Switching Energy

Symbol	Parameter	Test Conditions	Min.	Typ.	Max	Unit
$E_{on}$ (2)	Turn-on Switching Losses	$V_{CC} = 390 \text{ V}$ , $I_C = 7 \text{ A}$ $R_G = 10 \Omega$ , $V_{GE} = 15 \text{ V}$ , $T_j = 25^\circ\text{C}$ (see Figure 19)		95	125	$\mu\text{J}$
$E_{off}$ (3)	Turn-off Switching Loss			115	150	$\mu\text{J}$
$E_{ts}$	Total Switching Loss			210	275	$\mu\text{J}$
$E_{on}$ (2)	Turn-on Switching Losses	$V_{CC} = 390 \text{ V}$ , $I_C = 7 \text{ A}$ $R_G = 10 \Omega$ , $V_{GE} = 15 \text{ V}$ , $T_j = 125^\circ\text{C}$ (see Figure 19)		140		$\mu\text{J}$
$E_{off}$ (3)	Turn-off Switching Loss			215		$\mu\text{J}$
$E_{ts}$	Total Switching Loss			355		$\mu\text{J}$

2)  $E_{on}$  is the turn-on losses when a typical diode is used in the test circuit in figure 2. If the IGBT is offered in a package with a co-pack diode, the co-pack diode is used as external diode. IGBTs & DIODE are at the same temperature ( $25^\circ\text{C}$  and  $125^\circ\text{C}$ )

(3) Turn-off losses include also the tail of the collector current.

# STGP7NC60H - STGD7NC60H

Figure 3: Output Characteristics

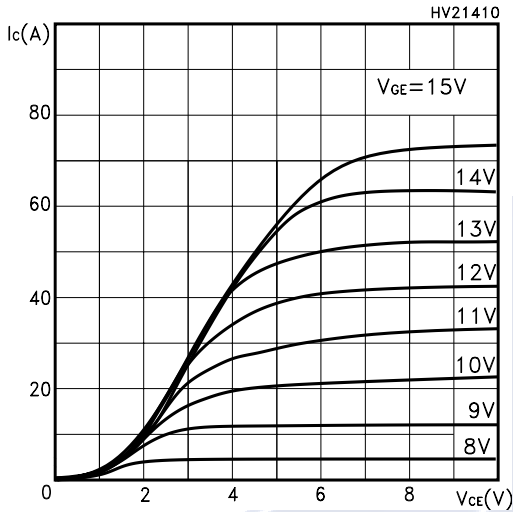

Figure 4: Transconductance

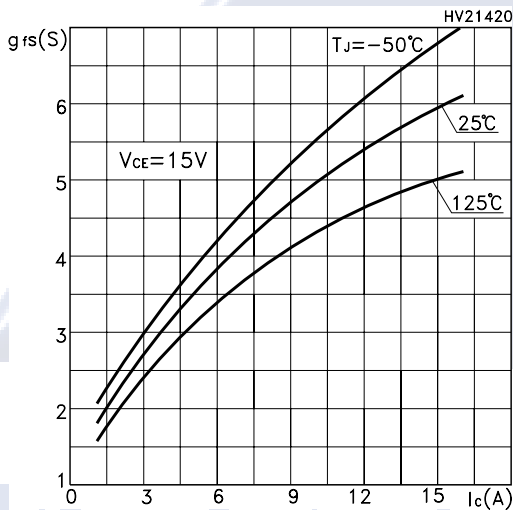

Figure 5: Collector-Emitter On Voltage vs Collector Current

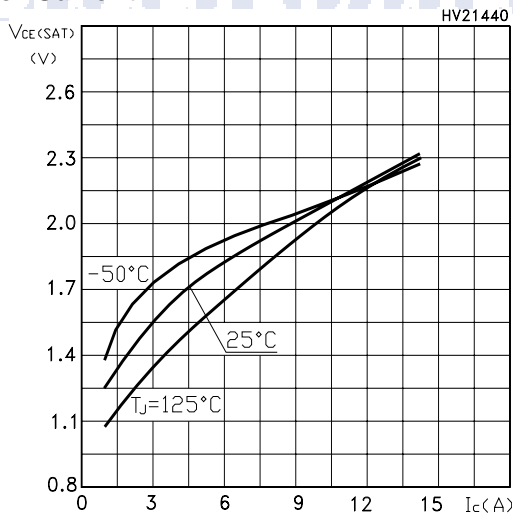

Figure 6: Transfer Characteristics

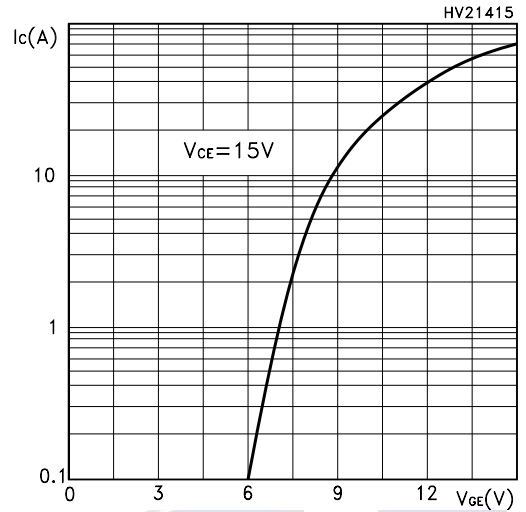

Figure 7: Collector-Emitter On Voltage vs Temperature

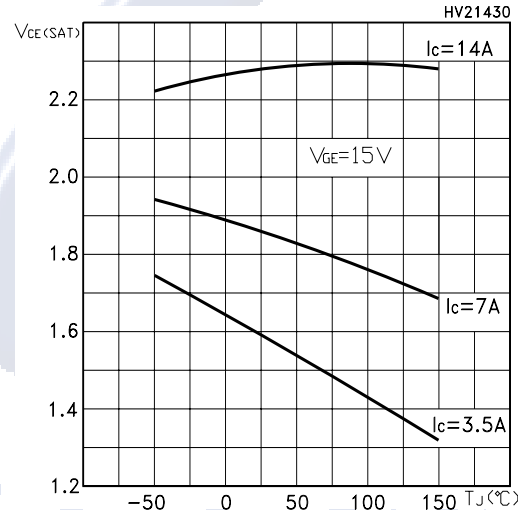
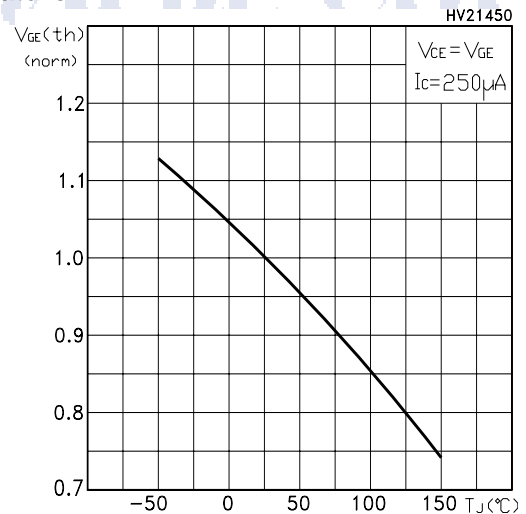

Figure 8: Normalized Gate Threshold vs Temperature



STGP7NC60H - STGD7NC60H

Figure 9: Normalized Breakdown Voltage vs Temperature

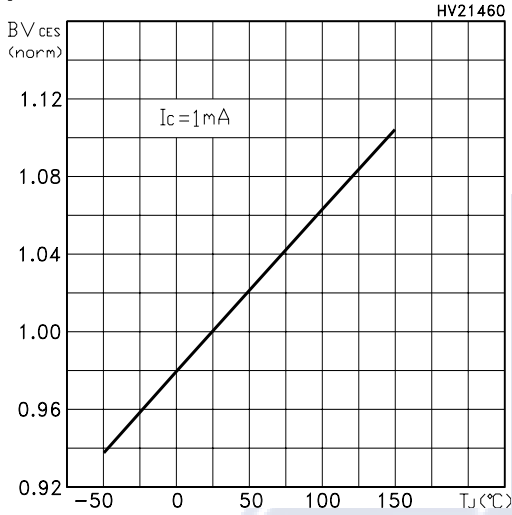

Figure 10: Capacitance Variations

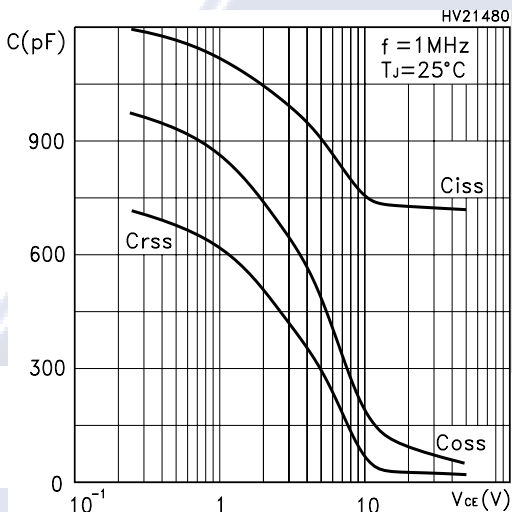

Figure 11: Total Switching Losses vs Gate Resistance

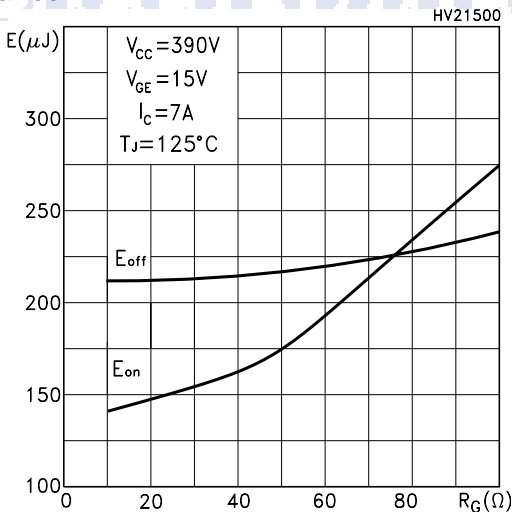

Figure 12: Gate Charge vs Gate-Emitter Voltage

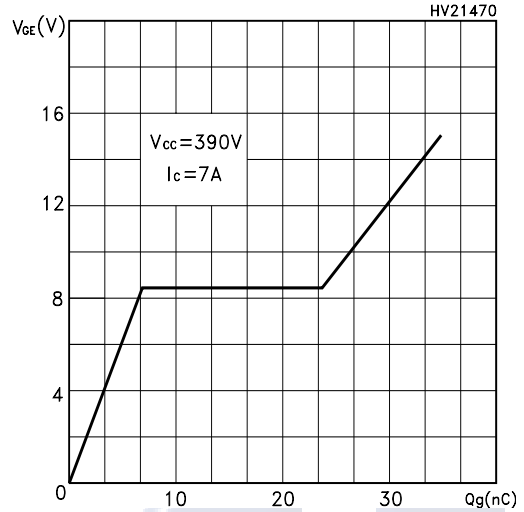

Figure 13: Total Switching Losses vs Temperature

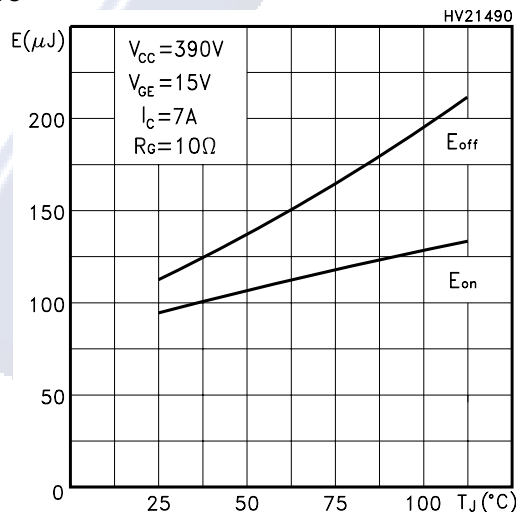
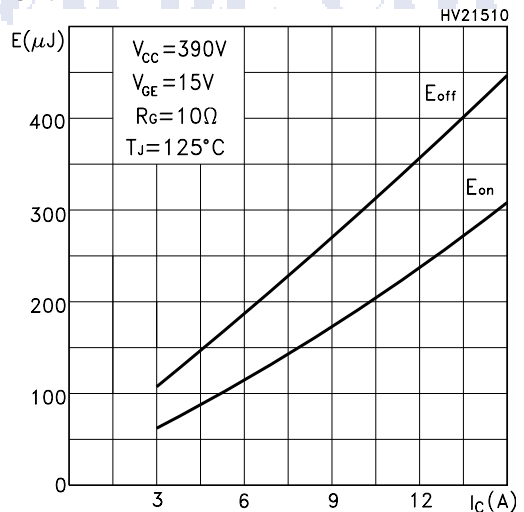
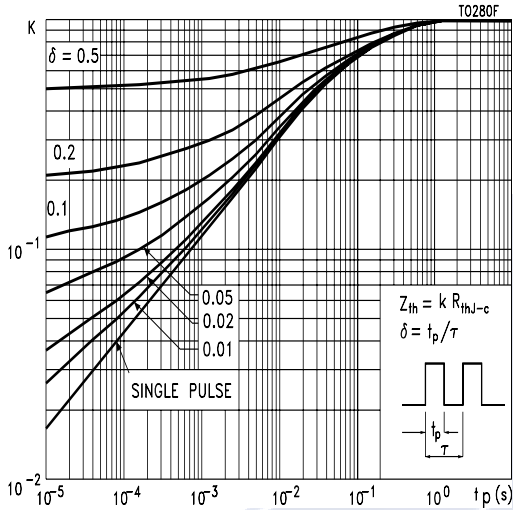

Figure 14: Total Switching Losses vs Collector Current



**STGP7NC60H - STGD7NC60H**

**Figure 15: Thermal Impedance for TO-220**



**Figure 16: Thermal Impedance for DPAK**

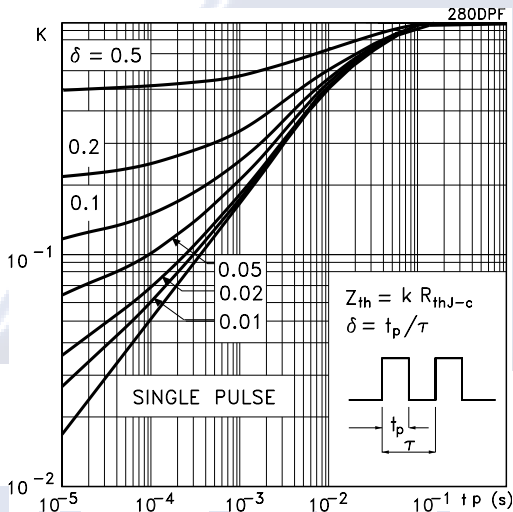

**Figure 17: Turn-Off SOA**

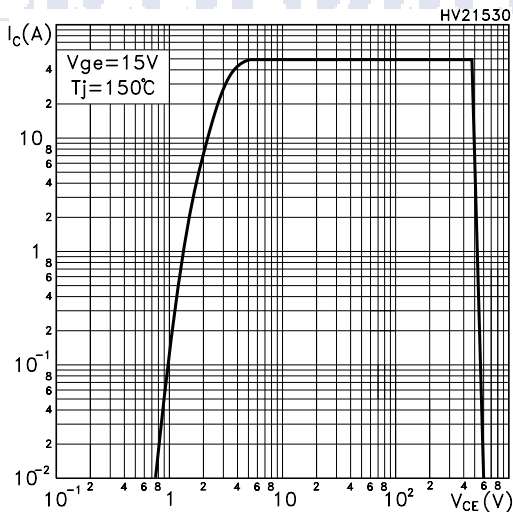

**Figure 18: Ic vs Frequency**

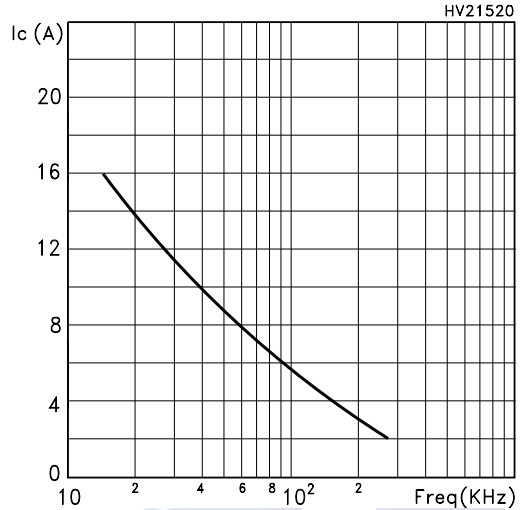

For a fast IGBT suitable for high frequency applications, the typical collector current vs. maximum operating frequency curve is reported. That frequency is defined as follows:

$$f_{MAX} = (P_D - P_C) / (E_{ON} + E_{OFF})$$

1) The maximum power dissipation is limited by maximum junction to case thermal resistance:

$$P_D = \Delta T / R_{THJ-C}$$

considering  $\Delta T = T_J - T_C = 125^\circ C - 75^\circ C = 50^\circ C$

2) The conduction losses are:

$$P_C = I_C * V_{CE(SAT)} * \delta$$

with 50% of duty cycle,  $V_{CESAT}$  typical value @ 125°C.

3) Power dissipation during ON & OFF commutations is due to the switching frequency:

$$P_{SW} = (E_{ON} + E_{OFF}) * freq.$$

4) Typical values @ 125°C for switching losses are used (test conditions:  $V_{CE} = 390V$ ,  $V_{GE} = 15V$ ,  $R_G = 3.3 \text{ Ohm}$ ). Furthermore, diode recovery energy is included in the  $E_{ON}$  (see note 2), while the tail of the collector current is included in the  $E_{OFF}$  measurements (see note 3).

STGP7NC60H - STGD7NC60H

Figure 19: Test Circuit for Inductive Load Switching

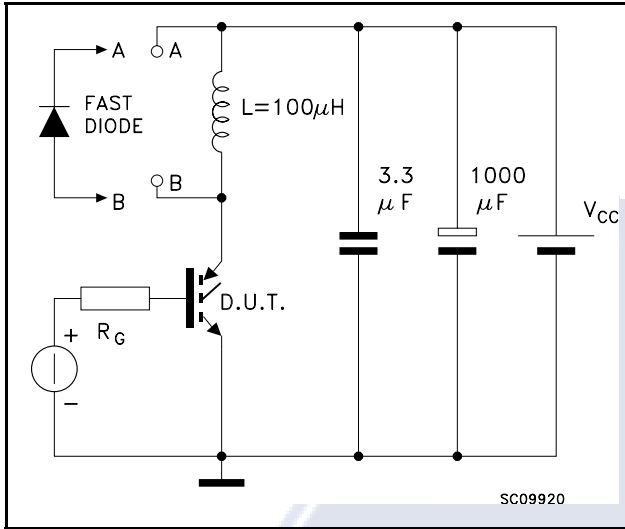

Figure 20: Switching Waveforms

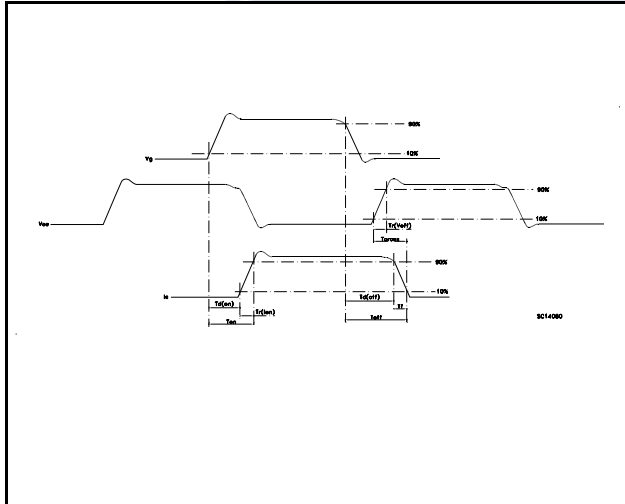
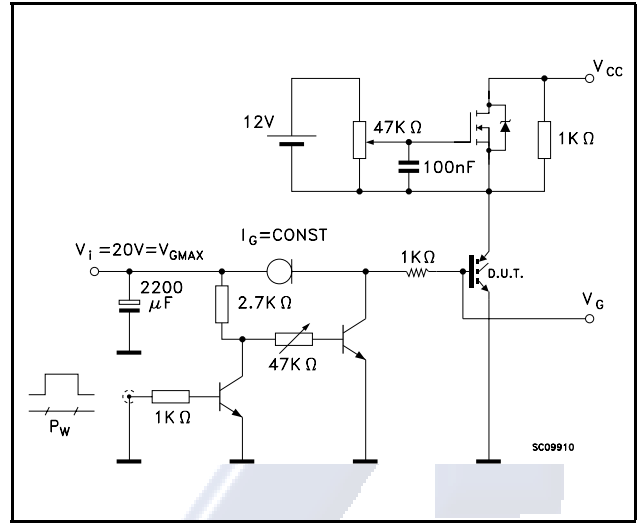

Figure 21: Gate Charge Test Circuit



Electronica S.A. de C.V.

**STGP7NC60H - STGD7NC60H****TO-220 MECHANICAL DATA**

DIM.	mm.			inch		
	MIN.	TYP.	MAX.	MIN.	TYP.	MAX.
A	4.40		4.60	0.173		0.181
b	0.61		0.88	0.024		0.034
b1	1.15		1.70	0.045		0.066
c	0.49		0.70	0.019		0.027
D	15.25		15.75	0.60		0.620
E	10		10.40	0.393		0.409
e	2.40		2.70	0.094		0.106
e1	4.95		5.15	0.194		0.202
F	1.23		1.32	0.048		0.052
H1	6.20		6.60	0.244		0.256
J1	2.40		2.72	0.094		0.107
L	13		14	0.511		0.551
L1	3.50		3.93	0.137		0.154
L20		16.40			0.645	
L30		28.90			1.137	
øP	3.75		3.85	0.147		0.151
Q	2.65		2.95	0.104		0.116

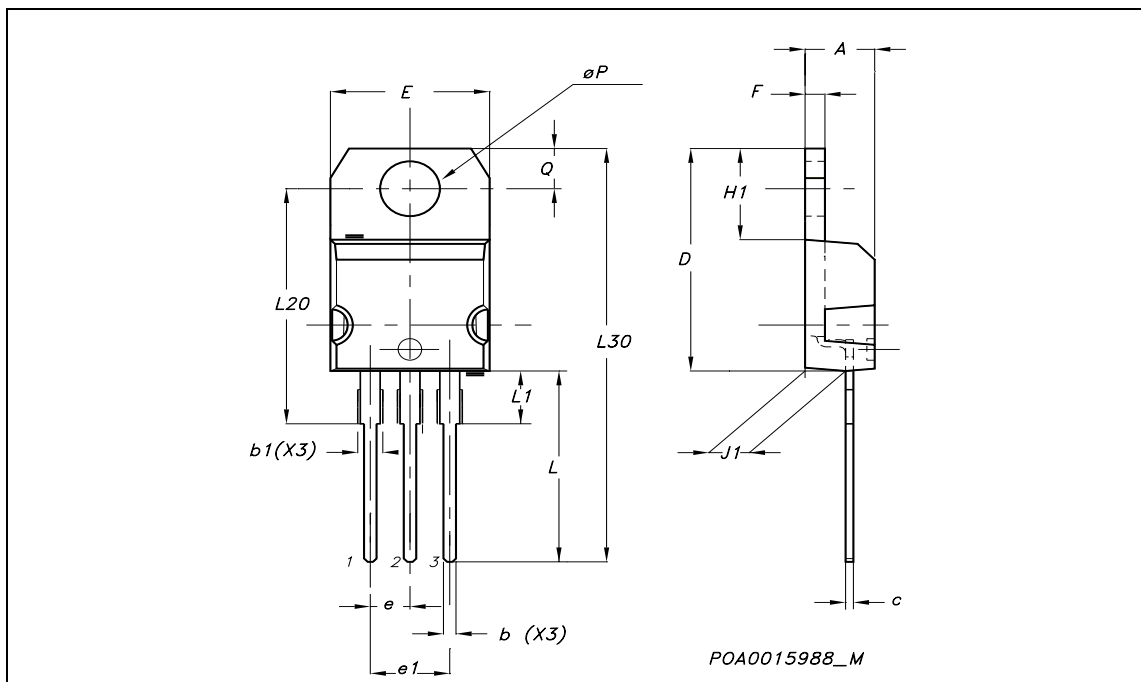



**STGP7NC60H - STGD7NC60H**

**TO-252 (DPAK) MECHANICAL DATA**

DIM.	mm			inch		
	MIN.	TYP.	MAX.	MIN.	TYP.	MAX.
A	2.20		2.40	0.087		0.094
A1	0.90		1.10	0.035		0.043
A2	0.03		0.23	0.001		0.009
B	0.64		0.90	0.025		0.035
B2	5.20		5.40	0.204		0.213
C	0.45		0.60	0.018		0.024
C2	0.48		0.60	0.019		0.024
D	6.00		6.20	0.236		0.244
E	6.40		6.60	0.252		0.260
G	4.40		4.60	0.173		0.181
H	9.35		10.10	0.368		0.398
L2		0.8			0.031	
L4	0.60		1.00	0.024		0.039
V2	0°		8°	0°		0°

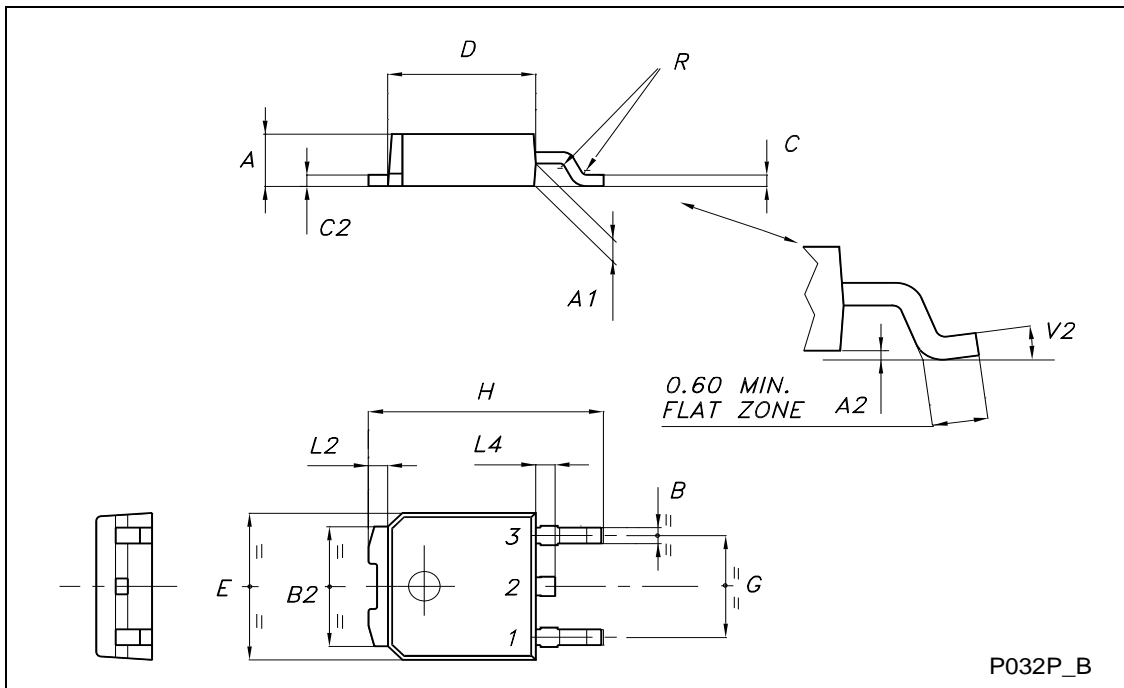

# STGP7NC60H - STGD7NC60H

## DPAK FOOTPRINT

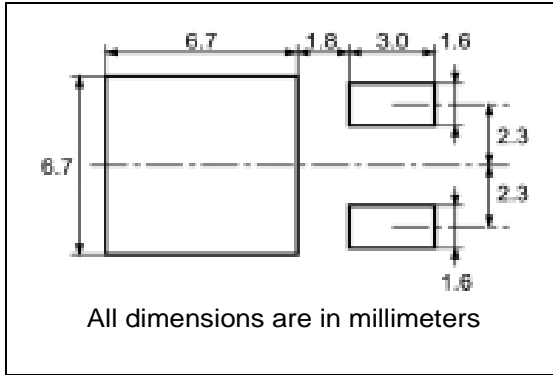

## TAPE AND REEL SHIPMENT

### REEL MECHANICAL DATA

DIM.	mm		inch	
	MIN.	MAX.	MIN.	MAX.
A		330		12.992
B	1.5		0.059	
C	12.8	13.2	0.504	0.520
D	20.2		0.795	
G	16.4	18.4	0.645	0.724
N	50		1.968	
T		22.4		0.881

### TAPE MECHANICAL DATA

DIM.	mm		inch	
	MIN.	MAX.	MIN.	MAX.
A0	6.8	7	0.267	0.275
B0	10.4	10.6	0.409	0.417
B1		12.1		0.476
D	1.5	1.6	0.059	0.063
D1	1.5		0.059	
E	1.65	1.85	0.065	0.073
F	7.4	7.6	0.291	0.299
K0	2.55	2.75	0.100	0.108
P0	3.9	4.1	0.153	0.161
P1	7.9	8.1	0.311	0.319
P2	1.9	2.1	0.075	0.082
R	40		1.574	
W	15.7	16.3	0.618	0.641

### BASE QTY

2500
------

### BULK QTY

2500
------

**Table 10: Revision History**

Date	Revision	Description of Changes
20-Aug-2004	1	New datasheet
09-Jun-2005	2	Modified title



*Electrónica S.A. de C.V.*

## STGP7NC60H - STGD7NC60H

---

Information furnished is believed to be accurate and reliable. However, STMicroelectronics assumes no responsibility for the consequences of use of such information nor for any infringement of patents or other rights of third parties which may result from its use. No license is granted by implication or otherwise under any patent or patent rights of STMicroelectronics. Specifications mentioned in this publication are subject to change without notice. This publication supersedes and replaces all information previously supplied. STMicroelectronics products are not authorized for use as critical components in life support devices or systems without express written approval of STMicroelectronics.

The ST logo is a registered trademark of STMicroelectronics

All other names are the property of their respective owners

© 2005 STMicroelectronics - All Rights Reserved

STMicroelectronics group of companies

Australia - Belgium - Brazil - Canada - China - Czech Republic - Finland - France - Germany - Hong Kong - India - Israel - Italy - Japan - Malaysia - Malta - Morocco - Singapore - Spain - Sweden - Switzerland - United Kingdom - United States of America