

D.P.P.
Dual Power Pack

thick film hybrid

OUTPUT STAGE OF AF POWER AMP.

Features

General output stage of power amplifier has a difficult and complex problem about heat sink designing and its setting. Sanyo's D.P.P. intends to decrease electronic parts and rationalize a manufacturing process by designing IC of only output stage of power amplifier.

- IMST system.
- Output stage for AF high power amplifier.
- Dual power supply.

- Darlington type pure / quasi-complementary circuit.
- These same pin assignment and pin interval lead to standardize a printed board.
- Metal substrate use IMST[®] makes good thermal stability.
- Able to design freely previous section of power amplifier. This leads tone control designing.

Type Number		Maximum Ratings at Ta=25°C										Operation Characteristics at Ta=25°C		
		Case Outline	Maximum Supply Voltage V _{CCmax}	Junction Temperature T _J	Storage Temperature T _{stg}	Thermal Resistance, θ	Collector Current, I _{Cmax}	Allowable Load Shorting Time, t _s	Supply Voltage at Rated Power, V _{CE}	Output Power, P _o f _r =20 to 20kHz	Total Harmonic Distortion THD(f _r =20 to 20kHz)	Quiescent Current, I _{CCQ}	Equivalent Circuit	
Pure-Complementary Circuit	Quasi-Complementary Circuit	V	°C	°C	°C/W	A	sec	V	W	%	mA			
1-Channel Darlington Power Pack (Without emitter resistance)														
STK 0030	STK 0025	4002	±35	150	-30 to +105	2.6	3	2	±24.4	23 min.	0.05 max.	40 typ, 80 max.		
	STK 0029	4002	±37	150	-30 to +105	2.4	5	2	±25.0	25 min.	0.1 max.	40 typ, 80 max.		
STK 0040	STK 0039	4002	±40	150	-30 to +105	2.4	4	2	±28.5	30 min.	0.1 max.	40 typ, 80 max.		
		4004	±45	150	-30 to +105	2.0	5	2	±31	35 min.	0.1 max.	40 typ, 80 max.		
STK 0050	STK 0049	4002	±48	150	-30 to +105	2.0	5	2	±33	40 min.	0.1 max.	40 typ, 80 max.		
		4004	±50	150	-30 to +105	1.8	5	2	±35	45 min.	0.1 max.	40 typ, 80 max.		
STK 0060	STK 0059	4004	±53	150	-30 to +105	1.8	5	2	±36	50 min.	0.1 max.	40 typ, 80 max.		
		4004	±52.5	150	-30 to +105	1.6	7	—	±38	55 min.	0.1 max.	40 typ, 80 max.		
STK 0070	STK 0105	4006	±55	150	-30 to +105	1.4	7	—	±40	60 min.	0.1 max.	40 typ, 80 max.		
		4006	±55	150	-30 to +105	1.4	7	—	±43	70 min.	0.1 max.	40 typ, 80 max.		
STK 0080	STK 0105	4006	±65	150	-30 to +105	1.3	10	—	±46	80 min.	0.1 max.	40 typ, 80 max.		
		4007	±75	150	-30 to +105	1.0	10	—	±50	100 min.	0.1 max.	40 typ, 80 max.		
STK 0040II		4002	±48	150	-30 to +105	1.8	5	1	±36	40 min.	0.01 max.	40 typ, 70 max.		
STK 0050II		4004	±53	150	-30 to +105	1.6	6	1	±39	50 min.	0.01 max.	40 typ, 70 max.		
STK 0060II		4006	±55	150	-30 to +105	1.3	8	1	±41	60 min.	0.01 max.	40 typ, 70 max.		
STK 0070II		4006	±60	150	-30 to +105	1.3	10	1	±45	70 min.	0.01 max.	40 typ, 70 max.		
STK 0080II		4006	±65	150	-30 to +105	1.2	12	1	±47	80 min.	0.01 max.	40 typ, 70 max.		
1-Channel Darlington Power Pack (With emitter resistance)														
STK 1030	STK 1035	4004	±40	150	-30 to +105	2.4	5	2	±28.5	30 min.	0.02 max.	40 typ, 80 max.		
		4004	±40	150	-30 to +105	2.4	5	2	±28.5	30 min.	0.02 max.	40 typ, 80 max.		
STK 1040	STK 1039	4004	±46.1	150	-30 to +105	1.85	6	2	±30	35 min.	0.02 max.	40 typ, 80 max.		
		4004	±48	150	-30 to +105	1.8	7	2	±33	40 min.	0.02 max.	40 typ, 80 max.		
STK 1050	STK 1049	4004	±48	150	-30 to +105	1.8	7	2	±33	40 min.	0.02 max.	40 typ, 80 max.		
		4004	±50	150	-30 to +105	1.8	7	2	±34	45 min.	0.02 max.	40 typ, 80 max.		
STK 1060	STK 1059	4004	±53	150	-30 to +105	1.8	7	2	±36	50 min.	0.02 max.	40 typ, 80 max.		
		4004	±53	150	-30 to +105	1.6	7	—	±38	55 min.	0.02 max.	40 typ, 80 max.		
		4004	±56	150	-30 to +105	1.6	10	—	±40	60 min.	0.02 max.	40 typ, 80 max.		
STK 1050II		4020	±55	150	-30 to +105	1.6	6	1	±38	50 min.	0.01 max.	40 typ, 70 max.		
STK 1060II		4020	±56	150	-30 to +105	1.3	8	1	±40	60 min.	0.01 max.	40 typ, 70 max.		
STK 1070II		4020	±63	150	-30 to +105	1.3	10	1	±43	70 min.	0.01 max.	40 typ, 70 max.		
STK 1080II		4020	±65	150	-30 to +105	1.2	10	1	±45	80 min.	0.01 max.	40 typ, 70 max.		
2-Channel Darlington Power Pack (Without emitter resistance)														
	STK 2025	4015	±40	150	-30 to +105	2.6	3	2	±24	20x2 min.	0.02 max.	40 typ, 80 max.		
	STK 2029	4015	±43	150	-30 to +105	2.2	4	2	±25.5	25x2 min.	0.02 max.	40 typ, 80 max.		
2-Channel Darlington Power Pack (With emitter resistance)														
STK 2230	STK 2135	4015	±48	150	-30 to +105	2.1	4	2	±28.5	30x2 min.	0.02 max.	40 typ, 80 max.		
		4015	±50	150	-30 to +105	1.85	5	2	±30	35x2 min.	0.02 max.	40 typ, 80 max.		
STK 2240	STK 2145	4015	±54	150	-30 to +105	1.8	7	2	±32	40x2 min.	0.02 max.	40 typ, 80 max.		
		4015	±48	150	-30 to +105	2.1	4	2	±30	30x2 min.	0.01 max.	35 typ, 80 max.		
STK 2250	STK 2145	4015	±54	150	-30 to +105	1.8	5	2	±33.5	40x2 min.	0.01 max.	35 typ, 80 max.		
		4015	±59	150	-30 to +105	1.8	5	2	±37	50x2 min.	0.01 max.	35 typ, 80 max.		
1-Channel No Switching Darlington Power Pack														
STK 8250		4006	±56	150	-30 to +105	1.8	5	2	±38	50 min.	0.01 max.	80 max.		
STK 8260		4006	±59	150	-30 to +105	1.4	7	2	±42	60 min.	0.01 max.	80 max.		
STK 8270		4006	±60	150	-30 to +105	1.4	7	2	±44	70 min.	0.01 max.	80 max.		
STK 8280		4006	±65	150	-30 to +105	1.4	7	2	±47	80 min.	0.01 max.	80 max.		
STK 8250II		4020	±55	150	-30 to +105	1.6	6	1	±38	50 min.	0.005 max.	70 max.		
STK 8260II		4020	±56	150	-30 to +105	1.3	8	1	±40	60 min.	0.005 max.	40 typ, 70 max.		
STK 8270II		4020	±63	150	-30 to +105	1.3	10	1	±44	70 min.	0.005 max.	40 typ, 70 max.		
STK 8280II		4020	±65	150	-30 to +105	1.2	12	1	±45	80 min.	0.01 max.	70 max.		

Shown on the next page.

Series
check



EQUIVALENT CIRCUIT

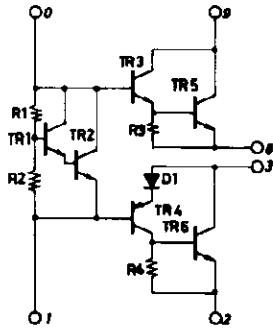

STK 0025, 0029, 0039, 0049, 0059

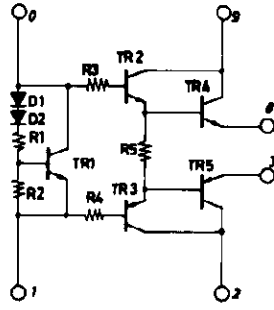

STK 0030, 0040, 0050, 0060, 0070, 0080,

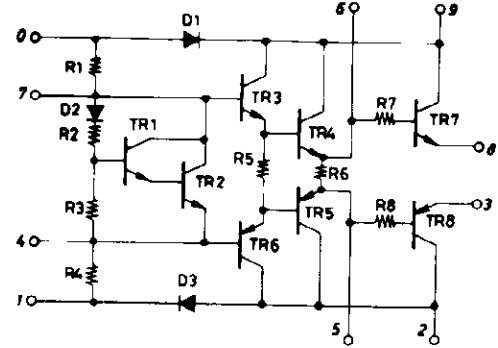

STK 0040II, 0050II, 0060II, 0070II, 0080II

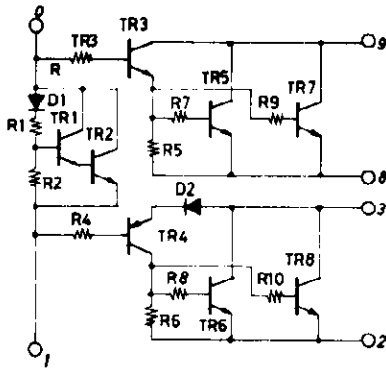

STK 0105

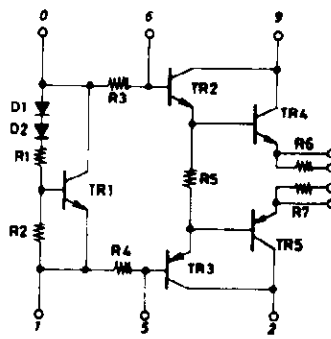

STK 1030, 1040, 1050, 1060

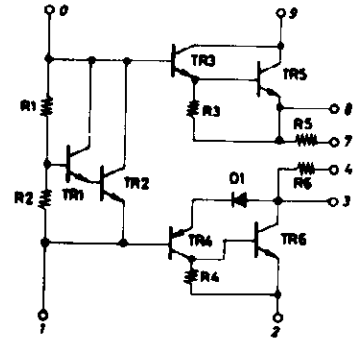

STK 1035, 1039, 1045, 1049, 1059

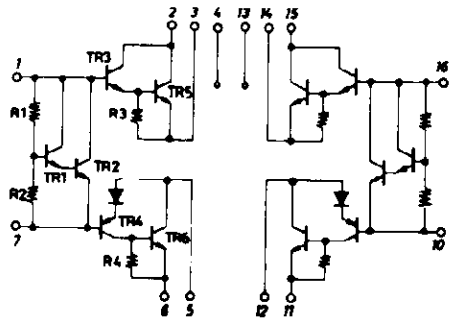

STK 2025, 2029

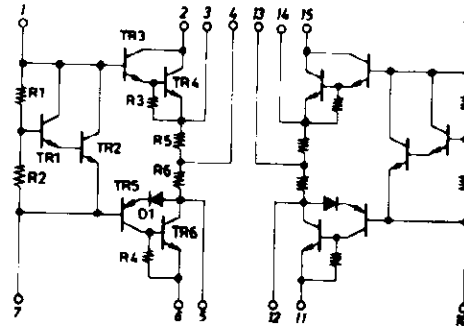

STK 2135, 2139, 2145

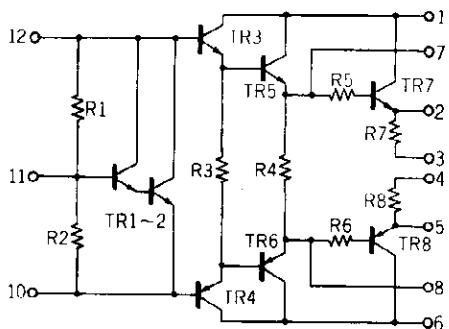

STK 1050II, 1060II, 1070II, 1080II

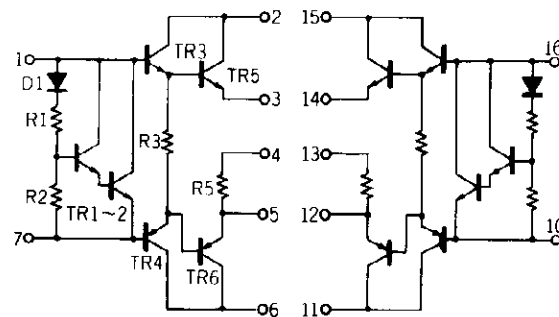

STK 2230, 2240, 2250