

STK404-130S — Thick-Film Hybrid IC — One-Channel Class AB Audio Power Amplifier IC 100W

Overview

The STK404-000S series products are audio power amplifier hybrid ICs that consist of optimally-designed discrete component power amplifier circuits that have been miniaturized using SANYO's unique insulated metal substrate technology (IMST). The adoption of a newly-developed low thermal resistance substrate allows this series of devices to be provided in miniature packages significantly more compact than earlier Sanyo products with similar specifications.

Features

- Series of pin compatible power amplifiers ranging from 45W to 180W (10%/1kHz) devices. The same printed circuit board can be used depending on the output power grade.
- Miniature packages
 - 30W to 40W (THD=0.4%, f=20Hz to 20kHz); 44.0mm × 25.6mm × 8.5mm *
 - 50W to 80W (THD=0.4%, f=20Hz to 20kHz); 46.6mm × 25.5mm × 8.5mm *
 - 100W to 120W (THD=0.4%, f=20Hz to 20kHz); 59.2mm × 25.5mm × 8.5mm *
- *: Not including the pins.
- Output load impedance: $R_L=6\Omega$
- Allowable load shorted time: 0.3 seconds
- Built-in thermal protection circuit
- Supports the use of standby, muting, and load shorting protection circuits.

Series Organization

These products are organized as a series based on their output capacity.

Item	Type No.						
	STK404-050S	STK404-070S	STK404-090S	STK404-100S	STK404-120S	STK404-130S	STK404-140S
Output 1 (0.4%/20Hz to 20kHz)	30W	40W	50W	60W	80W	100W	120W
Output 2 (10%/1kHz)	45W	60W	80W	90W	120W	150W	180W
Maximum supply voltage (6Ω)	±37V	±43V	±46V	±51V	±59V	±64V	±73V
Recommended supply voltage (6Ω)	±26V	±30V	±32V	±35V	±41V	±45V	±51V
Remarks	—		Built-in thermal protection circuit				
Package	44.0mm × 25.6mm × 8.5mm		46.6mm × 25.5mm × 8.5mm			59.2mm × 25.5mm × 8.5mm	

- Any and all SANYO products described or contained herein do not have specifications that can handle applications that require extremely high levels of reliability, such as life-support systems, aircraft's control systems, or other applications whose failure can be reasonably expected to result in serious physical and/or material damage. Consult with your SANYO representative nearest you before using any SANYO products described or contained herein in such applications.
- SANYO assumes no responsibility for equipment failures that result from using products at values that exceed, even momentarily, rated values (such as maximum ratings, operating condition ranges, or other parameters) listed in products specifications of any and all SANYO products described or contained herein.

STK404-130S

Specifications

Maximum Ratings at $T_a = 25^\circ\text{C}$

Parameter	Symbol	Conditions	Ratings	Unit
Maximum supply voltage (No signal)	$V_{CC \text{ max}(0)}$		± 70	V
Maximum supply voltage	$V_{CC \text{ max}(1)}$	$R_L=6\Omega$	± 64	V
Thermal sensor maximum voltage	V_p	Between pins 1 and 2	16	V
Thermal sensor maximum current	I_p	Between pins 1 and 2	30	mA
Thermal resistance	θ_{j-c}	Per power transistor	1.3	$^\circ\text{C}/\text{W}$
Junction temperature	$T_j \text{ max}$	Both the $T_j \text{ max}$ and the $T_c \text{ max}$ conditions must be met.	150	$^\circ\text{C}$
IC substrate operating temperature	$T_c \text{ max}$		125	$^\circ\text{C}$
Thermal sensor operating temperature *2	$T_p \text{ max}$		145	$^\circ\text{C}$
Storage temperature	T_{stg}		-30 to +125	$^\circ\text{C}$
Allowable load shorted time *4	t_s	$V_{CC}=\pm 45.0\text{V}$, $R_L=6\Omega$, $f=50\text{Hz}$, $P_O=100\text{W}$	0.3	s

Operating Characteristics at $T_c=25^\circ\text{C}$, $R_L=6\Omega$ (noninductive load), $R_g=600\Omega$, $V_G=30\text{dB}$

Parameter	Symbol	Conditions*1				Ratings			Unit	
		V_{CC} (V)	f (Hz)	P_O (W)	THD (%)	min	typ	max		
Output power	$P_O(1)$	± 45.0	20 to 20 k		0.4	100			W	
	$P_O(2)$	± 45.0	1 k		10		150			
Frequency characteristics	f_L, f_H	± 45.0		1.0		+0 -3 dB	20 to 20 k		Hz	
Input impedance	r_i	± 45.0	1 k	1.0			55		$k\Omega$	
Output noise voltage *3	V_{NO}	± 54.0				$R_g = 10 k\Omega$	1.2		mVrms	
Quiescent current	I_{CCO}	± 54.0				No loading		50	mA	
Neutral voltage	V_N	± 54.0					-100	0	+100	mV
Thermal sensor resistance	R_p	$T_p=25^\circ\text{C}$, between pins 1 and 2					470		Ω	
Thermal sensor temperature	T_p	$R_p=4.7k\Omega$, between pins 1 and 2					145		$^\circ\text{C}$	

Notes: 1. Unless otherwise noted, use a constant-voltage supply for the power supply used during inspection.

2. The thermal sensor temperature (+125 to +145 $^\circ\text{C}$) is designed to prevent incorrect operation, but does not guarantee continued operation of the hybrid IC. The total integrated time this device spends operating in the temperature range +125 to +145 $^\circ\text{C}$ must not exceed 12 hours.

3. The output noise voltage values shown are peak values read with a VTVM. However, an AC stabilized (50Hz) power supply should be used to minimize the influence of AC primary side flicker noise on the reading.

4. Use the transformer power supply circuit shown in the figure below for allowable load shorted time measurement and output noise voltage measurement. This IC is designed assuming that applications will provide a load-shorting protection function that operates within 0.3 seconds of the load being shorted and that either cuts off power to the IC or eliminates the load-short state in some other manner.

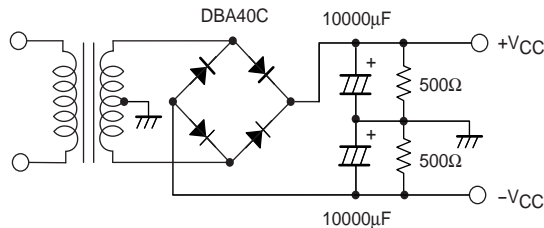

Designated Transformer Power Supply (MG-250 equivalent)

Package Dimensions

unit : mm

4205

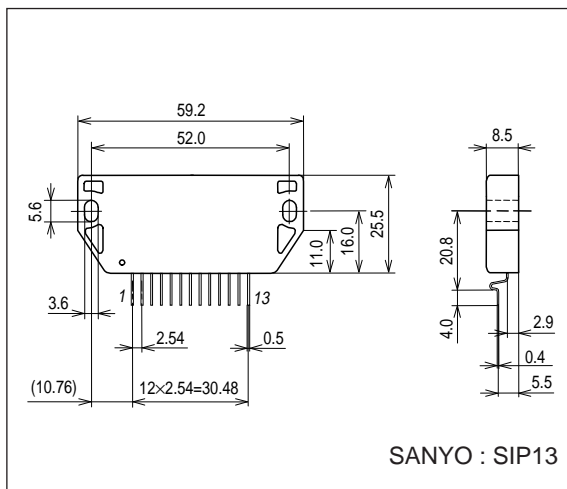

STK404-130S

Internal Equivalent Circuit

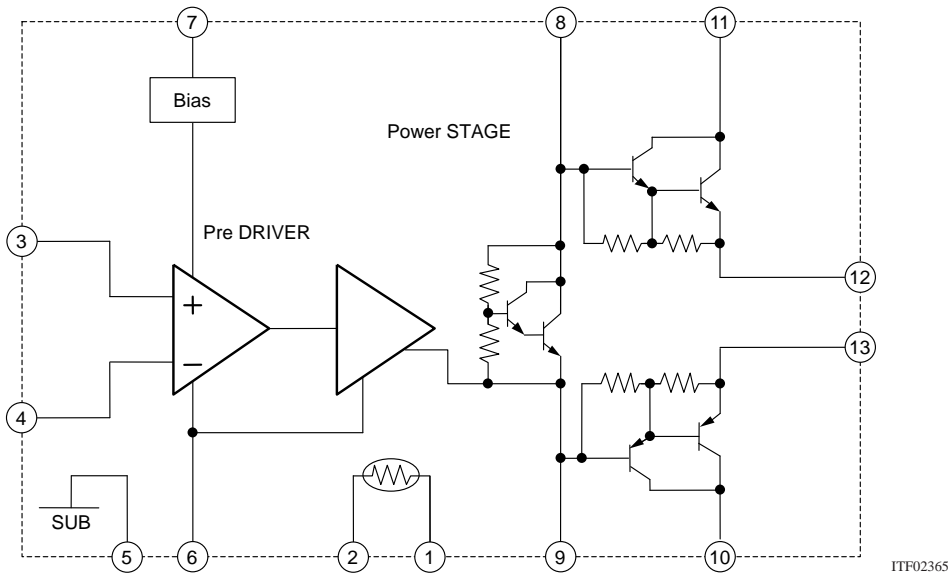

Sample Application Circuit

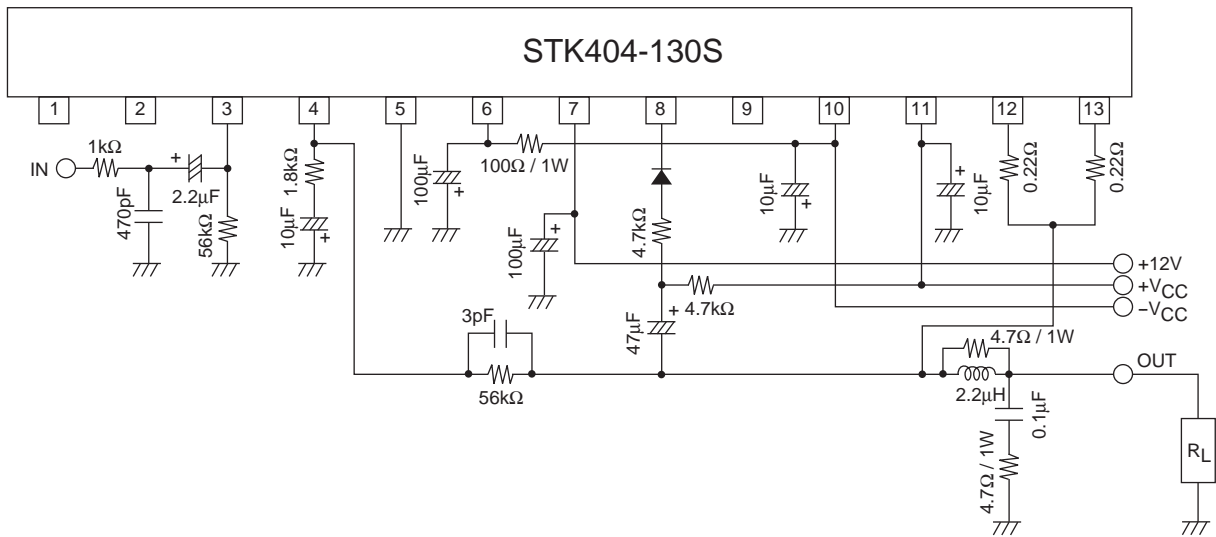

Thermal Design Example

If we define P_d , the total power dissipation on the board when this hybrid IC is in operation, the heat sink thermal resistance, θ_{c-a} , is determined as follows:

Condition 1: The hybrid IC substrate temperature T_c must not exceed 125°C.

$$P_d \times \theta_{c-a} + T_a < 125^\circ\text{C} \dots (1)$$

T_a : Guaranteed ambient temperature for the end product.

Condition 2: The junction temperature of each transistor must not exceed 150°C.

$$P_d \times \theta_{c-a} + P_d/N \times \theta_{j-c} + T_a < 150^\circ\text{C} \dots (2)$$

N : Number of power transistors

θ_{j-c} : Thermal resistance per power transistor

We take the power dissipation in the power transistors to be P_d evenly distributed across those N power transistors.

If we solve for θ_{c-a} in equations (1) and (2), we get the following inequalities:

$$\theta_{c-a} < (125 - T_a)/P_d \dots (3)$$

$$\theta_{c-a} < (150 - T_a)/P_d - \theta_{j-c}/N \dots (4)$$

Values that satisfy both these inequalities at the same time are the required heat sink thermal resistance values.

Example:

For actual music signals, it is usual to use a P_d of 1/8 of P_{Omax} , which is the power estimated for continuous signals in this manner. (Note that depending on the particular safety standard used, a value somewhat different from the value of 1/8 used here may be used.)

When $V_{CC} = \pm 45\text{V}$ and $R_L = 6\Omega$, we get the following expression for the total power dissipation on the board, P_d :

$$P_d = 47 \text{ W (when } 1/8 P_{Omax} \text{ is } 12.5 \text{ W)} \dots (5)$$

The number, N , of power transistors in the hybrid IC's audio amplifier block is 2. Since the thermal resistance, θ_{j-c} , per transistor is 1.3°C/W, the required heat sink thermal resistance, θ_{c-a} , for a guaranteed ambient temperature of 50°C will be as follows:

$$\text{From inequality (3): } \theta_{c-a} < (125 - 50)/47 = 1.59 \dots (6)$$

$$\text{From inequality (4): } \theta_{c-a} < (150 - 50)/47 - 1.3/2 = 1.48 \dots (7)$$

Therefore, the thermal resistance that satisfies both these expressions (6,7) at the same time is 1.48°C/W.

Note that this thermal design example assumes the use of a constant-voltage power supply, and is only provided as an example for reference purposes. Thermal designs must be tested in an actual end product.

