

Thick Film Hybrid IC

SANYO	No. 5081	STK392-040
		3-Channel Convergence Correction Circuit (I_C max = 7A)

Overview

The STK392-040 is a convergence correction circuit IC for video projectors. It incorporates three output amplifiers in a single package, making possible the construction of CRT horizontal and vertical convergence correction output circuits for each of the RGB colors using just two hybrid ICs.

Applications

- Video projectors (high-definition television, high-definition graphic projectors)

Features

- 3 output amplifier circuits in a single package (22-pin)
- High absolute maximum supply voltage (V_{CC} max = $\pm 50V$)
- Low thermal resistance (θ_{j-c} = $1.8^{\circ}C/W$)
- High temperature stability (T_C max = $125^{\circ}C$)
- Separate predriver and output stage supplies
- Output stage supply switching for high-performance designs
- Pins are arranged in separate groups of inputs, supply, and outputs to reduce the adverse effects of pattern layout on characteristics and to make design easier.
- Constant-current circuit in the predriver for stable supply switching operation
- Large lineup of family devices (STK392-000 series) to cover the range from general applications to high-class applications using a single PCB

Package Dimensions

unit: mm

4086A

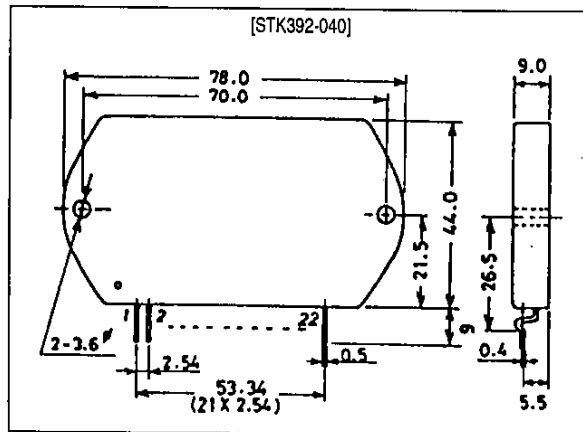

SANYO Electric Co., Ltd. Semiconductor Business Headquarters
TOKYO OFFICE Tokyo Bldg., 1-10, 1 Chome, Ueno, Taito-ku, TOKYO, 110 JAPAN

61995TH (ID) No. 5081-1/4

STK392-040

Specifications

Maximum Ratings at Ta = 25°C

Parameter	Symbol	Conditions	Ratings	Unit
Maximum supply voltage	V _{CC} max		±50	V
Maximum collector current	I _C	Tr8, 10, 18, 20, 28, 30	7.0	A
Thermal resistance	θ _{j-c}	Tr8, 10, 18, 20, 28, 30 (per transistor)	1.8	°C/W
Junction temperature	T _J		150	°C
Operating substrate temperature	T _c		125	°C
Storage temperature	T _{stg}		-30 to +125	°C

Operating Characteristics at Ta = 25°C, R_g = 50Ω

Parameter	Symbol	Conditions	min	typ	max	Unit
Output noise voltage	V _{NO}	V _{CC} = ±40V	-	-	0.2	mVrms
Quiescent current	I _{CCO}	V _{CC} = ±40V	30	90	150	mA
Neutral voltage	V _N	V _{CC} = ±40V	-50	0	+50	mV
Output delay lime	t _D	V _{CC} = ±40V, f = 64kHz, triangular wave input, V _{OUT} = 1.5Vp-p	-	-	0.2	μs
Frequency response	f _H	V _{CC} = ±35V, -3dB, (0dB at 1kHz), sine wave input, V _{in} = 50mVp-p	-	3.6	-	MHz

Block Diagram

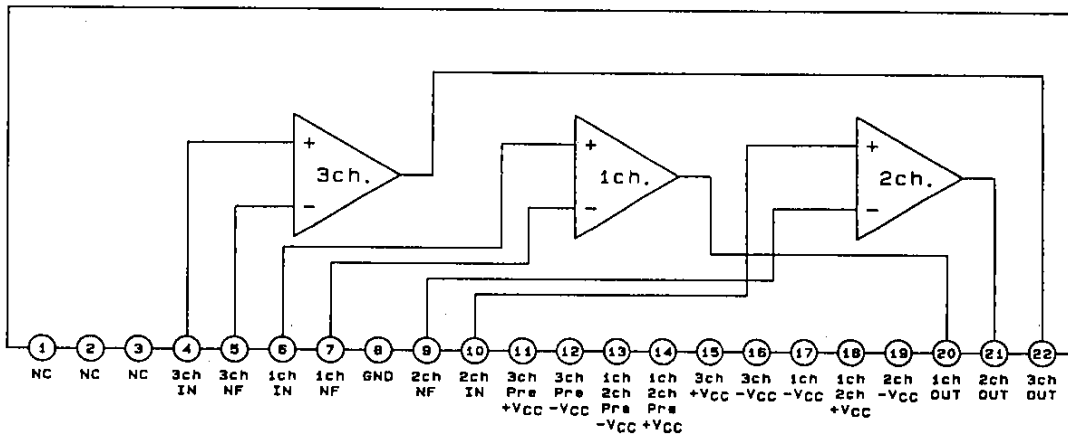

A01699

STK392-040

Equivalent Circuit

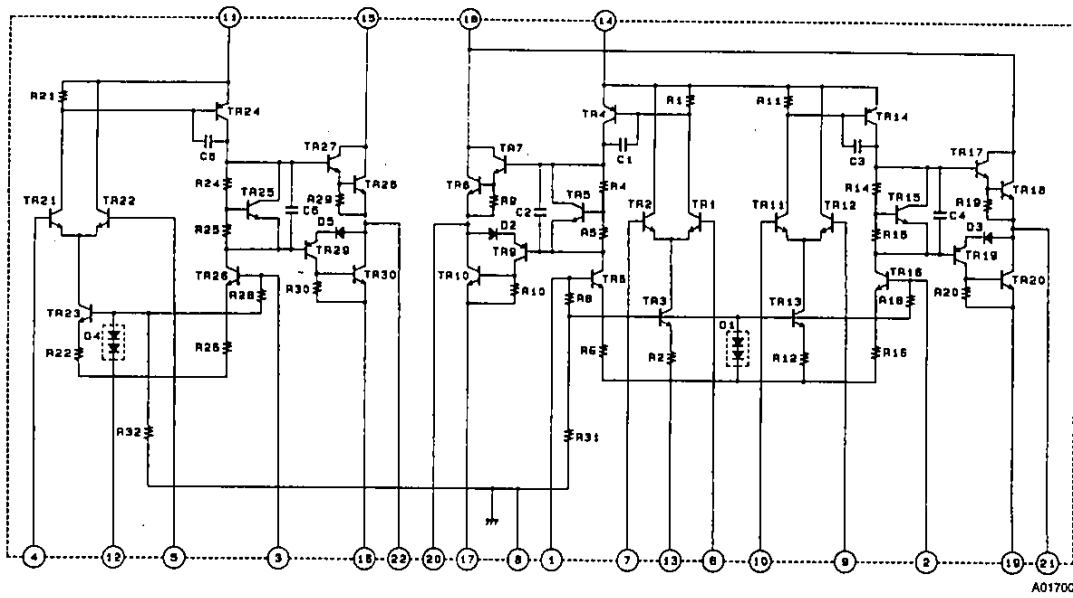

Test Circuit

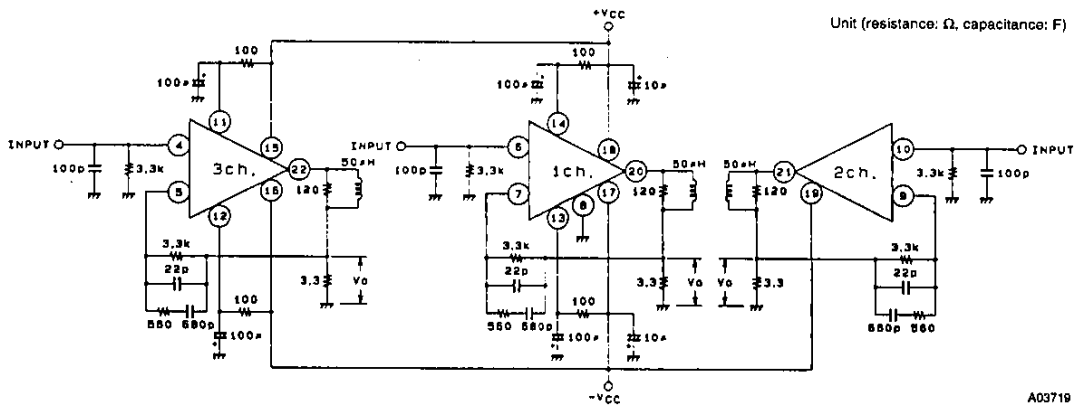

Vo: V_{NO} is measured by connecting a VTVM.
 V_N is measured by connecting a DC voltmeter.
 I_D is measured by connecting an oscilloscope.

STK392-040

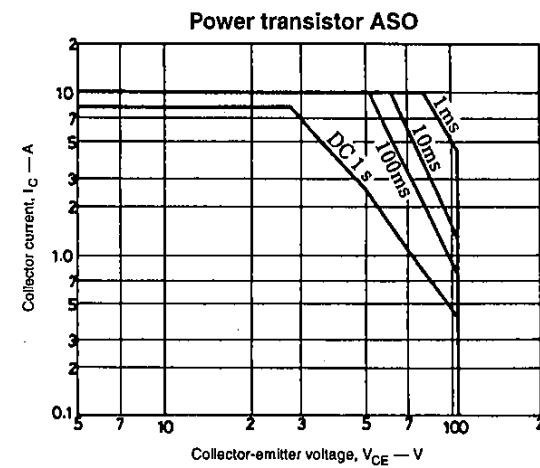
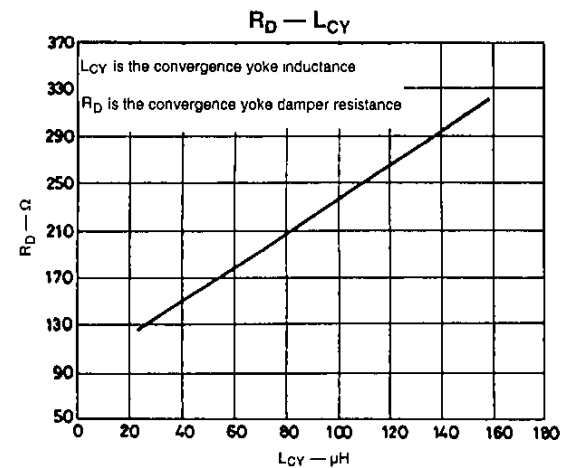
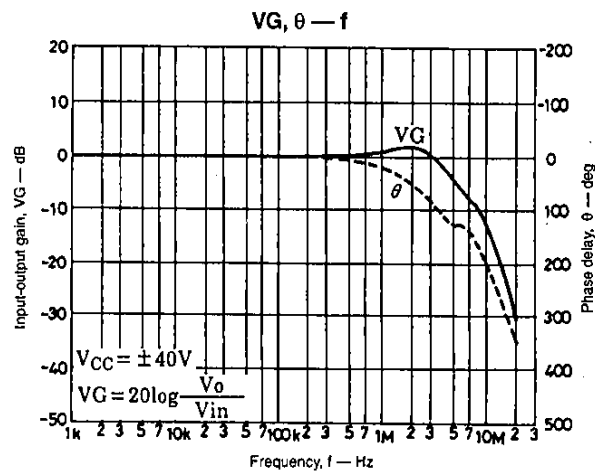
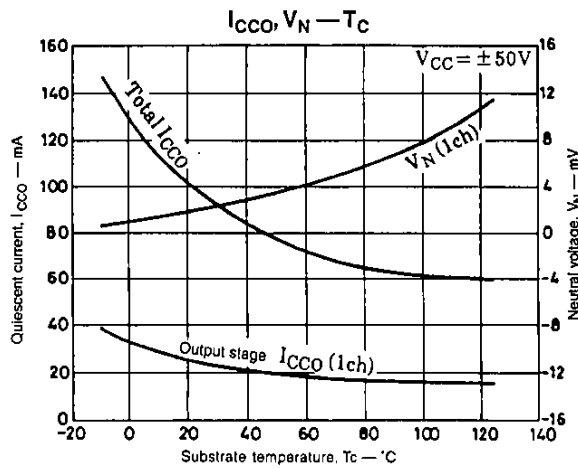
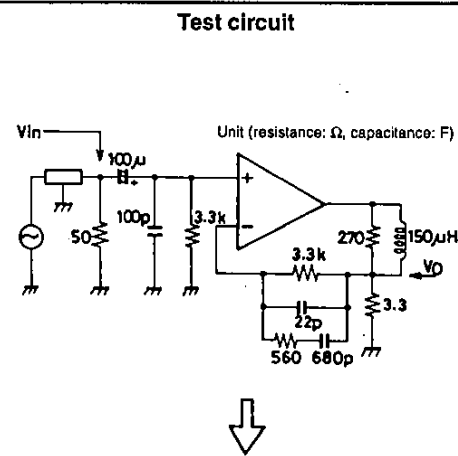
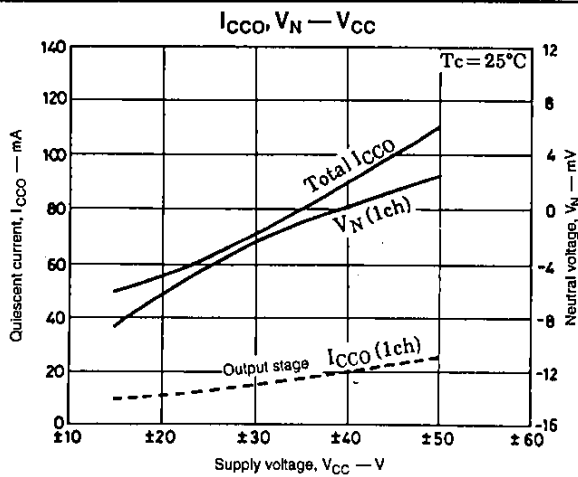

■ No products described or contained herein are intended for use in surgical implants, life-support systems, aerospace equipment, nuclear power control systems, vehicles, disaster/crime-prevention equipment and the like, the failure of which may directly or indirectly cause injury, death or property loss.

■ Anyone purchasing any products described or contained herein for an above-mentioned use shall:

- ① Accept full responsibility and indemnify and defend SANYO ELECTRIC CO., LTD., its affiliates, subsidiaries and distributors and all their officers and employees, jointly and severally, against any and all claims and litigation and all damages, cost and expenses associated with such use;
- ② Not impose any responsibility for any fault or negligence which may be cited in any such claim or litigation on SANYO ELECTRIC CO., LTD., its affiliates, subsidiaries and distributors or any of their officers and employees, jointly or severally.

■ Information (including circuit diagrams and circuit parameters) herein is for example only; it is not guaranteed for volume production. SANYO believes information herein is accurate and reliable, but no guarantees are made or implied regarding its use or any infringements of intellectual property rights or other rights of third parties.

This catalog provides information as of June, 1995. Specifications and information herein are subject to change without notice.