



STK412-020

Two-Channel Shift Power Supply Audio Power Amplifier ICs 80W + 80 W

Overview

The STK412-000 series are class H audio power amplifier hybrid ICs that feature a built-in shift power supply circuit. These ICs provide high efficiency audio power amplification by controlling (switching) the supply voltage supplied to the power transistors according to the detected level of the input audio signal.

Features

- Pin compatible IC series that covers power ratings from 50 W × 2 channels to 180 W × 2 channels at 0.7 or 0.8% THD, 20 Hz to 20 kHz. This allows the use of a common PCB for all output classes.
- The pin arrangement is also unified with that of the three-channel STK413-000 series. This means that PCBs designed for three-channel models can also be used for two-channel models.
- Miniature package
 - 50 W/ch to 120 W/ch (THD = 0.8%, f = 20 Hz to 20 kHz): 64 × 36.5 × 8.5 mm*
 - 150 W/ch to 180 W/ch (THD = 0.7%, f = 20 Hz to 20 kHz): 78 × 44 × 9 mm*
- * Not including the IC pins.
- Allowable load shorted time: 0.3 s

Package Dimensions

unit: mm

4196-SIP18

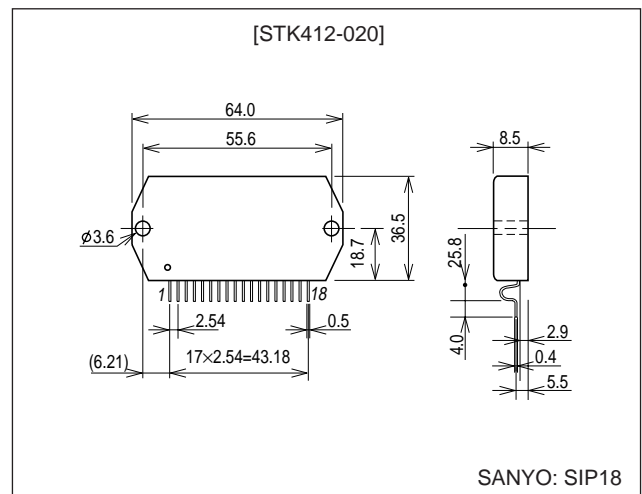

■ Any and all SANYO products described or contained herein do not have specifications that can handle applications that require extremely high levels of reliability, such as life-support systems, aircraft's control systems, or other applications whose failure can be reasonably expected to result in serious physical and/or material damage. Consult with your SANYO representative nearest you before using any SANYO products described or contained herein in such applications.

■ SANYO assumes no responsibility for equipment failures that result from using products at values that exceed, even momentarily, rated values (such as maximum ratings, operating condition ranges, or other parameters) listed in products specifications of any and all SANYO products described or contained herein.

SANYO Electric Co.,Ltd. Semiconductor Company

TOKYO OFFICE Tokyo Bldg., 1-10, 1 Chome, Ueno, Taito-ku, TOKYO, 110-8534 JAPAN

STK412-020

Series Organization

These products are organized into a series based on their output power.

Parameter	Type No.							
	STK412-090	STK412-000	STK412-010	STK412-020	STK412-030	STK412-040	STK412-150	STK412-170
Output (20 Hz to 20 kHz) [THD]	50 W + 50 W [0.8 %]	60 W + 60 W [0.8 %]	70 W + 70 W [0.8 %]	80 W + 80 W [0.8 %]	100 W + 100 W [0.8 %]	120 W + 120 W [0.8 %]	150 W + 150 W [0.7 %]	180 W + 180 W [0.7 %]
Maximum supply voltage, V_H (No signal)	±60 V	±65 V	±69 V	±73 V	±80 V	±84 V	±95 V	±95 V
Maximum supply voltage, V_L (No signal)	±41 V	±42 V	±44 V	±45 V	±46 V	±51 V	±61 V	±60 V
Recommended supply voltage, V_H	±37 V	±39 V	±43 V	±45 V	±51 V	±54 V	±57 V	±54 V
Recommended supply voltage, V_L	±27 V	±29 V	±30 V	±32 V	±34 V	±36 V	±38 V	±37 V
Recommended load impedance	8 Ω						6 Ω	4 Ω
Package	64 mm × 36.5 mm × 8.5 mm						78 mm × 44 mm × 9 mm	

Specifications

Maximum Ratings at $T_a = 25^\circ\text{C}$

Parameter	Symbol	Conditions	Ratings	Unit
V_H : Maximum supply voltage 1 (no signal)	$V_H \text{ max}(1)$		±73	V
V_H : Maximum supply voltage 2 (signal present)	$V_H \text{ max}(2)$	$R_L = 8, 6 \Omega$	±65	V
V_H : Maximum supply voltage 3 (signal present)	$V_H \text{ max}(3)$	$R_L = 4 \Omega$	±52	V
V_L : Maximum supply voltage 1 (no signal)	$V_L \text{ max}(1)$		±45	V
V_L : Maximum supply voltage 2 (signal present)	$V_L \text{ max}(2)$	$R_L = 8, 6 \Omega$	±42	V
V_L : Maximum supply voltage 3 (signal present)	$V_L \text{ max}(3)$	$R_L = 4 \Omega$	±32	V
V_H - V_L : Maximum supply voltage *4	$V_{H-L} \text{ max}$	No load	60	V
Thermal resistance	θ_{j-c}	Per power transistor	1.7	$^\circ\text{C}/\text{W}$
Junction temperature	$T_j \text{ max}$	Both the $T_{j\text{max}}$ and $T_{c\text{max}}$ conditions must be met.	150	$^\circ\text{C}$
Operating IC substrate temperature	$T_c \text{ max}$		125	$^\circ\text{C}$
Storage temperature	T_{stg}		-30 to +125	$^\circ\text{C}$
Allowable load shorted time *3	t_s	$V_H = \pm 45 \text{ V}, V_L = \pm 32 \text{ V}, R_L = 8 \Omega, f = 50 \text{ Hz}, P_O = 80 \text{ W},$ one channel operating	0.3	s

Operating Characteristics at $T_a = 25^\circ\text{C}$, $R_L = 8 \Omega$, $R_g = 600 \Omega$, $V_G = 40 \text{ dB}$, $V_Z = 15 \text{ V}$, R_L must be a non-inductive load.

Parameter	Symbol	Test conditions *1				Standard value			Unit	
		V_{CC} (V)	f (Hz)	P_O (W)	THD (%)	min	typ	max		
Output power	P_O (1)	$V_H = \pm 45$ $V_L = \pm 32$	20 to 20 k		0.8	80			W	
	P_O (2)	$V_H = \pm 36$ $V_L = \pm 26$	1 k		0.8		80		W	
Total harmonic distortion	THD	$V_H = \pm 45$ $V_L = \pm 32$	20 to 20 k	80			0.4		%	
Frequency characteristics	f_L, f_H	$V_H = \pm 45$ $V_L = \pm 32$		1.0		+0 -3 dB	20 to 50 k		Hz	
Input impedance	r_i	$V_H = \pm 45$ $V_L = \pm 32$	1 k	1.0			55		kΩ	
Output noise voltage *2	V_{NO}	$V_H = \pm 54$ $V_L = \pm 35$				$R_g = 2.2 \text{ k}\Omega$		1.0	mVrms	
Quiescent current	I_{CCO}	$V_H = \pm 54$				No load		30	mA	
		$V_L = \pm 35$				No load		100	mA	
Midpoint voltage	V_N	$V_H = \pm 54$ $V_L = \pm 35$					-70	0	+70	mV

Notes: *1. Unless otherwise specified, a constant-voltage power supply must be used during inspection.

*2. The output noise voltage rating gives the peak value read by an averaging VTVM. However, to eliminate the influence of flicker noise from the AC primary side line, use an AC stabilized power supply (50 Hz).

- *3. Use the transformer power supply specified in the figure below for allowable load shorted time and output noise voltage measurements.
- *4. Design circuits so that $(|V_H| - |V_L|)$ is always less than 40 V when switching the power supply with the load connected.
- *5. Set up the V_L power supply with an offset voltage at power supply switching ($V_L - L_O$) of about 8 V as an initial target.

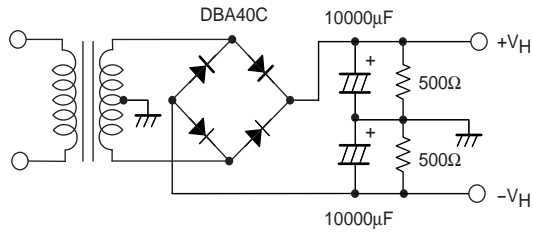

**Specified Transformer Power Supply
(MG-250 equivalent)**

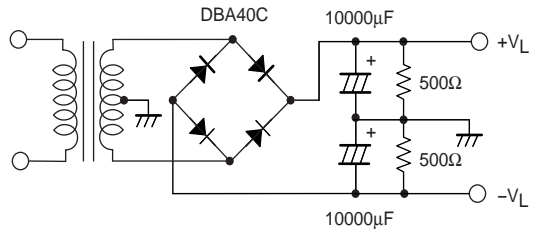

**Specified Transformer Power Supply
(MG-200 equivalent)**

Internal Equivalent Circuit

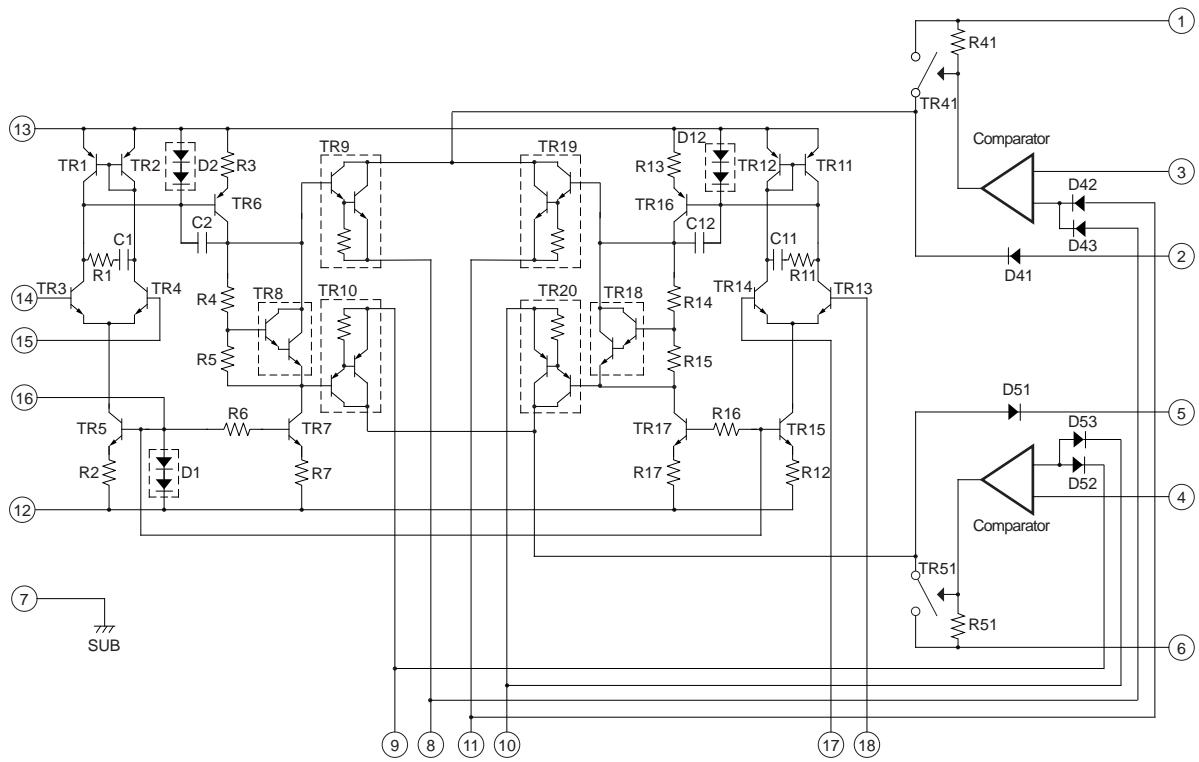

Sample Application Circuit

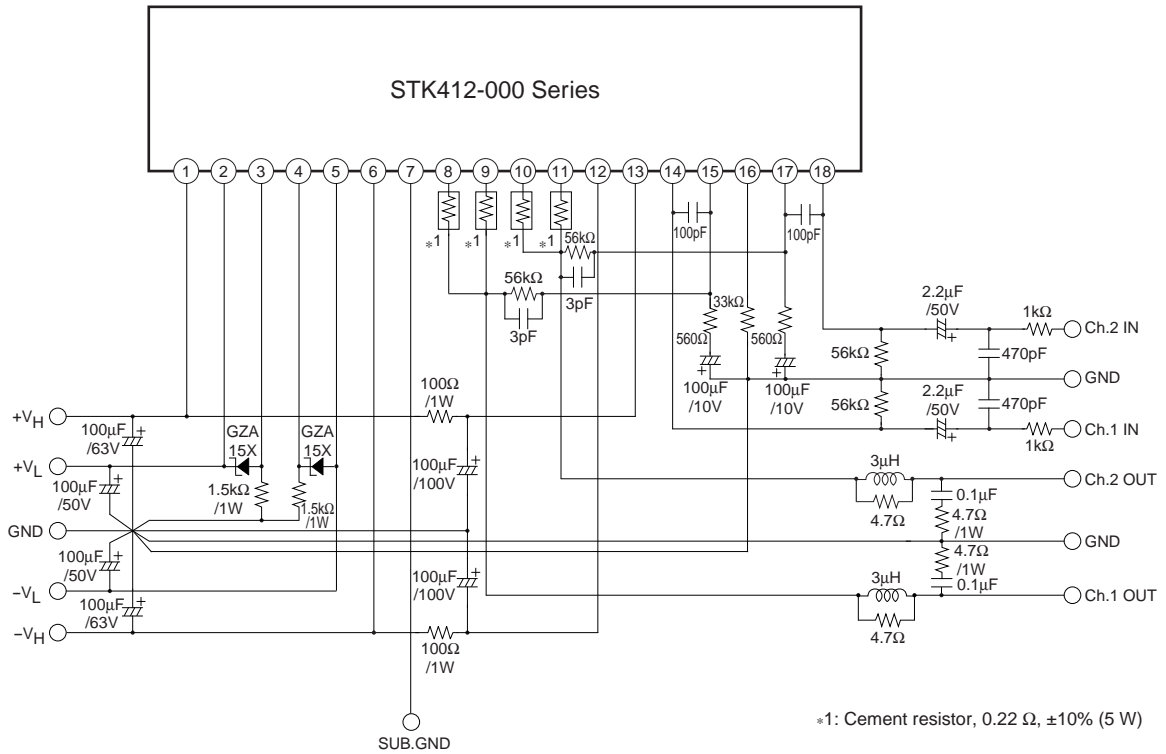

- Specifications of any and all SANYO products described or contained herein stipulate the performance, characteristics, and functions of the described products in the independent state, and are not guarantees of the performance, characteristics, and functions of the described products as mounted in the customer's products or equipment. To verify symptoms and states that cannot be evaluated in an independent device, the customer should always evaluate and test devices mounted in the customer's products or equipment.
- SANYO Electric Co., Ltd. strives to supply high-quality high-reliability products. However, any and all semiconductor products fail with some probability. It is possible that these probabilistic failures could give rise to accidents or events that could endanger human lives, that could give rise to smoke or fire, or that could cause damage to other property. When designing equipment, adopt safety measures so that these kinds of accidents or events cannot occur. Such measures include but are not limited to protective circuits and error prevention circuits for safe design, redundant design, and structural design.
- In the event that any or all SANYO products (including technical data, services) described or contained herein are controlled under any of applicable local export control laws and regulations, such products must not be exported without obtaining the export license from the authorities concerned in accordance with the above law.
- No part of this publication may be reproduced or transmitted in any form or by any means, electronic or mechanical, including photocopying and recording, or any information storage or retrieval system, or otherwise, without the prior written permission of SANYO Electric Co., Ltd.
- Any and all information described or contained herein are subject to change without notice due to product/technology improvement, etc. When designing equipment, refer to the "Delivery Specification" for the SANYO product that you intend to use.
- Information (including circuit diagrams and circuit parameters) herein is for example only; it is not guaranteed for volume production. SANYO believes information herein is accurate and reliable, but no guarantees are made or implied regarding its use or any infringements of intellectual property rights or other rights of third parties.

This catalog provides information as of February, 2003. Specifications and information herein are subject to change without notice.