

STK412-040**Two-Channel Shift Power Supply Audio Power Amplifier ICs
120W + 120 W****Overview**

The STK412-000 series are class H audio power amplifier hybrid ICs that feature a built-in shift power supply circuit. These ICs provide high efficiency audio power amplification by controlling (switching) the supply voltage supplied to the power transistors according to the detected level of the input audio signal.

Features

- Pin compatible IC series that covers power ratings from 50 W × 2 channels to 180 W × 2 channels at 0.7 or 0.8% THD, 20 Hz to 20 kHz. This allows the use of a common PCB for all output classes.
- The pin arrangement is also unified with that of the three-channel STK413-000 series. This means that PCBs designed for three-channel models can also be used for two-channel models.
- Miniature package
 - 50 W/ch to 120 W/ch (THD = 0.8%, f = 20 Hz to 20 kHz): 64 × 36.5 × 8.5 mm*
 - 150 W/ch to 180 W/ch (THD = 0.7%, f = 20 Hz to 20 kHz): 78 × 44 × 9 mm*
- * Not including the IC pins.
- Allowable load shorted time: 0.3 s

Package Dimensions

unit: mm

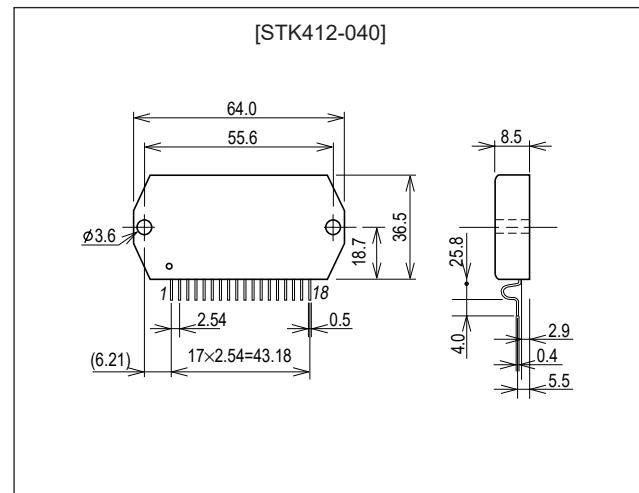
4196-SIP18

STK412-040

Series Organization

These products are organized into a series based on their output power.

Parameter	Type No.							
	STK412-090	STK412-000	STK412-010	STK412-020	STK412-030	STK412-040	STK412-150	STK412-170
Output (20 Hz to 20 kHz) [THD]	50 W + 50 W [0.8 %]	60 W + 60 W [0.8 %]	70 W + 70 W [0.8 %]	80 W + 80 W [0.8 %]	100 W + 100 W [0.8 %]	120 W + 120 W [0.8 %]	150 W + 150 W [0.7 %]	180 W + 180 W [0.7 %]
Maximum supply voltage, V_H (No signal)	±60 V	±65 V	±69 V	±73 V	±80 V	±84 V	±95 V	±95 V
Maximum supply voltage, V_L (No signal)	±41 V	±42 V	±44 V	±45 V	±46 V	±51 V	±61 V	±60 V
Recommended supply voltage, V_H	±37 V	±39 V	±43 V	±45 V	±51 V	±54 V	±57 V	±54 V
Recommended supply voltage, V_L	±27 V	±29 V	±30 V	±32 V	±34 V	±36 V	±38 V	±37 V
Recommended load impedance	8 Ω						6 Ω	4 Ω
Package	64 mm × 36.5 mm × 8.5 mm						78 mm × 44 mm × 9 mm	

Specifications

Maximum Ratings at $T_a = 25^\circ\text{C}$

Parameter	Symbol	Conditions	Ratings	Unit
V_H : Maximum supply voltage 1 (no signal)	$V_H \text{ max}(1)$		±84	V
V_H : Maximum supply voltage 2 (signal present)	$V_H \text{ max}(2)$	$R_L = 8, 6 \Omega$	±78	V
V_H : Maximum supply voltage 3 (signal present)	$V_H \text{ max}(3)$	$R_L = 4 \Omega$	±60	V
V_L : Maximum supply voltage 1 (no signal)	$V_L \text{ max}(1)$		±51	V
V_L : Maximum supply voltage 2 (signal present)	$V_L \text{ max}(2)$	$R_L = 8, 6 \Omega$	±48	V
V_L : Maximum supply voltage 3 (signal present)	$V_L \text{ max}(3)$	$R_L = 4 \Omega$	±36	V
V_H - V_L : Maximum supply voltage *4	$V_{H-L} \text{ max}$	No load	60	V
Thermal resistance	θ_{j-c}	Per power transistor	1.6	$^\circ\text{C}/\text{W}$
Junction temperature	$T_j \text{ max}$	Both the $T_{j\text{max}}$ and $T_{c\text{max}}$ conditions must be met.	150	$^\circ\text{C}$
Operating IC substrate temperature	$T_c \text{ max}$		125	$^\circ\text{C}$
Storage temperature	T_{stg}		-30 to +125	$^\circ\text{C}$
Allowable load shorted time *3	t_s	$V_H = \pm 54 \text{ V}, V_L = \pm 36 \text{ V}, R_L = 8 \Omega, f = 50 \text{ Hz}, P_O = 120 \text{ W},$ one channel operating	0.3	s

Operating Characteristics at $T_a = 25^\circ\text{C}, R_L = 8 \Omega, R_g = 600 \Omega, V_G = 40 \text{ dB}, V_Z = 15 \text{ V}, R_L$ must be a non-inductive load.

Parameter	Symbol	Test conditions *1					Standard value			Unit
		V_{CC} (V)	f (Hz)	P_O (W)	THD (%)		min	typ	max	
Output power	P_O (1)	$V_H = \pm 54$ $V_L = \pm 36$	20 to 20 k		0.8		120			W
	P_O (2)	$V_H = \pm 43$ $V_L = \pm 29$	1 k		0.8	$R_L = 4 \Omega$		120		W
Total harmonic distortion	THD	$V_H = \pm 54$ $V_L = \pm 36$	20 to 20 k	120				0.4		%
Frequency characteristics	f_L, f_H	$V_H = \pm 54$ $V_L = \pm 36$		1.0		+0 -3 dB	20 to 50 k			Hz
Input impedance	r_i	$V_H = \pm 54$ $V_L = \pm 36$	1 k	1.0				55		kΩ
Output noise voltage *2	V_{NO}	$V_H = \pm 65$ $V_L = \pm 40$				$R_g = 2.2 \text{ k}\Omega$			1.0	mVrms
Quiescent current	I_{CCO}	$V_H = \pm 65$				No load			30	mA
		$V_L = \pm 40$				No load			100	mA
Midpoint voltage	V_N	$V_H = \pm 65$ $V_L = \pm 40$					-70	0	+70	mV

Notes: *1. Unless otherwise specified, a constant-voltage power supply must be used during inspection.

*2. The output noise voltage rating gives the peak value read by an averaging VTVM. However, to eliminate the influence of flicker noise from the AC primary side line, use an AC stabilized power supply (50 Hz).

STK412-040

- *3. Use the transformer power supply specified in the figure below for allowable load shorted time and output noise voltage measurements.
- *4. Design circuits so that $(|V_H| - |V_L|)$ is always less than 40 V when switching the power supply with the load connected.
- *5. Set up the V_L power supply with an offset voltage at power supply switching ($V_L - L_O$) of about 8 V as an initial target.

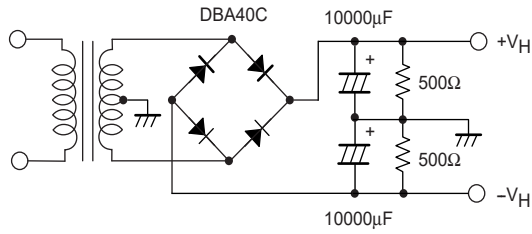

**Specified Transformer Power Supply
(MG-250 equivalent)**

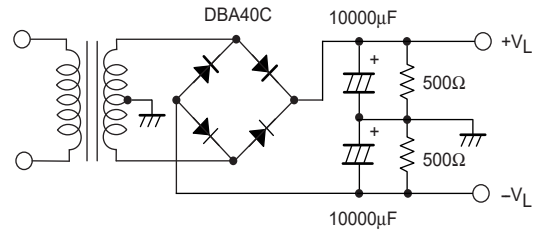

**Specified Transformer Power Supply
(MG-200 equivalent)**

Internal Equivalent Circuit

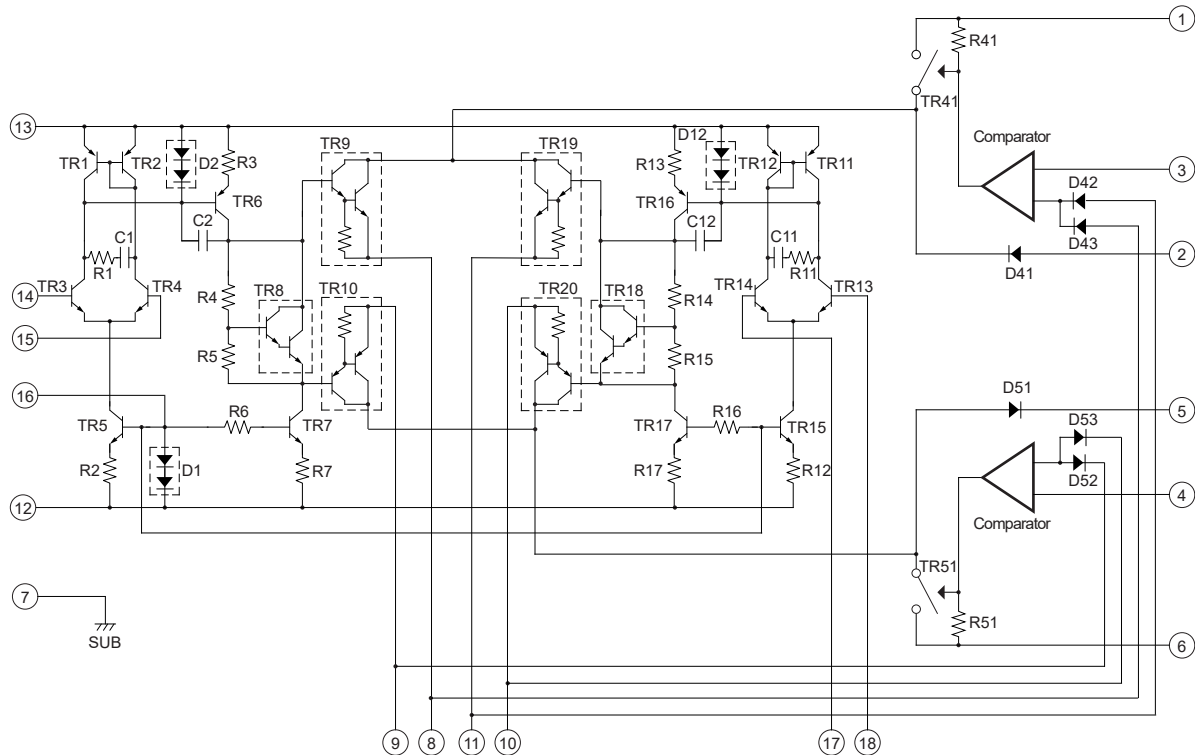

STK412-040

Sample Application Circuit

