

TOSHIBA BIPOLAR DIGITAL INTEGRATED CIRCUIT SILICON MONOLITHIC

TD62081AP, TD62081CP, TD62081F, TD62081AF, TD62082AP, TD62082CP
TD62082F, TD62082AF, TD62083AP, TD62083CP, TD62083F, TD62083AF
TD62084AP, TD62084CP, TD62084F, TD62084AF

8CH DARLINGTON SINK DRIVER

The TD62081AP/CP/F/AF Series are high-voltage, high-current darlington drivers comprised of eight NPN darlington pairs.

All units feature integral clamp diodes for switching inductive loads.

Applications include relay, hammer, lamp and display (LED) drivers.

FEATURES

- Output current (single output)
 500mA (Max.) (TD62081AP/F/AF series)
 400mA (Max.) (TD62081CP series)
- High sustaining voltage output
 35V (Min.) (TD62081F series)
 50V (Min.) (TD62081AP/AF series)
 100V (Min.) (TD62081CP series)
- Output clamp diodes
- Inputs compatible with various types of logic.
- Package type-AP, CP : DIP-18pin
- Package type-F, AF : SOP-18pin

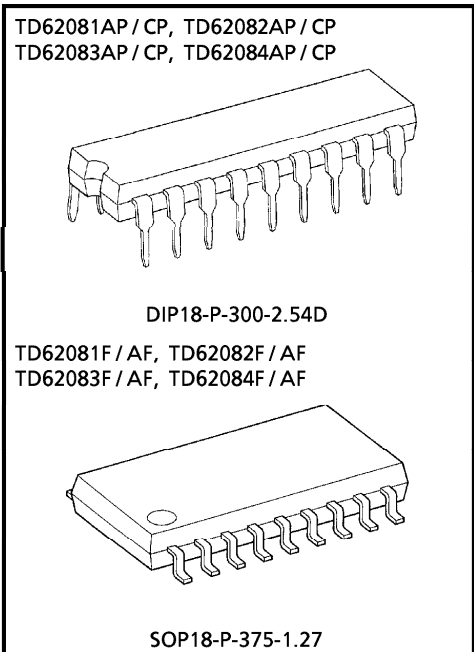

Weight
 DIP18-P-300-2.54D : 1.478g (Typ.)
 SOP18-P-375-1.27 : 0.41g (Typ.)

| TYPE | INPUT BASE RESISTOR | DESIGNATION |
|-------------------|-----------------------------|------------------|
| TD62081AP/CP/F/AF | External | General Purpose |
| TD62082AP/CP/F/AF | 10.5-kΩ + 7V Zener diode | 14~25V PMOS |
| TD62083AP/CP/F/AF | 2.7kΩ | TTL, 5V CMOS |
| TD62084AP/CP/F/AF | 10.5kΩ | 6~15V PMOS, CMOS |

PIN CONNECTION (TOP VIEW)

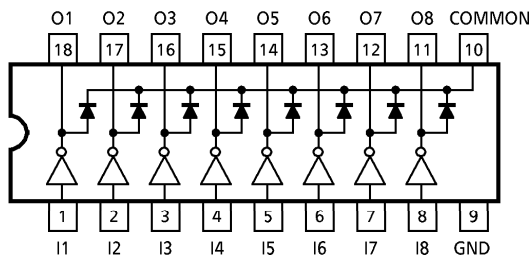

SCHEMATICS (EACH DRIVER)

TD62081AP / CP / F / AF

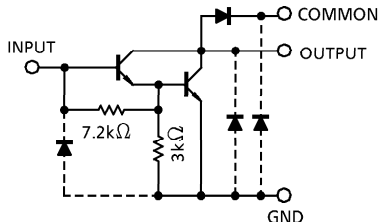

TD62082AP / CP / F / AF

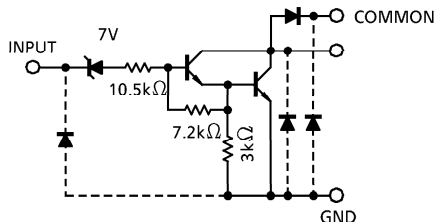

TD62083AP / CP / F / AF

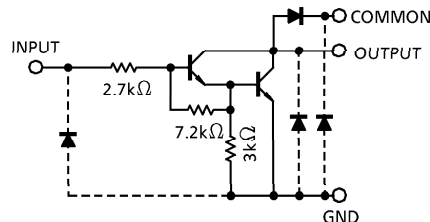

TD62084AP / CP / F / AF

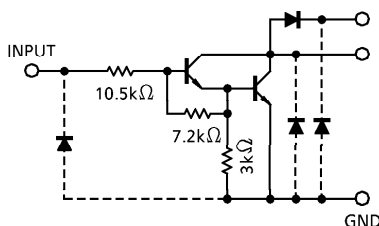

(Note) The input and output parasitic diodes cannot be used as clamp diodes.

MAXIMUM RATINGS (Ta = 25°C)

| CHARACTERISTIC | SYMBOL | RATING | UNIT |
|-----------------------------|--------------------------|-----------|---------|
| Output Sustaining Voltage | V _{CE (SUS)} | - 0.5~50 | V |
| | | - 0.5~100 | |
| | | - 0.5~35 | |
| Output Current | I _{OUT} | 500 | mA / ch |
| | | 400 | |
| Input Voltage | V _{IN} (Note 1) | - 0.5~30 | V |
| Input Current | I _{IN} (Note 2) | 25 | mA |
| Clamp Diode Reverse Voltage | V _R | 50 | V |
| | | 100 | |
| | | 35 | |
| Clamp Diode Forward Current | I _F | 500 | mA |
| | | 400 | |
| Power Dissipation | P _D | 1.47 | W |
| | | 0.96 | |
| Operating Temperature | T _{opr} | - 40~85 | °C |
| Storage Temperature | T _{stg} | - 55~150 | °C |

(Note 1) Except TD62081AP/CP/F/AF

(Note 2) Only TD62081AP/CP/F/AF

RECOMMENDED OPERATING CONDITIONS (Ta = -40~85°C)

| CHARACTERISTIC | | SYMBOL | TEST CONDITION | MIN. | TYP. | MAX. | UNIT |
|-----------------------------|--------------------------------|-----------------------|---|------|------|------|---------|
| Output Sustaining Voltage | AP, AF | V _{CE (SUS)} | | 0 | — | 50 | V |
| | CP | | | 0 | — | 100 | |
| | F | | | 0 | — | 35 | |
| Output Current | AP, CP | I _{OUT} | T _{pw} = 25ms, Duty = 10%, 8 Circuits | 0 | — | 347 | mA / ch |
| | | | T _{pw} = 25ms, Duty = 50%, 8 Circuits | 0 | — | 123 | |
| | F, AF | | T _{pw} = 25ms, Duty = 10%, 8 Circuits | 0 | — | 268 | |
| | | | T _{pw} = 25ms, Duty = 50%, 8 Circuits | 0 | — | 90 | |
| Input Voltage | Except TD62081AP / CP / F / AF | V _{IN} | | 0 | — | 30 | V |
| Input Voltage (Output On) | TD62082AP / CP / F / AF | V _{IN (ON)} | | 14 | — | 30 | V |
| | TD62083AP / CP / F / AF | | | 3.5 | — | 30 | |
| | TD62084AP / CP / F / AF | | | 8 | — | 30 | |
| Input Current | Only TD62081AP / CP / F / AF | I _{IN} | | 0 | — | 5 | mA |
| Clamp Diode Reverse Voltage | AP, AF | V _R | | — | — | 50 | V |
| | CP | | | — | — | 100 | |
| | F | | | — | — | 35 | |
| Clamp Diode Forward Current | CP | I _F | | — | — | 400 | mA |
| | | | | — | — | 320 | |
| Power Dissipation | AP, CP | P _D | | — | — | 0.52 | W |
| | F, AF | | | — | — | 0.4 | |

ELECTRICAL CHARACTERISTICS (Ta = 25°C)

| CHARACTERISTIC | | SYMBOL | TEST CIRCUIT | TEST CONDITION | MIN. | TYP. | MAX. | UNIT | |
|--------------------------------------|--|-----------------------|-----------------------|---|-------------------------------------|----------------------|------|------|-----|
| Output Leakage Current | AP, AF CP F | I _{CEX} | 1 | V _{CE} = 50V | Ta = 25°C | — | — | 50 | |
| | | | | V _{CE} = 100V | | | | | |
| | | | | V _{CE} = 35V | | | | | |
| | AP, AF CP F | | | TD62082 | V _{CE} = 50V | Ta = 85°C | — | — | 100 |
| | | | | | V _{CE} = 100V | | | | |
| | | | | | V _{CE} = 35V | | | | |
| | AP, AF CP F | | | TD62084 | V _{CE} = 50V | V _{IN} = 6V | — | — | 500 |
| | | | | | V _{CE} = 100V | | | | |
| | | | | | V _{CE} = 35V | | | | |
| | AP, AF CP F | | | TD62084 | V _{CE} = 50V | V _{IN} = 1V | — | — | 500 |
| | | | | | V _{CE} = 100V | | | | |
| | | | | | V _{CE} = 35V | | | | |
| Collector-Emitter Saturation Voltage | | V _{CE} (sat) | 2 | I _{OUT} = 350mA, I _{IN} = 500μA | — | 1.3 | 1.6 | V | |
| | | | | I _{OUT} = 200mA, I _{IN} = 350μA | — | 1.1 | 1.3 | | |
| | | | | I _{OUT} = 100mA, I _{IN} = 250μA | — | 0.9 | 1.1 | | |
| Input Current | TD62082AP / CP / F / AF | I _{IN} (ON) | 2 | V _{IN} = 17V | — | 0.82 | 1.25 | mA | |
| | TD62083AP / CP / F / AF | | | V _{IN} = 3.85V | — | 0.93 | 1.35 | | |
| | TD62084AP / CP / F / AF | | | V _{IN} = 5V | — | 0.35 | 0.5 | | |
| | | | | V _{IN} = 12V | — | 1.0 | 1.45 | | |
| | | | I _{IN} (OFF) | 4 | I _{OUT} = 500μA, Ta = 85°C | 50 | 65 | — | μA |
| Input Voltage (Output On) | TD62082AP / CP / F / AF | V _{IN} (ON) | 5 | V _{CE} = 2V, I _{OUT} = 300mA | — | — | 13 | V | |
| | | | | V _{CE} = 2V, I _{OUT} = 200mA | — | — | 2.4 | | |
| | V _{CE} = 2V, I _{OUT} = 250mA | | | — | — | 2.7 | | | |
| | V _{CE} = 2V, I _{OUT} = 300mA | | | — | — | 3.0 | | | |
| | V _{CE} = 2V, I _{OUT} = 125mA | | | — | — | 5.0 | | | |
| | V _{CE} = 2V, I _{OUT} = 200mA | | | — | — | 6.0 | | | |
| | V _{CE} = 2V, I _{OUT} = 275mA | | | — | — | 7.0 | | | |
| | V _{CE} = 2V, I _{OUT} = 350mA | | | — | — | 8.0 | | | |
| DC Current Transfer Ratio | | h _{FE} | 2 | V _{CE} = 2V, I _{OUT} = 350mA | 1000 | — | — | | |
| Clamp Diode Reverse Current | | I _R | 6 | Ta = 25°C (Note) | — | — | 50 | μA | |
| | | | | Ta = 85°C (Note) | — | — | 100 | | |
| Clamp Diode Forward Voltage | CP | V _F | 7 | I _F = 350mA | — | — | 2.0 | V | |
| | | | | I _F = 280mA | — | — | 1.8 | | |
| Input Capacitance | | C _{IN} | — | | — | 15 | — | pF | |

(Note) V_R = V_R MAX.

| CHARACTERISTIC | | SYMBOL | TEST CIRCUIT | TEST CONDITION | MIN. | TYP. | MAX. | UNIT |
|----------------|--------|-----------|--------------|-----------------------------------|------|------|------|---------|
| Turn-On Delay | AP, AF | t_{ON} | 8 | $R_L = 125\Omega, V_{OUT} = 50V$ | — | 0.1 | — | μs |
| | CP | | | $R_L = 312\Omega, V_{OUT} = 100V$ | — | 0.1 | — | |
| | F | | | $R_L = 87.5\Omega, V_{OUT} = 35V$ | — | 0.1 | — | |
| Turn-Off Delay | AP, AF | t_{OFF} | | $R_L = 125\Omega, V_{OUT} = 50V$ | — | 0.2 | — | |
| | CP | | | $R_L = 312\Omega, V_{OUT} = 100V$ | — | 3.0 | — | |
| | F | | | $R_L = 87.5\Omega, V_{OUT} = 35V$ | — | 0.2 | — | |

TEST CIRCUIT

1. I_{CEX}

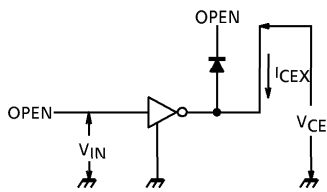

2. $V_{CE(sat)}, h_{FE}$

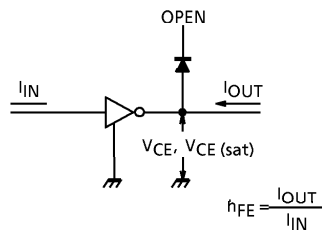

3. $I_{IN(ON)}$

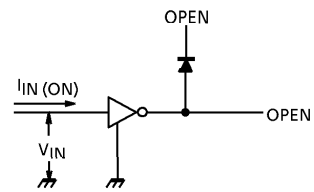

4. $I_{IN(OFF)}$

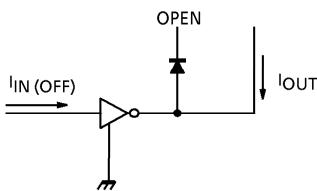

5. $V_{IN(ON)}$

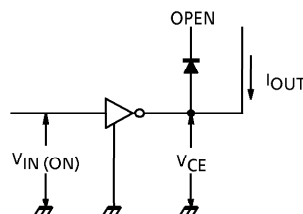

6. I_R

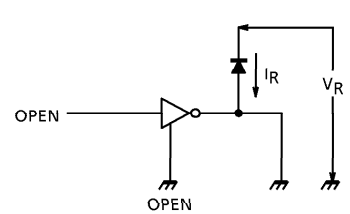

7. V_F

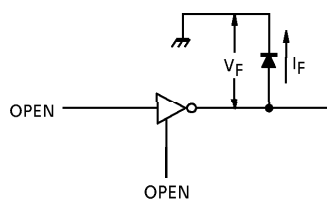

8. t_{ON} , t_{OFF}

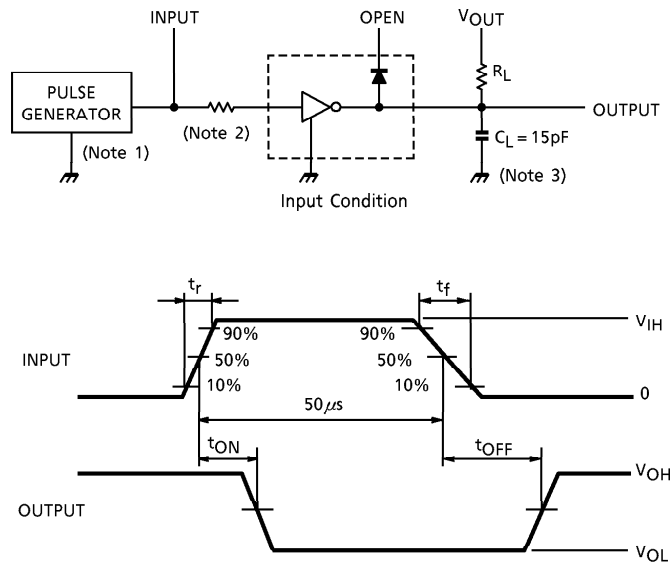

- (Note 1) Pulse Width $50\mu s$, Duty Cycle 10%
Output Impedance 50Ω , $t_r \leq 5ns$, $t_f \leq 10ns$
- (Note 2) See below.

INPUT CONDITION

| TYPE NUMBER | R1 | V_{IH} |
|-------------------|--------------|----------|
| TD62081AP/CP/F/AF | $2.7k\Omega$ | 3V |
| TD62082AP/CP/F/AF | 0Ω | 13V |
| TD62083AP/CP/F/AF | 0Ω | 3V |
| TD62084AP/CP/F/AF | 0Ω | 8V |

- (Note 3) C_L includes probe and jig capacitance

PRECAUTIONS for USING

Utmost care is necessary in the design of the output line, COMMON and GND line since IC may be destroyed due to short-circuit between outputs, air contamination fault, or fault by improper grounding.

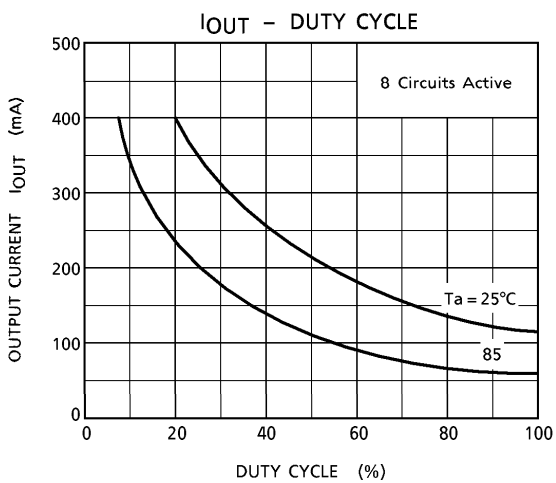
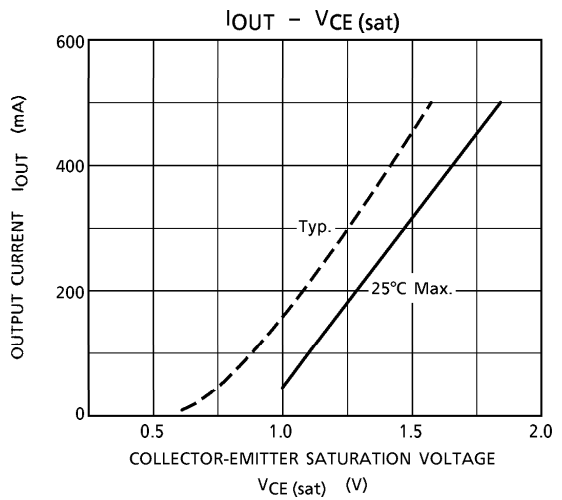
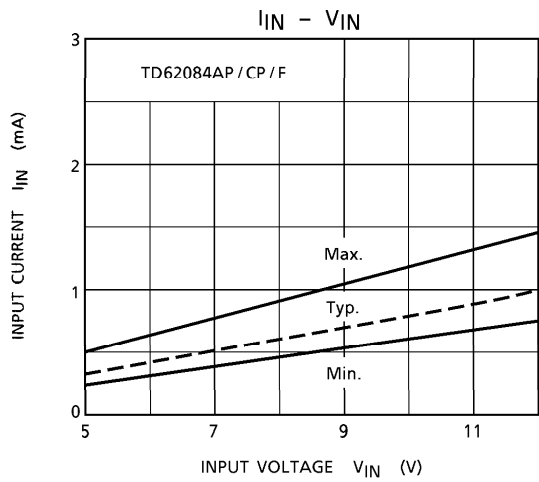
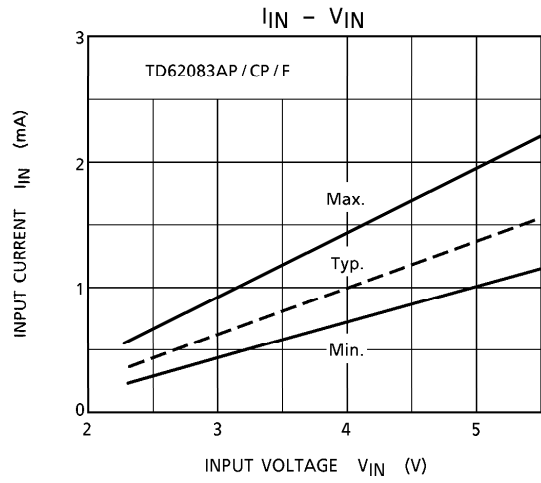
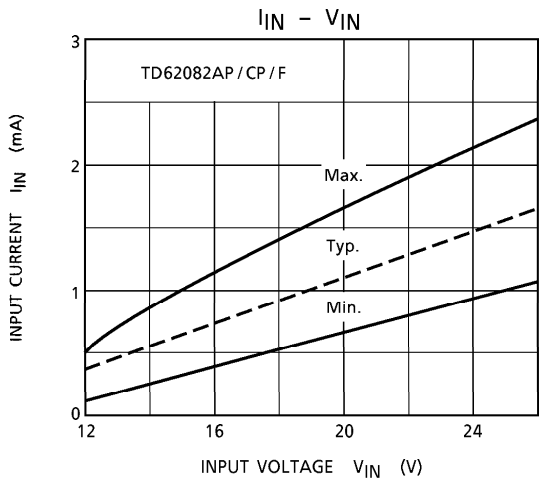

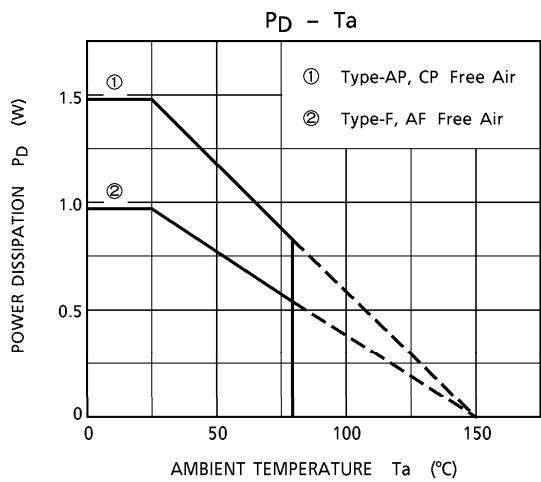
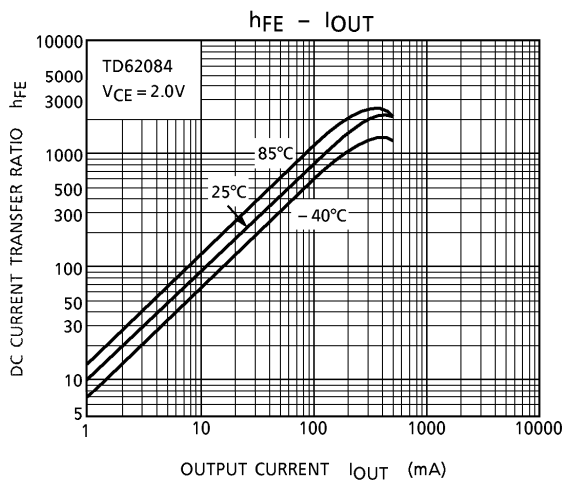
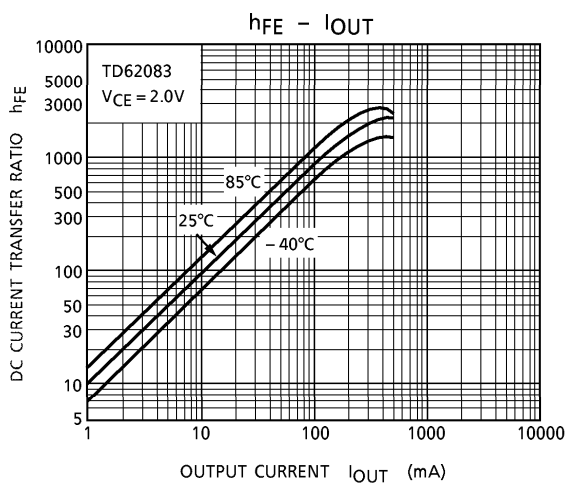

OUTLINE DRAWING
DIP18-P-300-2.54D

Unit : mm

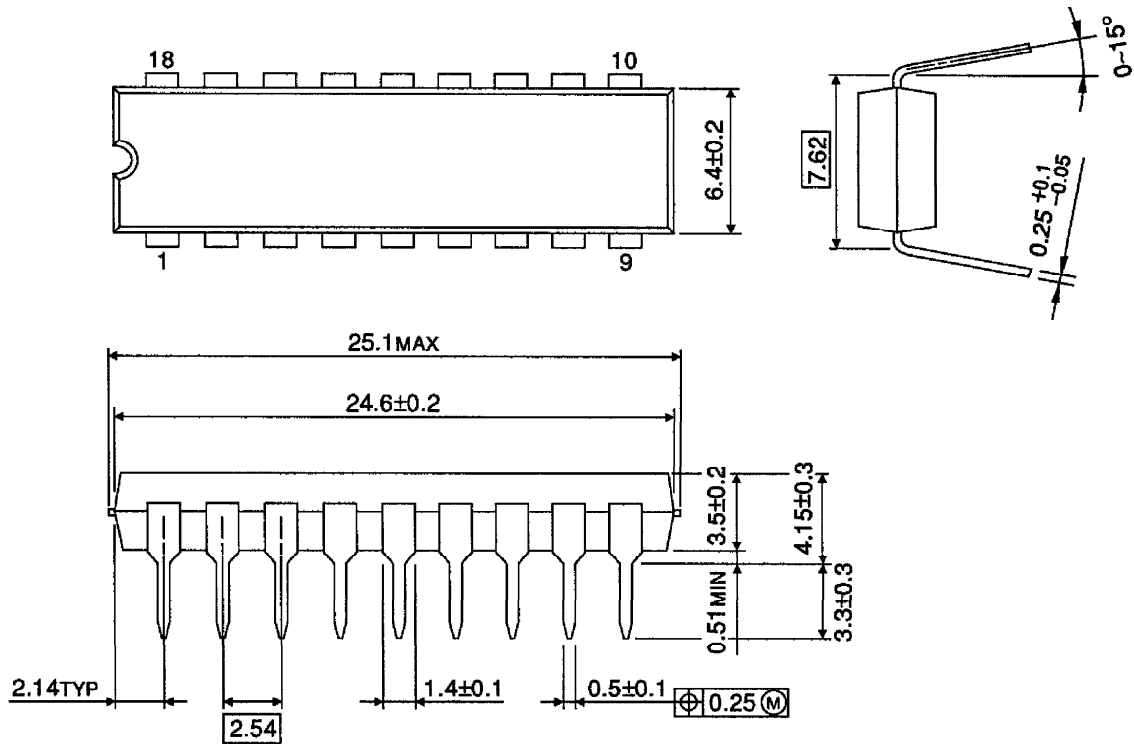

Weight : 1.478g (Typ.)

OUTLINE DRAWING
SOP18-P-375-1.27

Unit : mm

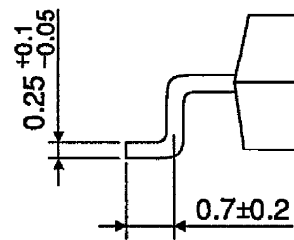
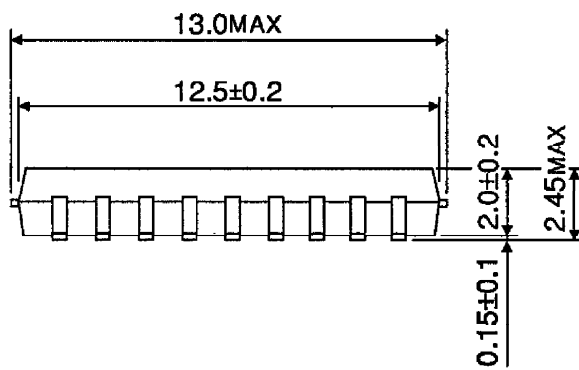
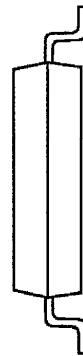
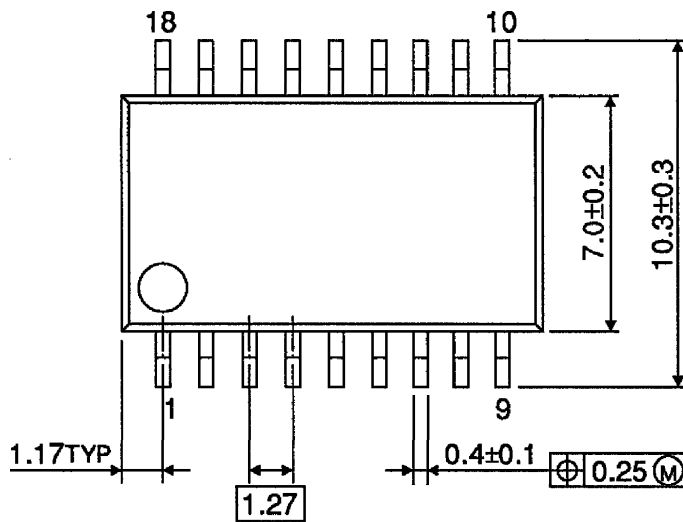

Weight : 0.41g (Typ.)