

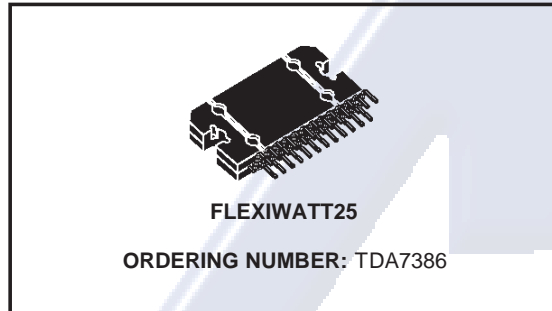

TDA7386

4 x 40W QUAD BRIDGE CAR RADIO AMPLIFIER

- HIGH OUTPUT POWER CAPABILITY:
 - 4 x 45W/4Ω MAX.
 - 4 x 40W/4Ω EIAJ
 - 4 x 28W/4Ω @ 14.4V, 1KHz, 10%
 - 4 x 24W/4Ω @ 13.2V, 1KHz, 10%
- LOW DISTORTION
- LOW OUTPUT NOISE
- ST-BY FUNCTION
- MUTE FUNCTION
- AUTOMUTE AT MIN. SUPPLY VOLTAGE DETECTION
- LOW EXTERNAL COMPONENT COUNT:
 - INTERNALLY FIXED GAIN (26dB)
 - NO EXTERNAL COMPENSATION
 - NO BOOTSTRAP CAPACITORS



- REVERSED BATTERY
- ESD

DESCRIPTION

The TDA7386 is a new technology class AB Audio Power Amplifier in Flexiwatt 25 package designed for high end car radio applications.

Thanks to the fully complementary PNP/NPN output configuration the TDA7386 allows a rail to rail output voltage swing with no need of bootstrap capacitors. The extremely reduced components count allows very compact sets.

PROTECTIONS:

- OUTPUT SHORT CIRCUIT TO GND, TO Vs, ACROSS THE LOAD
- VERY INDUCTIVE LOADS
- OVERRATING CHIP TEMPERATURE WITH SOFT THERMAL LIMITER
- LOAD DUMP VOLTAGE
- FORTUITOUS OPEN GND

BLOCK AND APPLICATION DIAGRAM

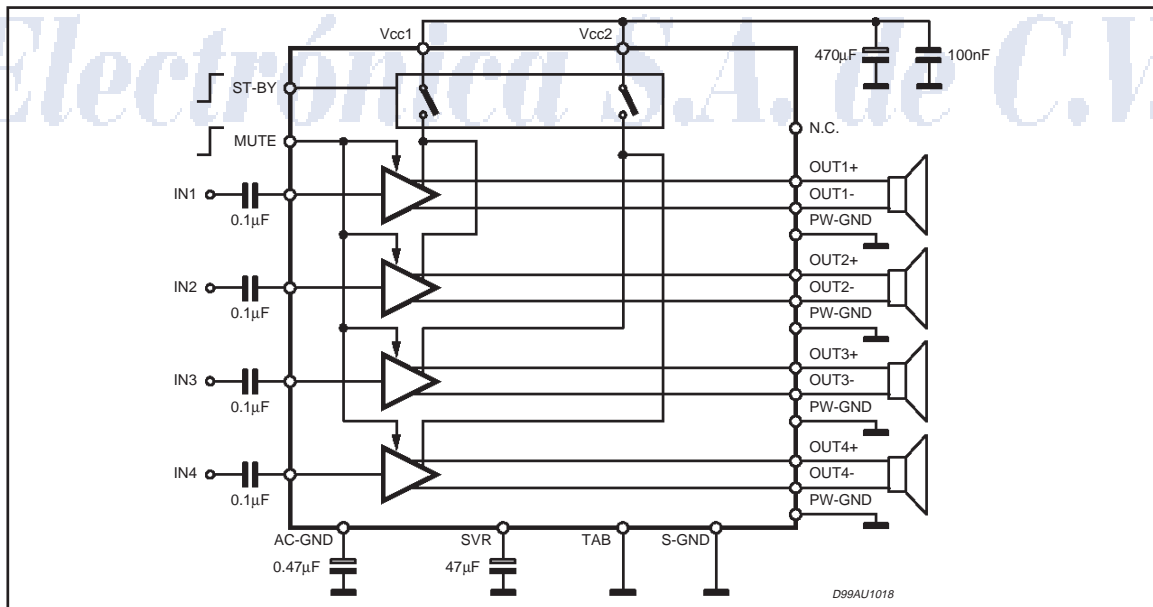

TDA7386

ABSOLUTE MAXIMUM RATINGS

Symbol	Parameter	Value	Unit
V_{CC}	Operating Supply Voltage	18	V
$V_{CC(DC)}$	DC Supply Voltage	28	V
$V_{CC(pk)}$	Peak Supply Voltage (t = 50ms)	50	V
I_o	Output Peak Current: Repetitive (Duty Cycle 10% at f = 10Hz)	4.5	A
	Non Repetitive (t = 100 μ s)	5.5	A
P_{tot}	Power dissipation, (T _{case} = 70°C)	80	W
T_j	Junction Temperature	150	°C
T_{stg}	Storage Temperature	- 55 to 150	°C

PIN CONNECTION (Top view)

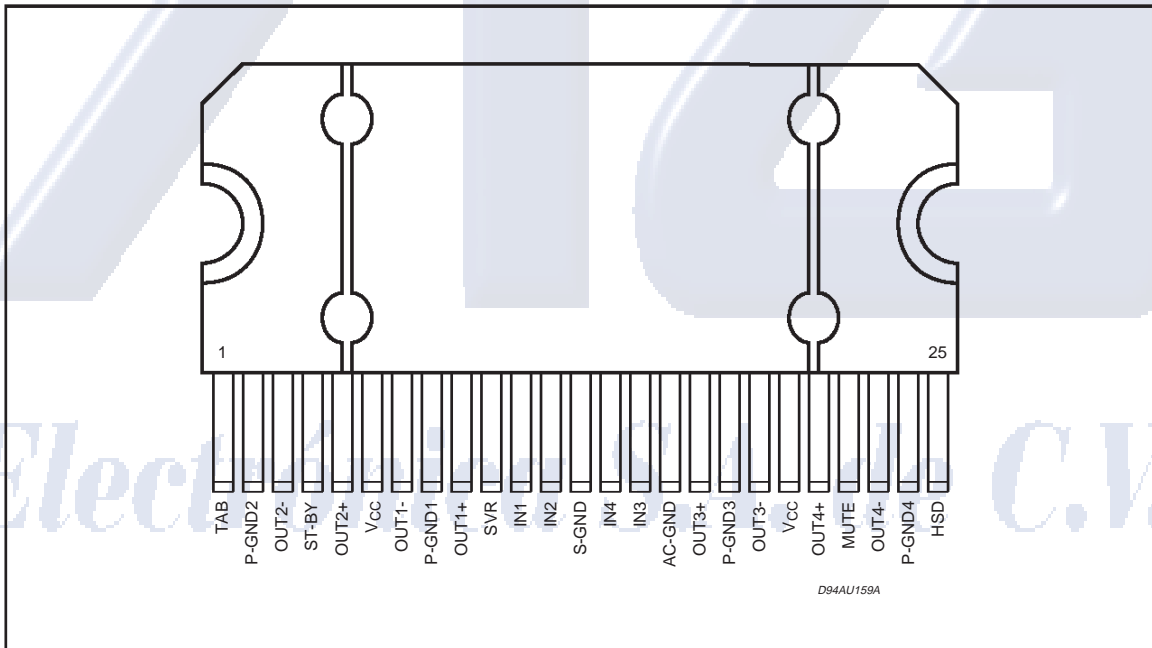

THERMAL DATA

Symbol	Parameter	Value	Unit
$R_{th\ j-case}$	Thermal Resistance Junction to Case	Max. 1	°C/W

TDA7386

ELECTRICAL CHARACTERISTICS ($V_S = 14.4V$; $f = 1KHz$; $R_g = 600\Omega$; $R_L = 4\Omega$; $T_{amb} = 25^\circ C$;
Refer to the test and application diagram, unless otherwise specified.)

Symbol	Parameter	Test Condition	Min.	Typ.	Max.	Unit
I_{q1}	Quiescent Current	$R_L = \infty$		190	350	mA
V_{OS}	Output Offset Voltage	Play Mode			± 80	mV
dV_{OS}	During mute ON/OFF output offset voltage				± 80	mV
G_v	Voltage Gain		25	26	27	dB
dG_v	Channel Gain Unbalance				± 1	dB
P_o	Output Power	$V_S = 13.2V$; THD = 10% $V_S = 13.2V$; THD = 0.8% $V_S = 14.4V$; THD = 10%	22 16.5 26	24 18 28		W W W
$P_{o\ EIAJ}$	EIAJ Output Power (*)	$V_S = 13.7V$	37.5	40		W
$P_{o\ max.}$	Max. Output Power (*)	$V_S = 14.4V$	43	45		W
THD	Distortion	$P_o = 4W$		0.04	0.15	%
e_{No}	Output Noise	"A" Weighted Bw = 20Hz to 20KHz		50 70	70 100	μV μV
SVR	Supply Voltage Rejection	$f = 100Hz$; $V_r = 1V_{rms}$	50	75		dB
f_{ch}	High Cut-Off Frequency	$P_o = 0.5W$	80	200		KHz
R_i	Input Impedance		70	100		K Ω
C_T	Cross Talk	$f = 1KHz$ $P_o = 4W$ $f = 10KHz$ $P_o = 4W$	60	70 60	- -	dB dB
I_{SB}	St-By Current Consumption	$V_{St-By} = 1.5V$			100	μA
I_{pin4}	St-by pin Current	$V_{St-By} = 1.5V$ to $3.5V$			± 10	μA
$V_{SB\ out}$	St-By Out Threshold Voltage	(Amp: ON)	3.5			V
$V_{SB\ in}$	St-By in Threshold Voltage	(Amp: OFF)			1.5	V
A_M	Mute Attenuation	$P_{Oref} = 4W$	80	90		dB
$V_{M\ out}$	Mute Out Threshold Voltage	(Amp: Play)	3.5			V
$V_{M\ in}$	Mute In Threshold Voltage	(Amp: Mute)			1.5	V
$V_{AM\ in}$	V_S Automute Threshold	(Amp: Mute) Att $\geq 80dB$; $P_{Oref} = 4W$ (Amp: Play) Att $< 0.1dB$; $P_o = 0.5W$			6.5	V
I_{pin22}	Muting Pin Current	$V_{MUTE} = 1.5V$ (Sourced Current)	5	11	20	μA
		$V_{MUTE} = 3.5V$	-5		20	μA

(*) Saturated square wave output.

TDA7386

Figure 1: Standard Test and Application Circuit

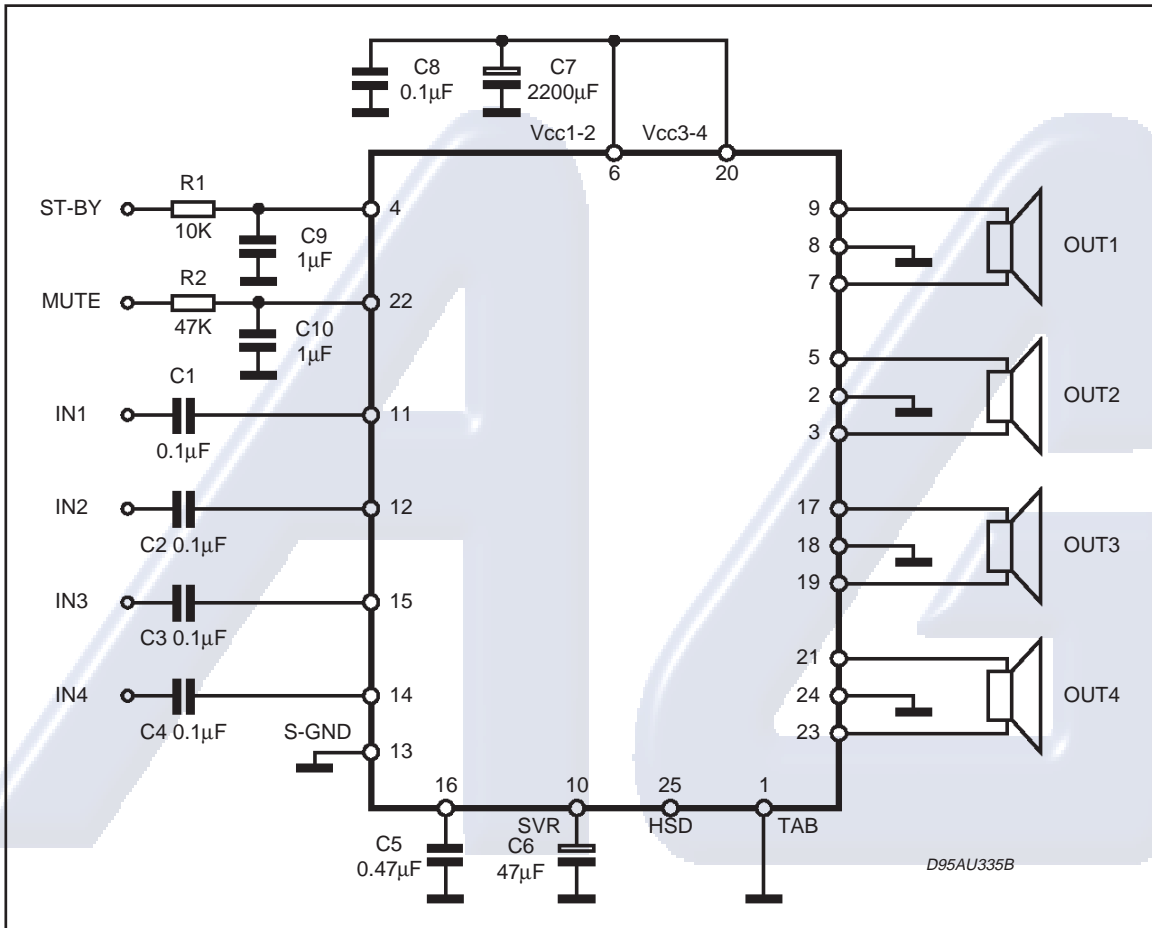

Electrónica S.A. de C.V.

TDA7386

Figure 2: P.C.B. and component layout of the figure 1 (1:1 scale)

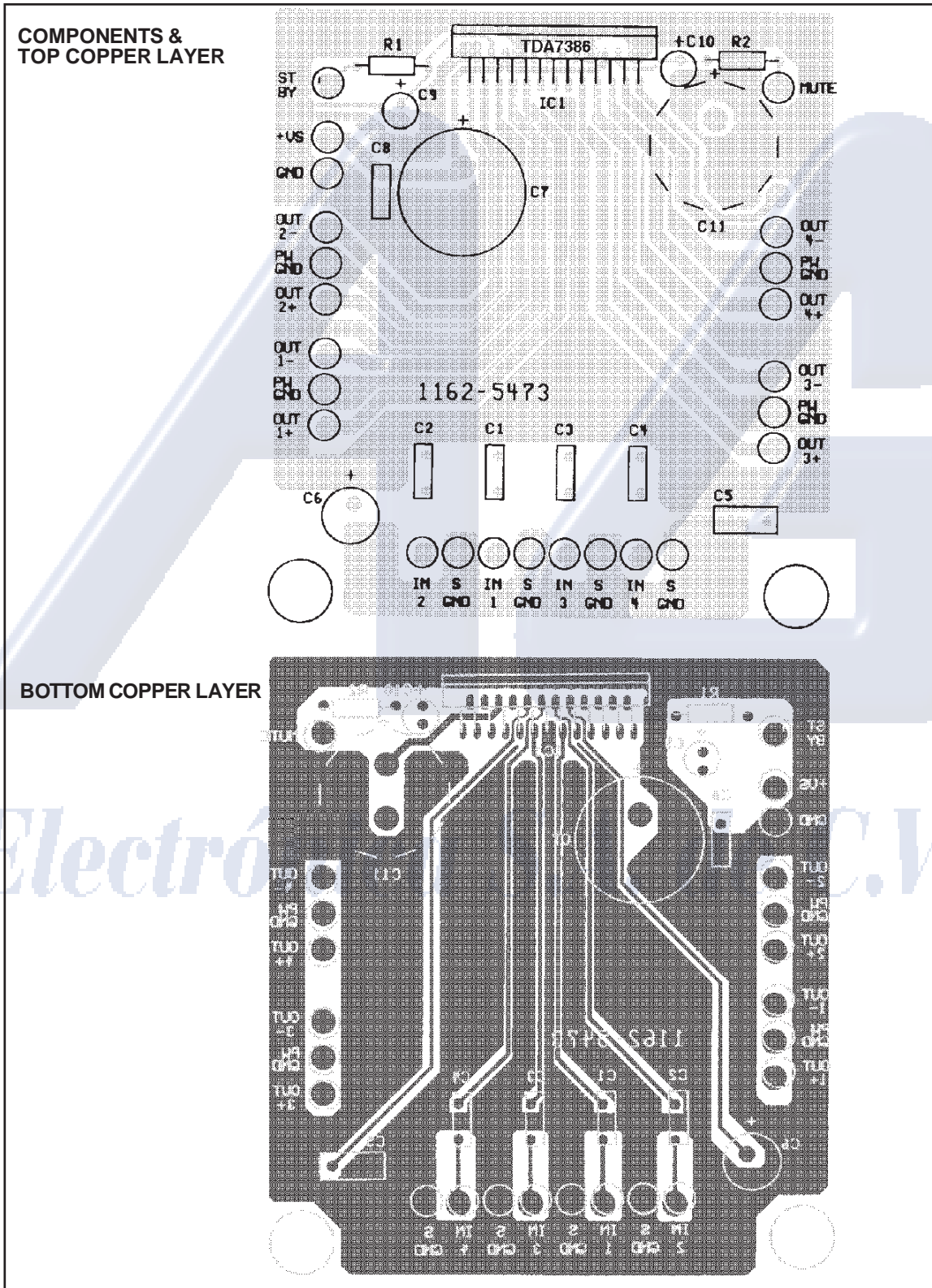

TDA7386

Figure 3: Quiescent Current vs. Supply Voltage

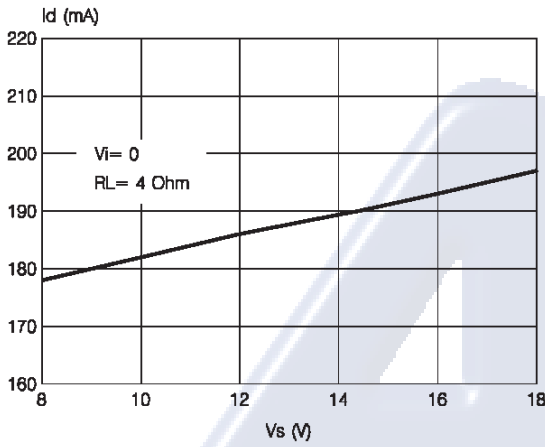

Figure 4: Quiescent Output Voltage vs. Supply Voltage

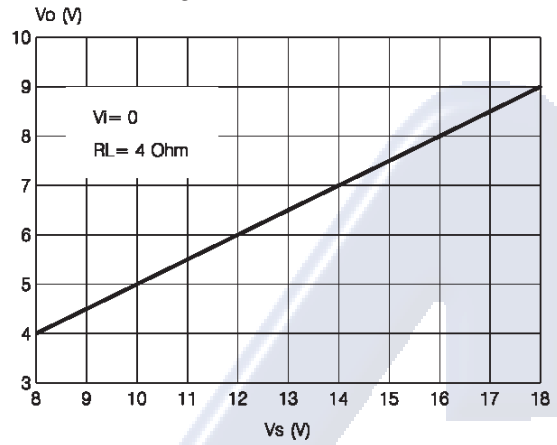

Figure 5: Output Power vs. Supply Voltage

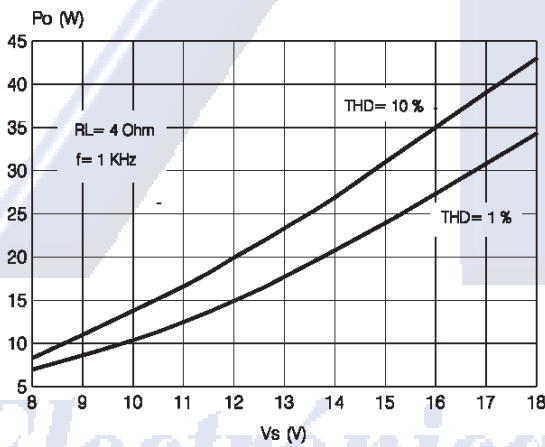

Figure 6: Maximum Output Power vs. Supply Voltage

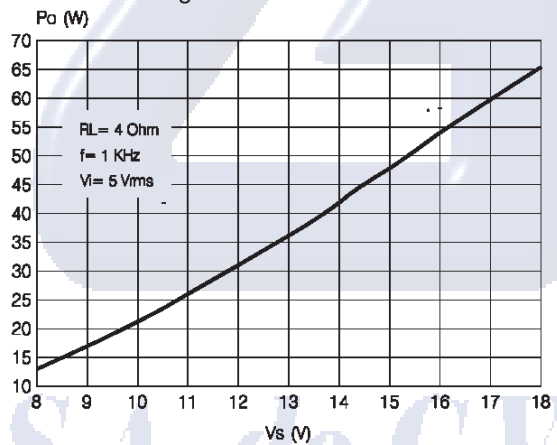

Figure 7: Distortion vs. Output Power

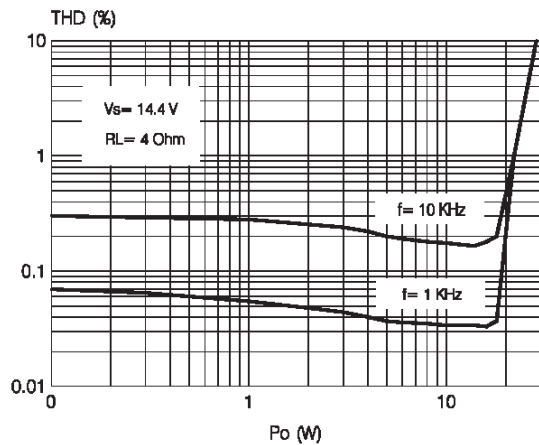

Figure 8: Distortion vs. Frequency

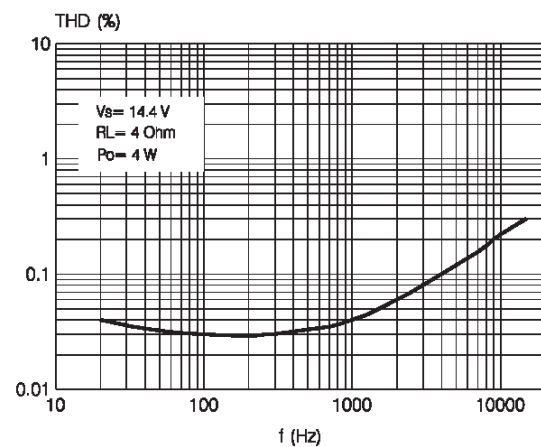

Figure 9: Supply Voltage Rejection vs. Frequency

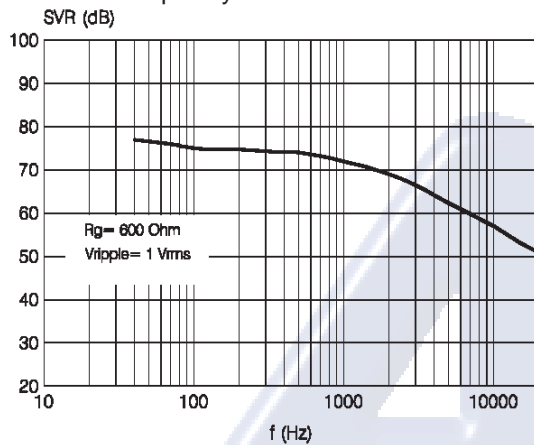

Figure 10: Crosstalk vs. Frequency

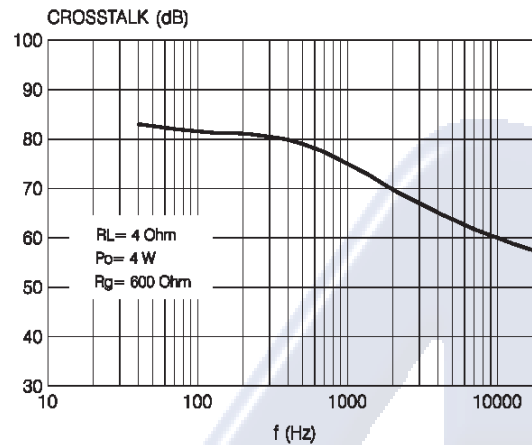

Figure 11: Output Noise vs. Source Resistance

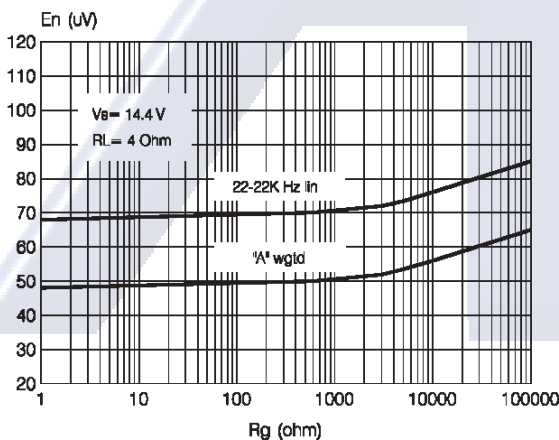
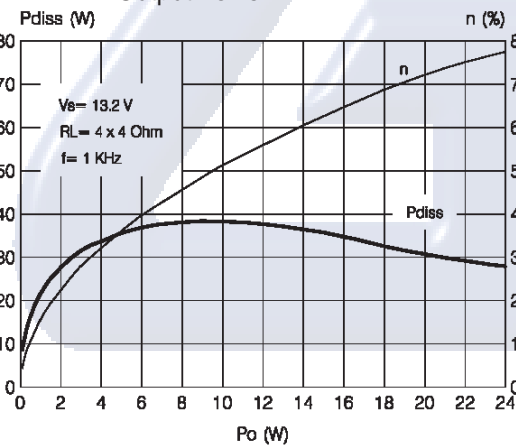

Figure 12: Power Dissipation & Efficiency vs. Output Power



APPLICATION HINTS (ref. to the circuit of fig. 1)

SVR

Besides its contribution to the ripple rejection, the SVR capacitor governs the turn ON/OFF time sequence and, consequently, plays an essential role in the pop optimization during ON/OFF transients. To conveniently serve both needs, **ITS MINIMUM RECOMMENDED VALUE IS 10µF.**

INPUT STAGE

The TDA7386's inputs are ground-compatible and can stand very high input signals ($\pm 8V_{pk}$) without any performances degradation.

If the standard value for the input capacitors (0.1µF) is adopted, the low frequency cut-off will amount to 16 Hz.

STAND-BY AND MUTING

STAND-BY and MUTING facilities are both

CMOS-COMPATIBLE. If unused, a straight connection to V_s of their respective pins would be admissible. Conventional/low-power transistors can be employed to drive muting and stand-by pins in absence of true CMOS ports or microprocessors.

R-C cells have always to be used in order to smooth down the transitions for preventing any audible transient noises.

Since a DC current of about 10 uA normally flows out of pin 22, the maximum allowable muting-series resistance (R_2) is 70KΩ, which is sufficiently high to permit a muting capacitor reasonably small (about 1µF).

If R_2 is higher than recommended, the involved risk will be that the voltage at pin 22 may rise to above the 1.5 V threshold voltage and the device will consequently fail to turn OFF when the mute line is brought down.

About the stand-by, the time constant to be assigned in order to obtain a virtually pop-free transition has to be slower than 2.5V/ms.



TDA7386

DIM.	mm			inch		
	MIN.	TYP.	MAX.	MIN.	TYP.	MAX.
A	4.45	4.50	4.65	0.175	0.177	0.183
B	1.80	1.90	2.00	0.070	0.074	0.079
C		1.40			0.055	
D	0.75	0.90	1.05	0.029	0.035	0.041
E	0.37	0.39	0.42	0.014	0.015	0.016
F (1)			0.57			0.022
G	0.80	1.00	1.20	0.031	0.040	0.047
G1	23.75	24.00	24.25	0.935	0.945	0.955
H (2)	28.90	29.23	29.30	1.138	1.150	1.153
H1		17.00			0.669	
H2		12.80			0.503	
H3		0.80			0.031	
L (2)	22.07	22.47	22.87	0.869	0.884	0.904
L1	18.57	18.97	19.37	0.731	0.747	0.762
L2 (2)	15.50	15.70	15.90	0.610	0.618	0.626
L3	7.70	7.85	7.95	0.303	0.309	0.313
L4		5			0.197	
L5		3.5			0.138	
M	3.70	4.00	4.30	0.145	0.157	0.169
M1	3.60	4.00	4.40	0.142	0.157	0.173
N		2.20			0.086	
O		2			0.079	
R		1.70			0.067	
R1		0.5			0.02	
R2		0.3			0.12	
R3		1.25			0.049	
R4		0.50			0.019	
V					5° (Typ.)	
V1					3° (Typ.)	
V2					20° (Typ.)	
V3					45° (Typ.)	

(1): dam-bar protusion not included
(2): molding protusion included

OUTLINE AND MECHANICAL DATA

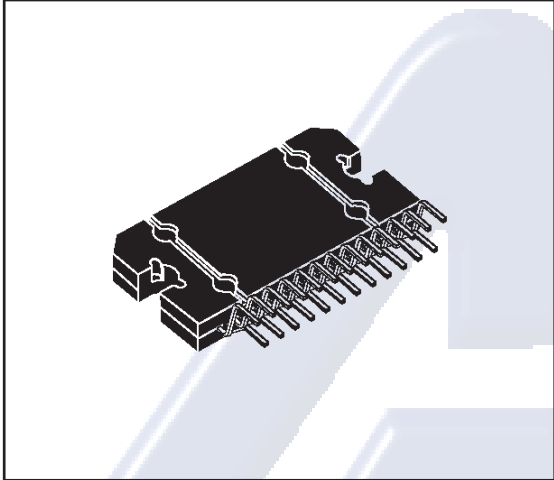

Flexiwatt25

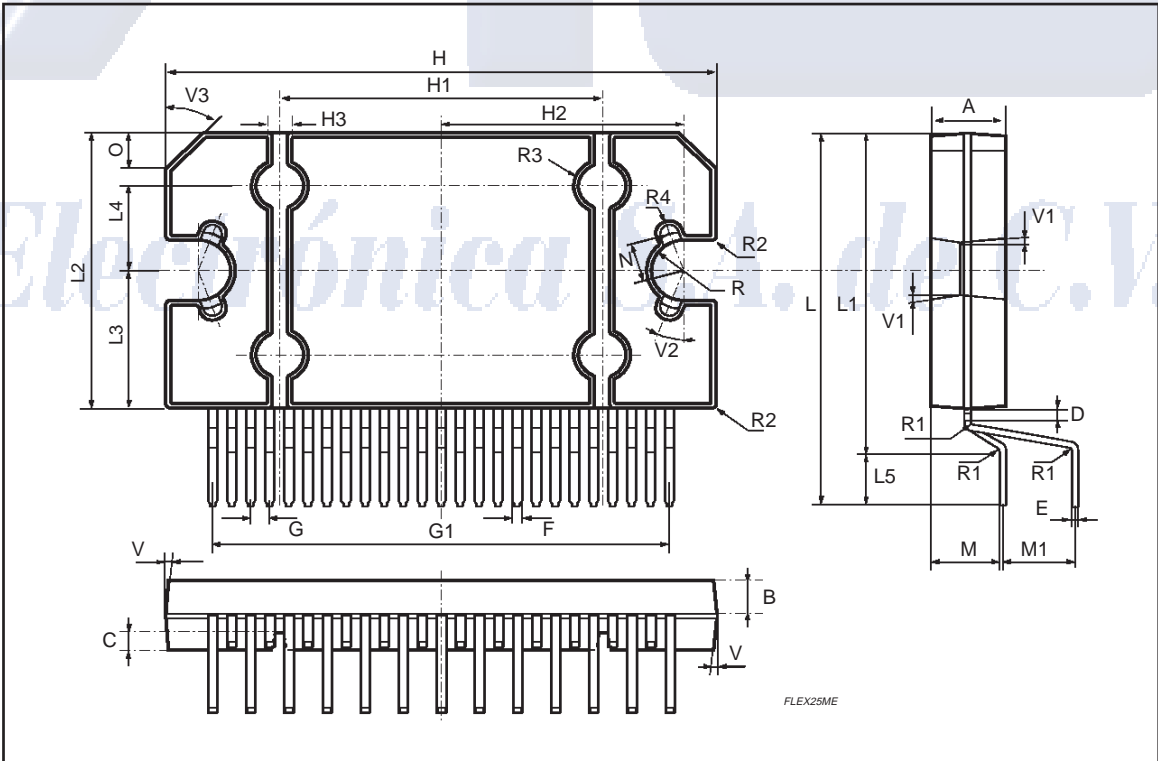

AG

Electrónica S.A. de C.V.

Information furnished is believed to be accurate and reliable. However, STMicroelectronics assumes no responsibility for the consequences of use of such information nor for any infringement of patents or other rights of third parties which may result from its use. No license is granted by implication or otherwise under any patent or patent rights of STMicroelectronics. Specification mentioned in this publication are subject to change without notice. This publication supersedes and replaces all information previously supplied. STMicroelectronics products are not authorized for use as critical components in life support devices or systems without express written approval of STMicroelectronics.

The ST logo is a registered trademark of STMicroelectronics

© 1999 STMicroelectronics – Printed in Italy – All Rights Reserved

STMicroelectronics GROUP OF COMPANIES

Australia - Brazil - China - Finland - France - Germany - Hong Kong - India - Italy - Japan - Malaysia - Malta - Morocco -
Singapore - Spain - Sweden - Switzerland - United Kingdom - U.S.A.

<http://www.st.com>

