

INTEGRATED CIRCUITS

DATA SHEET



TDA9853H

I²C-bus controlled economic BTSC
stereo decoder and audio
processor

Product specification
File under Integrated Circuits, IC02

2000 Dec 11



I²C-bus controlled economic BTSC stereo decoder and audio processor

TDA9853H

FEATURES

- Voltage Controlled Amplifier (VCA) noise reduction circuit
- Stereo or mono selectable at the AF outputs
- Stereo pilot PLL circuit with ceramic resonator
- Automatic pilot cancellation
- I²C-bus transceiver.

Audio processor

- Selector for internal and external signals (line in)
- Automatic Volume Level (AVL) control (control range +6 to -15 dB)
- Volume control (control range +12 to -63 dB)
- Mute control via I²C-bus
- 4 fixed tone settings.



GENERAL DESCRIPTION

The TDA9853H is a bipolar-integrated BTSC stereo decoder and audio processor for application in TV sets, VCRs and multimedia PCs.

ORDERING INFORMATION

TYPE NUMBER	PACKAGE		
	NAME	DESCRIPTION	VERSION
TDA9853H	QFP44	plastic quad flat package; 44 leads (lead length 2.35 mm); body 14 × 14 × 2.2 mm	SOT205-1

I²C-bus controlled economic BTSC stereo decoder and audio processor

TDA9853H

QUICK REFERENCE DATA

SYMBOL	PARAMETER	CONDITIONS	MIN.	TYP.	MAX.	UNIT
V _{CC}	supply voltage		7.8	8	9	V
I _{CC}	supply current		25	33	45	mA
V _{o(rms)}	output voltage (RMS value)	composite input voltage 250 mV (RMS) for 100% modulation L + R (25 kHz deviation); f _{mod} = 300 Hz	–	500	–	mV
α _{csL,R}	stereo channel separation L and R	14% modulation; f _L = 300 Hz; f _R = 3 kHz	15	20	–	dB
THD _{L,R}	total harmonic distortion L and R	100% modulation L or R; f _{mod} = 1 kHz	–	0.2	1	%
S/N	signal-to-noise ratio at line out and at AF output	mono via I ² C-bus; referenced to 500 mV output signal; volume 0 dB CCIR 468-2 weighted; quasi peak DIN noise weighting filter (RMS value)	50 –	60 73	– –	dB dBA
V _{I, O(rms)}	signal handling (RMS value)	THD < 0.5%	2	–	–	V
AVL	AVL control range		–15	–	+6	dB
G _c	volume control range		–63	–	+12	dB
L _{linear}	linear tone control		–	0	–	dB
L _{bass(max)}	tone control with maximum bass	referenced to linear position; f _{mod} = 20 Hz	10	12	–	dB
L _{bass(min)}	tone control with minimum bass	referenced to linear position; f _{mod} = 20 Hz	3.5	5	–	dB
L _{treble(max)}	tone control with maximum treble	referenced to linear position; f _{mod} = 20 kHz	6	8	–	dB
L _{treble(min)}	tone control with minimum treble	referenced to linear position; f _{mod} = 20 kHz	–	–1.5	–	dB

2000 Dec 11

4

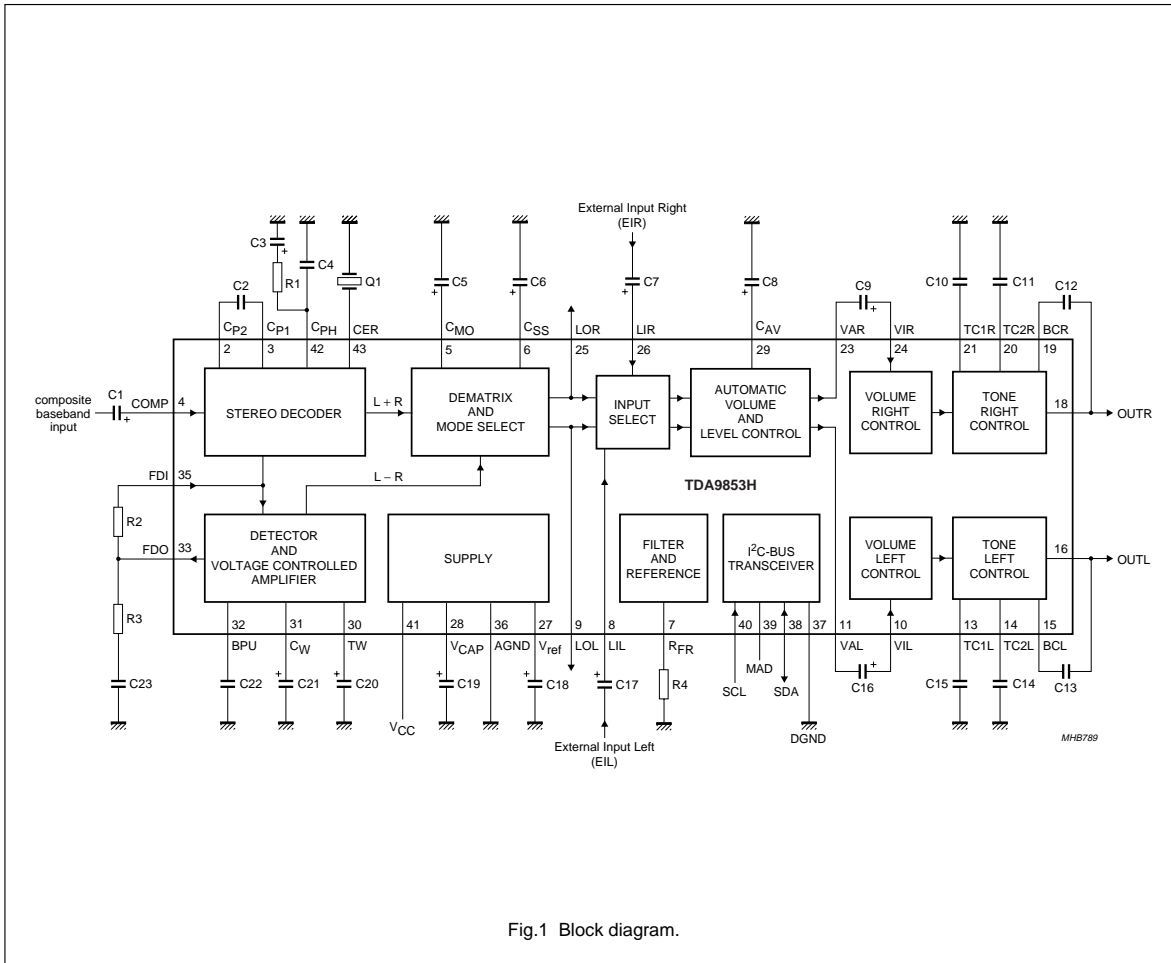

Fig.1 Block diagram.

BLOCK DIAGRAM

i²C-bus controlled economic BTSC stereo decoder and audio processor

TDA9853H

Philips Semiconductors

Product specification

I²C-bus controlled economic BTSC stereo decoder and audio processor

TDA9853H

Component list

Electrolytic capacitors $\pm 20\%$; foil capacitors $\pm 10\%$; resistors $\pm 5\%$; unless otherwise specified; see Fig.1.

COMPONENT	VALUE	TYPE	REMARK
C1	2.2 μ F	electrolytic	63 V
C2	220 nF	foil	
C3	2.2 μ F	electrolytic	63 V
C4	220 nF	foil	
C5	2.2 μ F	electrolytic	63 V
C6	2.2 μ F	electrolytic	63 V
C7	2.2 μ F	electrolytic	63 V
C8	4.7 μ F	electrolytic	63 V $\pm 10\%$
C9	2.2 μ F	electrolytic	63 V
C10	3.3 nF	foil	
C11	150 pF	foil	
C12	56 nF	foil	
C13	56 nF	foil	
C14	150 pF	foil	
C15	3.3 nF	foil	
C16	2.2 μ F	electrolytic	63 V
C17	2.2 μ F	electrolytic	63 V
C18	100 μ F	electrolytic	16 V
C19	100 μ F	electrolytic	16 V
C20	10 μ F	electrolytic	63 V
C21	1 μ F	electrolytic	63 V
C22	4.7 nF	foil	
C23	22 nF	foil	
R1	3.3 k Ω		
R2	15 k Ω		
R3	1.3 k Ω		
R4	100 k Ω		
Q1		CSB503F58	radial leads
		CSB503JF958	alternative as SMD

I²C-bus controlled economic BTSC stereo decoder and audio processor

TDA9853H

PINNING

SYMBOL	PIN	DESCRIPTION
n.c.	1	not connected
C _{P2}	2	connector 2 for pilot detector capacitor
C _{P1}	3	connector 1 for pilot detector capacitor
COMP	4	composite input signal
C _{MO}	5	capacitor for DC-decoupling mono
C _{SS}	6	capacitor for DC-decoupling stereo
R _{FR}	7	resistor for filter reference
LIL	8	line input; left channel
LOL	9	line output; left channel
VIL	10	volume control input; left channel
VAL	11	AVL output; left channel
n.c.	12	not connected
TC1L	13	treble capacitor 1; left channel
TC2L	14	treble capacitor 2; left channel
BCL	15	bass capacitor; left channel
OUTL	16	left channel output
n.c.	17	not connected
OUTR	18	right channel output
BCR	19	bass capacitor; right channel
TC2R	20	treble capacitor 2; right channel
TC1R	21	treble capacitor 1; right channel
n.c.	22	not connected
VAR	23	AVL output; right channel

SYMBOL	PIN	DESCRIPTION
VIR	24	volume control input; right channel
LOR	25	line output; right channel
LIR	26	line input; right channel
V _{ref}	27	reference voltage (0.5V _{CC})
V _{CAP}	28	capacitor for electronic filtering of supply
C _{AV}	29	capacitor for AVL
TW	30	capacitor timing
C _W	31	capacitor for VCA and band-pass filter lower corner frequency
BPU	32	band-pass filter upper corner frequency
FDO	33	fixed de-emphasis output
n.c.	34	not connected
FDI	35	fixed de-emphasis input
AGND	36	analog ground
DGND	37	digital ground
SDA	38	serial data input/output
MAD	39	programmable address bit (module address)
SCL	40	serial clock input
V _{CC}	41	supply voltage
C _{PH}	42	capacitor for phase detector
CER	43	ceramic resonator
n.c.	44	not connected

I²C-bus controlled economic BTSC stereo decoder and audio processor

TDA9853H

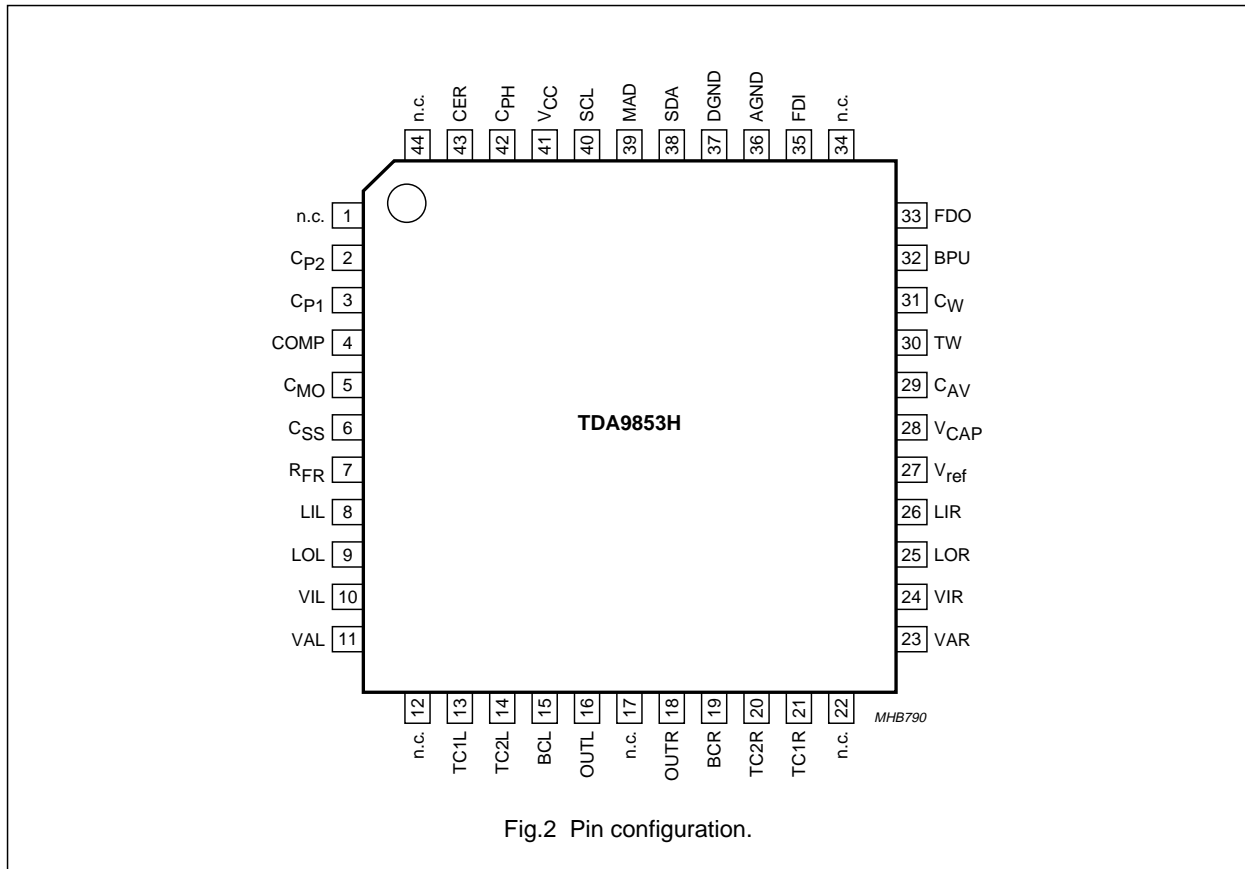

FUNCTIONAL DESCRIPTION

Stereo decoder

The composite signal is fed into a pilot detector/pilot cancellation circuit and into the MPX demodulator. The main L + R signal passes a 75 μ s fixed de-emphasis filter and is fed into the dematrix circuit. The decoded sub-signal L – R is applied to the Volume Controlled Amplifier (VCA) circuit. To generate the pilot signal the stereo demodulator uses a PLL circuit including a ceramic resonator.

Mode selection

The L – R signal is fed via the internal VCA circuit to the dematrix/switching circuit. Mode selection is achieved via the I²C-bus (see Table 9).

The dematrix outputs can be muted via the I²C-bus (see Table 14).

Automatic volume level control

The automatic volume level stage controls its output voltage to a constant level of typically 200 mV (RMS) from an input voltage range between 0.1 to 1.1 V (RMS). The circuit adjusts variations in modulation during broadcasting and because of changes in the programme material; this function can be switched off. To avoid audible plops during the permanent operation of the AVL circuit a soft blending scheme has been applied between the different gain stages. A capacitor (4.7 μ F) at pin C_{AV} determines the attack and decay time constants. In addition the ratio of attack and decay times can be changed via the I²C-bus.

Integrated filters

The filter functions necessary for stereo demodulation are provided on-chip using transistor circuits. The filter frequencies are controlled by the filter reference circuit via the external resistor R4.

I²C-bus controlled economic BTSC stereo decoder and audio processor

TDA9853H

Audio processor

SELECTOR

The selector enables the selection of either the internal line output signals LOR and LOL (dematrix output) or the external line input signals LIR and LIL (see Table 16). The input signal capability of the line inputs (LIR/LIL) is 2 V (RMS). The output of the selector is DC-coupled to the automatic volume level control circuit.

VOLUME

The volume control range is from +12 dB to -63 dB in steps of 1 dB and ends with a mute step (see Table 8). Balance control is achieved by the independent volume control of each channel.

BASS FUNCTION

A single external 56 nF capacitor for each channel in combination with a linear operational amplifier and internal resistors provides a bass range of +12 dB for high bass and +5 dB for low bass.

TREBLE FUNCTION

Two external capacitors C15 = 3.3 nF and C14 = 150 pF for each channel in combination with a linear operational amplifier and internal resistors provide a treble range of +8 dB for high treble and -1.5 dB for low treble.

MUTE

The mute function can be activated independently with the last step of volume control at the left or right output. By setting the general mute bit GMU the audio outputs OUTL and OUTR are muted.

LIMITING VALUES

In accordance with the Absolute Maximum Rating System (IEC 60134).

SYMBOL	PARAMETER	CONDITIONS	MIN.	MAX.	UNIT
V _{CC}	supply voltage		-	9.5	V
V _{SDA} , V _{SCL}	voltage at pins SDA and SCL referenced to GND	V _{CC} ≤ 9 V	-0.3	+V _{CC}	V
		V _{CC} > 9 V	-0.3	+9	V
V _n	voltage of all other pins to GND		0	V _{CC}	V
T _{amb}	ambient temperature		-20	+70	°C
T _{stg}	storage temperature		-65	+150	°C
V _{es}	electrostatic handling voltage	note 1	-200	+200	V
		note 2	-2000	+2000	V

Notes

- Machine model class B, equivalent to discharging a 200 pF capacitor through a 0 Ω series resistor ('0 Ω' is actually 0.75 μH + 10 Ω).
- Human body model class B, equivalent to discharging a 100 pF capacitor through a 1500 Ω series resistor.

THERMAL CHARACTERISTICS

SYMBOL	PARAMETER	CONDITIONS	VALUE	UNIT
R _{th(j-a)}	thermal resistance from junction to ambient	in free air	70	K/W

I²C-bus controlled economic BTSC stereo decoder and audio processor

TDA9853H

CHARACTERISTICS

All voltages are measured relative to GND; $V_{CC} = 8\text{ V}$; $R_s = 600\ \Omega$; AC-coupled; $R_L = 10\text{ k}\Omega$; $C_L = 2.5\text{ nF}$; $f_{mod} = 1\text{ kHz}$ mono signal; composite input voltage 250 mV (RMS) for 100% modulation L + R (25 kHz deviation); pilot 50 mV (RMS); $G_v = 0\text{ dB}$; linear tone control; AVL off; $T_{amb} = 25\text{ }^\circ\text{C}$; see Fig.1; unless otherwise specified.

SYMBOL	PARAMETER	CONDITIONS	MIN.	TYP.	MAX.	UNIT
Supplies						
V_{CC}	supply voltage		7.8	8	9	V
I_{CC}	supply current		25	33	45	mA
V_{ref}	internal reference voltage at pin V_{ref}		$0.45V_{CC}$	$0.5V_{CC}$	$0.55V_{CC}$	V
Input stage						
$V_{i(max)(rms)}$	maximum input voltage (RMS value)		2	–	–	V
Z_i	input impedance		20	25	32	k Ω
Stereo decoder						
HR	headroom for L + R, L and R	$f_{mod} = 300\text{ Hz}$; THD < 15%	9	–	–	dB
$V_{pil(rms)}$	nominal stereo pilot voltage (RMS value)		–	50	–	mV
$V_{th(on)(rms)}$	pilot threshold voltage, stereo on (RMS value)		–	–	35	mV
$V_{th(off)(rms)}$	pilot threshold voltage, stereo off (RMS value)		15	–	–	mV
hys	hysteresis		–	2.5	–	dB
$V_{o(rms)}$	output voltage (RMS value)	100% modulation L + R; $f_{mod} = 300\text{ Hz}$	–	500	–	mV
$\alpha_{cs(L,R)}$	stereo channel separation L and R	14% modulation; $f_L = 300\text{ Hz}$; $f_R = 3\text{ kHz}$	15	20	–	dB
THD _{L,R}	total harmonic distortion L and R	100% modulation L or R; $f_{mod} = 1\text{ kHz}$	–	0.2	1	%
S/N	signal-to-noise ratio at line output and AF output	mono via I ² C-bus; referenced to 500 mV output signal CCIR 468-2 weighted; quasi peak DIN noise weighting filter (RMS value)	50	60	–	dB
			–	73	–	dBA
α_{mute}	mute attenuation at LOL, LOR, VAL and VAR	100% modulation L + R; $f_{mod} = 300\text{ Hz}$; mute via bit E6	63	–	–	dB
Stereo decoder, oscillator (VCXO); note 1						
f_o	nominal VCXO output frequency (32 f_H)	with nominal ceramic resonator	–	503.5	–	kHz
Δf_{fr}	spread of free-running frequency	with nominal ceramic resonator	500	–	507	kHz
Δf_{cr}	capture range frequency	nominal pilot	± 190	± 265	–	Hz

I²C-bus controlled economic BTSC stereo decoder and audio processor

TDA9853H

SYMBOL	PARAMETER	CONDITIONS	MIN.	TYP.	MAX.	UNIT
Audio control part; input pins VIL and VIR to pins OUTL and OUTR						
V _O	DC output voltage		0.45V _{CC}	0.5V _{CC}	0.55V _{CC}	V
Z _i	volume input impedance		25	30	38	kΩ
Z _o	output impedance		–	80	120	Ω
R _L	output load resistance		5	–	–	kΩ
C _L	output load capacitance		0	–	2.5	nF
V _{i(max)(rms)}	maximum input voltage (RMS value)	THD < 0.5%	tbf	2	–	V
THD	total harmonic distortion	1 V (RMS) input voltage	–	0.05	–	%
V _{no}	noise output voltage	CCIR 468-2 weighted; quasi peak				
		G _v = 10 dB	–	110	220	μV
		G _v = 0 dB	–	33	50	μV
		mute position	–	10	–	μV
G _c	volume control range	maximum boost	–	12	–	dB
		maximum attenuation	–	63	–	dB
G _{step}	step resolution		–	1	–	dB
	step error between adjoining step	G _v = +12 to –15 dB and G _v = –16 to –63 dB; note 2	–	–	0.5	dB
ΔG _a	attenuator set error	G _v = +12 to –50 dB	–	–	2	dB
		G _v = –51 to –63 dB	–	–	3	dB
ΔG _L	gain tracking error	G _v = +12 to –50 dB	–	–	2	dB
α _m	mute attenuation		80	–	–	dB
V _{DC(OS)}	DC step offset between any adjacent step	G _v = +12 to 0 dB	–	0.2	10	mV
		G _v = 0 to –63 dB	–	–	5	mV
	DC step offset between any step to mute	G _v = +12 to 0 dB	–	2	15	mV
		G _v = –1 to –63 dB	–	1	10	mV
Tone control part						
L _{linear}	linear tone control		–	0	–	dB
L _{bass(max)}	tone control with maximum bass	referenced to linear position; f _{mod} = 20 Hz	10	12	–	dB
L _{bass(min)}	tone control with minimum bass	referenced to linear position; f _{mod} = 20 Hz	3.5	5	–	dB
L _{treble(max)}	tone control with maximum treble	referenced to linear position; f _{mod} = 20 kHz	6	8	–	dB
L _{treble(min)}	tone control with minimum treble	referenced to linear position; f _{mod} = 20 kHz	–	–1.5	–	dB

I²C-bus controlled economic BTSC stereo decoder and audio processor

TDA9853H

SYMBOL	PARAMETER	CONDITIONS	MIN.	TYP.	MAX.	UNIT
VCA						
I_s	nominal timing current for nominal release rate of VCA detector	I_s can be measured at pin TW via current meter connected to $0.5V_{CC} + 1 V$	6.5	8	9.5	μA
Rel_{rate}	nominal detector release rate	nominal timing current and external capacitor values	–	125	–	dB/s
Automatic volume level control						
G_v	voltage gain	maximum boost; note 3	5	6	7	dB
		maximum attenuation; note 3	14	15	16	dB
G_{step}	equivalent step width between the input stages (soft switching system)		–	1.5	–	dB
$V_{i(rms)}$	input voltage (RMS value)	maximum boost; note 3	–	0.1	–	V
		maximum attenuation; note 3	–	1.125	–	V
$V_{o(AVL)(rms)}$	output voltage in AVL operation (RMS value)		160	200	250	mV
$V_{offset(DC)}$	DC offset voltage between different gain steps	voltage at pin C_{AV} 6 to 5.83 V or 5.83 to 5.61 V or 5.61 to 4.83 V or 4.83 to 2.1 V; note 4	–	–	20	mV
R_{att}	discharge resistors for attack time constant	AT1 = 0; AT2 = 0; note 5	340	420	520	Ω
		AT1 = 1; AT2 = 0; note 5	590	730	910	Ω
		AT1 = 0; AT2 = 1; note 5	0.96	1.2	1.5	k Ω
		AT1 = 1; AT2 = 1; note 5	1.7	2.1	2.6	k Ω
I_{dec}	charge current for decay time	normal mode; CCD = 0; note 6	1.6	2	2.4	μA
		Power-on speed-up; CCD = 1; note 6	–	30	–	μA
Selector internal and external						
Z_i	input impedance		16	20	25	k Ω
α_s	input isolation of one selected source to the other input	$V_i = 1 V$; $f_i = 1 kHz$	70	76	–	dB
		$V_i = 1 V$; $f_i = 12.5 kHz$	70	76	–	dB
$V_{i(max)(rms)}$	maximum input voltage (RMS value)	THD < 0.5%	–	2	–	V
G_v	voltage gain, selector		–	0	–	dB
Line output; pins LOL and LOR						
$V_{o(rms)}$	nominal output voltage (RMS value)	100% modulation	–	500	–	mV
HR_o	output headroom		9	–	–	dB
Z_o	output impedance		–	80	120	Ω
V_o	DC output voltage		$0.45V_{CC}$	$0.5V_{CC}$	$0.55V_{CC}$	V
R_L	output load resistance		5	–	–	k Ω
C_L	output load capacitance		–	–	2.5	nF

I²C-bus controlled economic BTSC stereo decoder and audio processor

TDA9853H

SYMBOL	PARAMETER	CONDITIONS	MIN.	TYP.	MAX.	UNIT
Monitor output; pins VAL and VAR						
V _O	DC output voltage		–	0.5V _{CC}	–	V
R _L	output load resistance		5	–	–	kΩ
C _L	output load capacitance	with 100 Ω in series	–	–	2.5	nF
Muting at power supply voltage drop for OTR and OUTL						
ΔV _{CC}	supply voltage drop for mute active		–	V _{CAP} – 0.7	–	V
Power-on reset; note 7						
V _{POR(start)}	start of reset voltage	increasing supply voltage	–	–	2.5	V
		decreasing supply voltage	–	tbf	–	V
V _{POR(end)}	end of reset voltage	increasing supply voltage	–	tbf	–	V
Digital part (I²C-bus pins); note 8						
V _{IH}	HIGH-level input voltage		3	–	V _{CC} ⁽⁹⁾	V
V _{IL}	LOW-level input voltage		–0.3	–	+1.5	V
I _{IH}	HIGH-level input current		–10	–	+10	μA
I _{IL}	LOW-level input current		–10	–	+10	μA
V _{OL}	LOW-level output voltage	I _{IL} = 3 mA	–	–	0.4	V

Notes

- The oscillator is designed to operate together with Murata resonator CSB503F58 or CSB503JF958 as SMD. Change of the resonator supplier is possible, but the resonator specification must be close to the specified ones.
- 1.5 dB step error between –15 and –16 dB.
- The AVL input voltage is internal. It corresponds to the output voltage OUTL and OTR at AVL off.
- The listed pin voltage corresponds with typical gain steps of +6 dB, +3 dB, 0 dB, –6 dB and –15 dB.
- Attack time constant = C_{CAV} × R_{att} with C_{CAV} = C8 (see Fig.1).

$$6. \text{ Decay time} = \frac{C_{CAV} \times 0.76 \text{ V} \left(10^{\frac{-G_1}{20}} - 10^{\frac{-G_2}{20}} \right)}{I_{dec}}$$

- Example: C_{CAV} = 4.7 μF; I_{dec} = 2 μA; G₁ = –9 dB; G₂ = +6 dB → decay time results in 4.14 s.
- When reset is active the GMU bit (mute) is set and the I²C-bus receiver is in the reset position.
 - The AC characteristics are in accordance with the I²C-bus specification for standard mode (clock frequency maximum 100 kHz). A higher frequency, up to 280 kHz, can be used if all clock and data times are interpolated between standard mode (100 kHz) and fast mode (400 kHz) in accordance with the I²C-bus specification. Information about the I²C-bus can be found in brochure "I²C-bus and how to use it" (order number 9398 393 40011).
 - Maximum 9 V if V_{CC} > 9 V.

I²C-bus controlled economic BTSC stereo decoder and audio processor

TDA9853H

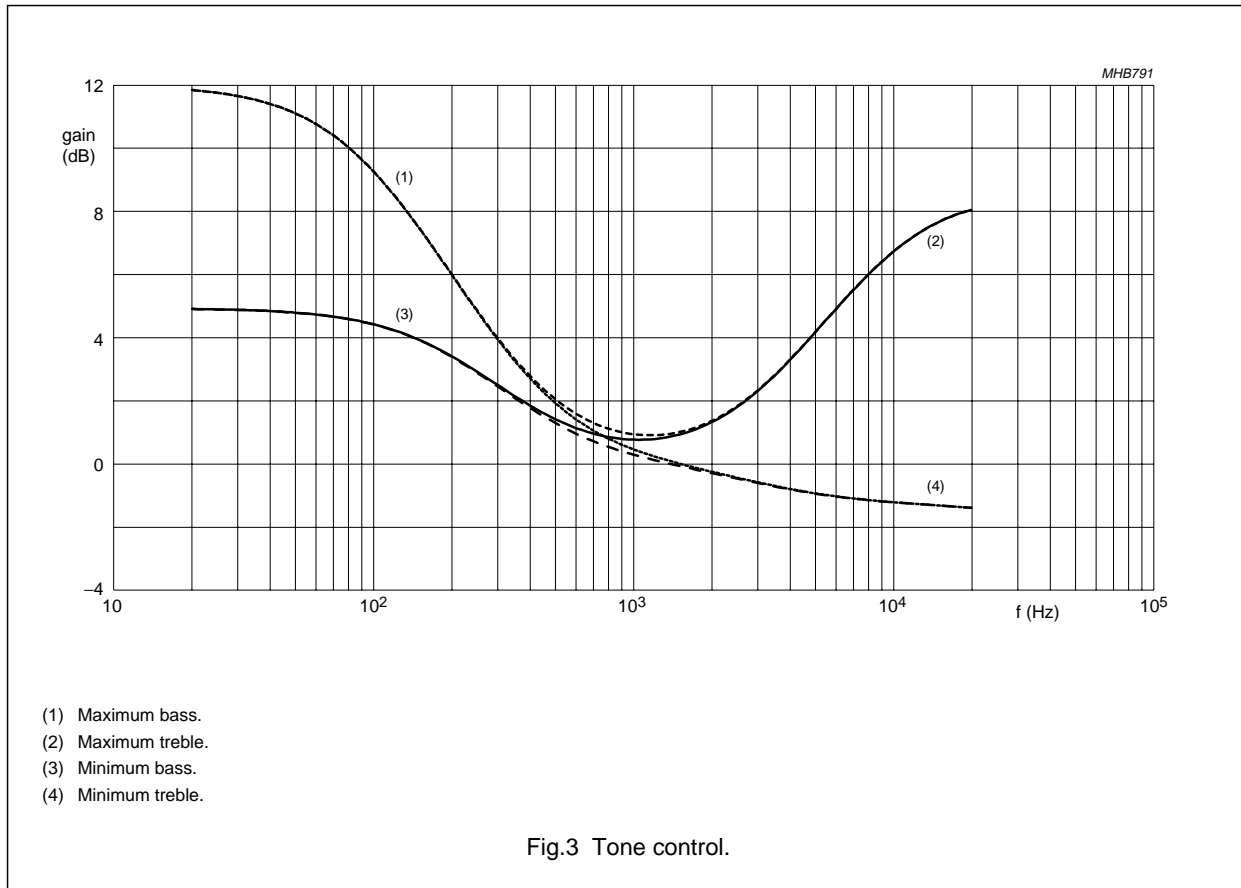

I²C-bus controlled economic BTSC stereo decoder and audio processor

TDA9853H

I²C-BUS PROTOCOL

I²C-bus format to read (slave transmits data)

S	SLAVE ADDRESS	R/ \bar{W}	A	DATA	AN	P
---	---------------	--------------	---	------	----	---

Table 1 Explanation of I²C-bus format to read (slave transmits data)

NAME	DESCRIPTION
S	START condition; generated by the master
Standard SLAVE ADDRESS (MAD)	1011011; pin MAD not connected
Pin programmable SLAVE ADDRESS	1011010; pin MAD connected to ground
R/ \bar{W}	logic 1 (read); generated by the master
A	acknowledge; generated by the slave
DATA	slave transmits an 8-bit data word
AN	acknowledge not; generated by the master
P	STOP condition; generated by the master

Table 2 Definition of the transmitted bytes after read condition

MSB						LSB	
D7	D6	D5	D4	D3	D2	D1	D0
Y	Y	Y	Y	Y	Y	PONR	STP

Table 3 Bit functions of Table 2

BIT	FUNCTION
STP	stereo pilot identification (stereo received = 1)
PONR	Power-on reset; if PONR = 1, then Power-on reset is detected
Y	indefinite

I²C-bus format to write (slave receives data)

S	SLAVE ADDRESS	R/ \bar{W}	A	SUBADDRESS	A	DATA	A	P
---	---------------	--------------	---	------------	---	------	---	---

Table 4 Explanation of I²C-bus format to write (slave receives data)

NAME	DESCRIPTION
S	START condition
Standard SLAVE ADDRESS	101 101 1; pin MAD not connected
Pin programmable SLAVE ADDRESS	101 101 0; pin MAD connected to ground
R/ \bar{W}	logic 0 (write)
A	acknowledge; generated by the slave
SUBADDRESS (SAD)	see Table 5
DATA	see Table 6
P	STOP condition

I²C-bus controlled economic BTSC stereo decoder and audio processor

TDA9853H

If more than 1 byte of DATA is transmitted, then auto-increment is performed, starting from the transmitted subaddress and auto-increment of subaddress in accordance with the order of Table 5 is performed.

Table 5 Subaddress definition (second byte after slave address)

FUNCTION	MSB							LSB	
	D7	D6	D5	D4	D3	D2	D1 ⁽¹⁾	D0 ⁽¹⁾	
Volume right	0	0	0	0	0	0	0	0	
Volume left	0	0	0	0	0	0	0	1	
Control 1	0	0	0	0	0	0	1	0	
Control 2	0	0	0	0	0	0	1	1	

Note

1. Significant subaddress bits.

Table 6 Data definition (third byte after slave address)

FUNCTION	MSB							LSB	
	D7	D6	D5	D4	D3	D2	D1	D0	
Volume right	0	B6	B5	B4	B3	B2	B1	B0	
Volume left	0	C6	C5	C4	C3	C2	C1	C0	
Control 1	0	E6	E5	E4	E3	E2	E1	E0	
Control 2	0	0	0	F4	F3	F2	F1	F0	

Table 7 Bit functions of Table 6

BITS	SYMBOL	FUNCTION
B0 to B6	VR0 to VR6	volume control right
C0 to C6	VL0 to VL6	volume control left
E0	STEREO	mode selection for line out
E1	GMU	mute control for OUTL and OUTF
E2	AVLON	AVL on/off
E3	CCD	increased AVL decay current on/off
E4 and E5	AT1 and AT2	attack time at AVL
E6	LMU	line out mute on/off
F0 and F1	TONE	selection between four fixed tone controls
F2	MODE	selection between intern and extern
F3	MONO	forced mono on/off at OUTL and OUTF
F4	LITO	linear tone control on/off

I²C-bus controlled economic BTSC stereo decoder and audio processor

TDA9853H

Table 8 Volume setting

FUNCTION G _v (dB)	DATA						
	V6	V5	V4	V3	V2	V1	V0
12	1	1	1	1	0	1	1
11	1	1	1	1	0	1	0
10	1	1	1	1	0	0	1
9	1	1	1	1	0	0	0
8	1	1	1	0	1	1	1
7	1	1	1	0	1	1	0
6	1	1	1	0	1	0	1
5	1	1	1	0	1	0	0
4	1	1	1	0	0	1	1
3	1	1	1	0	0	1	0
2	1	1	1	0	0	0	1
1	1	1	1	0	0	0	0
0	1	1	0	1	1	1	1
-1	1	1	0	1	1	1	0
-2	1	1	0	1	1	0	1
-3	1	1	0	1	1	0	0
-4	1	1	0	1	0	1	1
-5	1	1	0	1	0	1	0
-6	1	1	0	1	0	0	1
-7	1	1	0	1	0	0	0
-8	1	1	0	0	1	1	1
-9	1	1	0	0	1	1	0
-10	1	1	0	0	1	0	1
-11	1	1	0	0	1	0	0
-12	1	1	0	0	0	1	1
-13	1	1	0	0	0	1	0
-14	1	1	0	0	0	0	1
-15	1	1	0	0	0	0	0
-16	1	0	1	1	1	1	1
-17	1	0	1	1	1	1	0
-18	1	0	1	1	1	0	1
-19	1	0	1	1	1	0	0
-20	1	0	1	1	0	1	1
-21	1	0	1	1	0	1	0
-22	1	0	1	1	0	0	1
-23	1	0	1	1	0	0	0
-24	1	0	1	0	1	1	1
-25	1	0	1	0	1	1	0

I²C-bus controlled economic BTSC stereo decoder and audio processor

TDA9853H

FUNCTION G _v (dB)	DATA						
	V6	V5	V4	V3	V2	V1	V0
-26	1	0	1	0	1	0	1
-27	1	0	1	0	1	0	0
-28	1	0	1	0	0	1	1
-29	1	0	1	0	0	1	0
-30	1	0	1	0	0	0	1
-31	1	0	1	0	0	0	0
-32	1	0	0	1	1	1	1
-33	1	0	0	1	1	1	0
-34	1	0	0	1	1	0	1
-35	1	0	0	1	1	0	0
-36	1	0	0	1	0	1	1
-37	1	0	0	1	0	1	0
-38	1	0	0	1	0	0	1
-39	1	0	0	1	0	0	0
-40	1	0	0	0	1	1	1
-41	1	0	0	0	1	1	0
-42	1	0	0	0	1	0	1
-43	1	0	0	0	1	0	0
-44	1	0	0	0	0	1	1
-45	1	0	0	0	0	1	0
-46	1	0	0	0	0	0	1
-47	1	0	0	0	0	0	0
-48	0	1	1	1	1	1	1
-49	0	1	1	1	1	1	0
-50	0	1	1	1	1	0	1
-51	0	1	1	1	1	0	0
-52	0	1	1	1	0	1	1
-53	0	1	1	1	0	1	0
-54	0	1	1	1	0	0	1
-55	0	1	1	1	0	0	0
-56	0	1	1	0	1	1	1
-57	0	1	1	0	1	1	0
-58	0	1	1	0	1	0	1
-59	0	1	1	0	1	0	0
-60	0	1	1	0	0	1	1
-61	0	1	1	0	0	1	0
-62	0	1	1	0	0	0	1
-63	0	1	1	0	0	0	0
Mute	0	1	0	1	1	1	1

I²C-bus controlled economic BTSC stereo decoder and audio processor

TDA9853H

Table 9 Mode setting

FUNCTION MODE		READABLE BIT D0/STP	SETTING BIT E0/STEREO
LOL	LOR		
Left	right	logic 1 (stereo received)	1
Mono	mono	logic 1 (stereo received)	0
Mono	mono	logic 0 (no stereo received)	1
Mono	mono	logic 0 (no stereo received)	0

Table 10 Mute setting

FUNCTION	DATA
MUTE CONTROL FOR OUTR AND OUTL	E1
Forced mute at OUTR and OUTL	1
No forced mute at OUTR and OUTL	0

Table 11 AVLON bit setting

FUNCTION	DATA
AVL	E2
Automatic volume control on	1
Automatic volume control off	0

Table 12 CCD bit setting

FUNCTION	DATA
AVL CURRENT	E3
Increased load current	1
Load current for normal AVL decay time	0

Table 13 AVL attack time; see Chapter "Characteristics" note 5

FUNCTION	DATA	
	E5	E4
R_{att} (Ω)		
420	0	0
730	0	1
1200	1	0
2100	1	1

Table 14 Line out mute setting

FUNCTION	DATA
MUTE LINE OUTPUT	E6
Line output mute	1
Line output active	0

Table 15 Tone setting

TONE	DATA	
	F1	F0
Maximum bass and maximum treble	1	1
Maximum bass and minimum treble	1	0
Minimum bass and maximum treble	0	1
Minimum bass and minimum treble	0	0

Table 16 Selector setting

FUNCTION	DATA
MODE INTERNAL/EXTERNAL	F2
External left and right	1
Internal left and right	0

Table 17 Mono setting

FUNCTION	DATA
MONO AT OUTL AND OUTR	F3
Forced mono	1
No forced mono	0

Table 18 Linear setting

FUNCTION	DATA
MODE TONE	F4
Linear	1
Tone	0

I²C-bus controlled economic BTSC stereo decoder and audio processor

TDA9853H

INTERNAL PIN CONFIGURATIONS

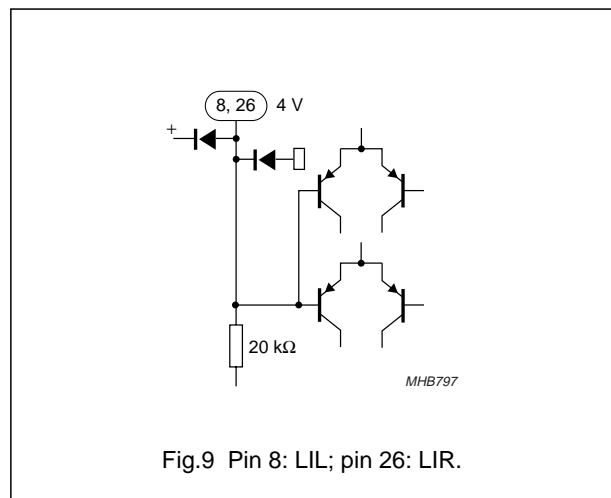
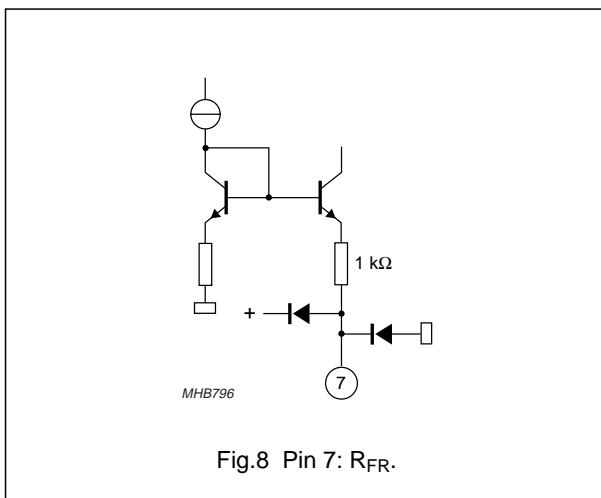
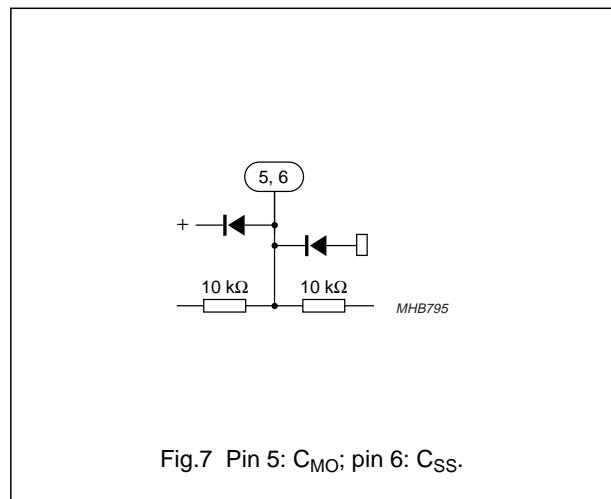
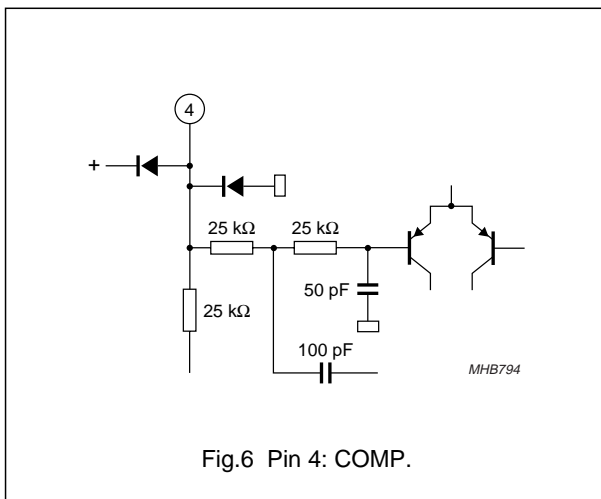
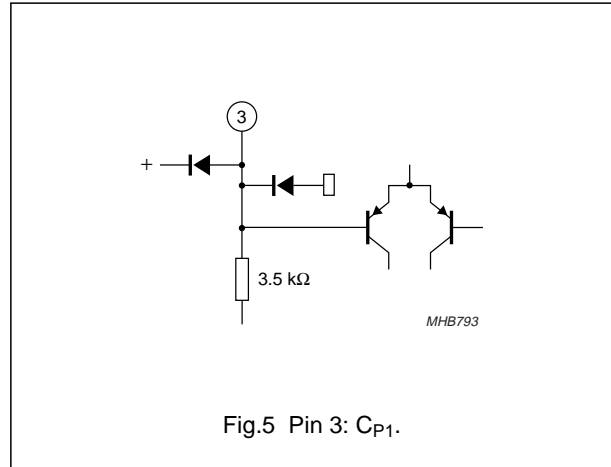
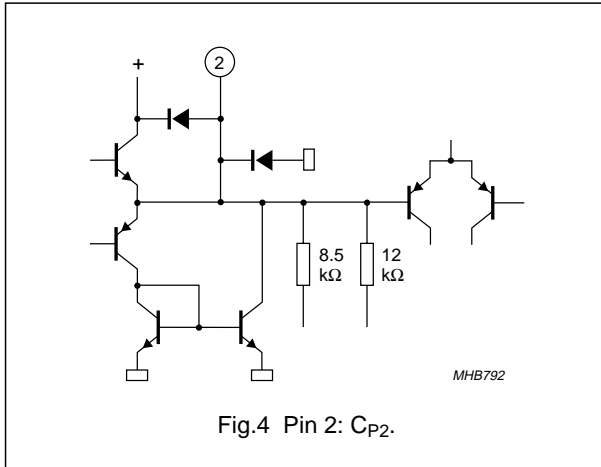

I²C-bus controlled economic BTSC stereo decoder and audio processor

TDA9853H

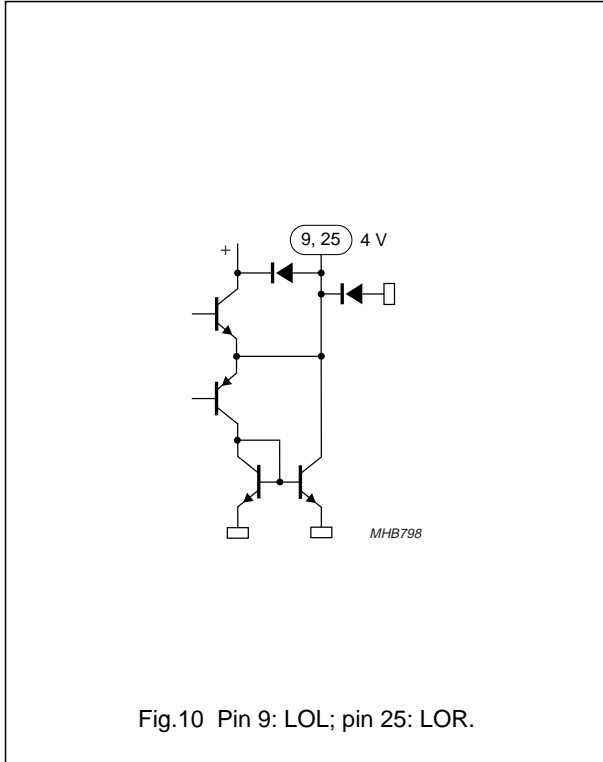

Fig.10 Pin 9: LOL; pin 25: LOR.

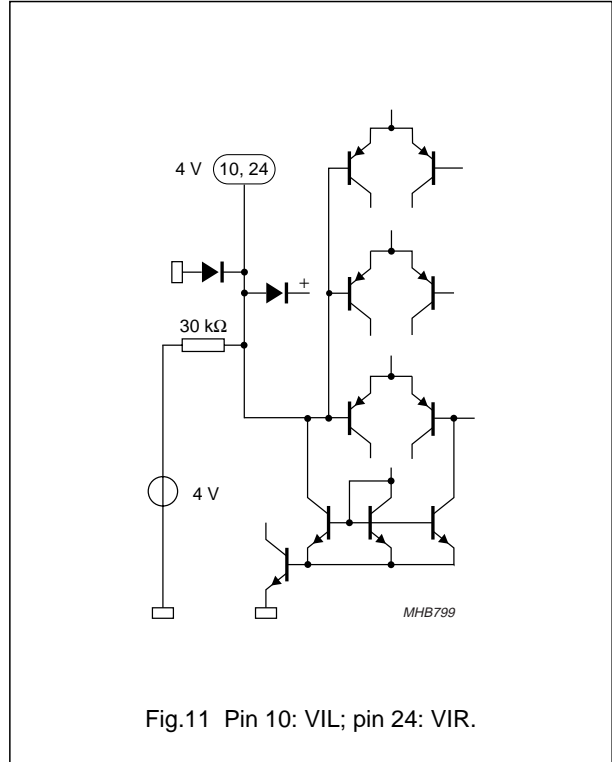

Fig.11 Pin 10: VIL; pin 24: VIR.

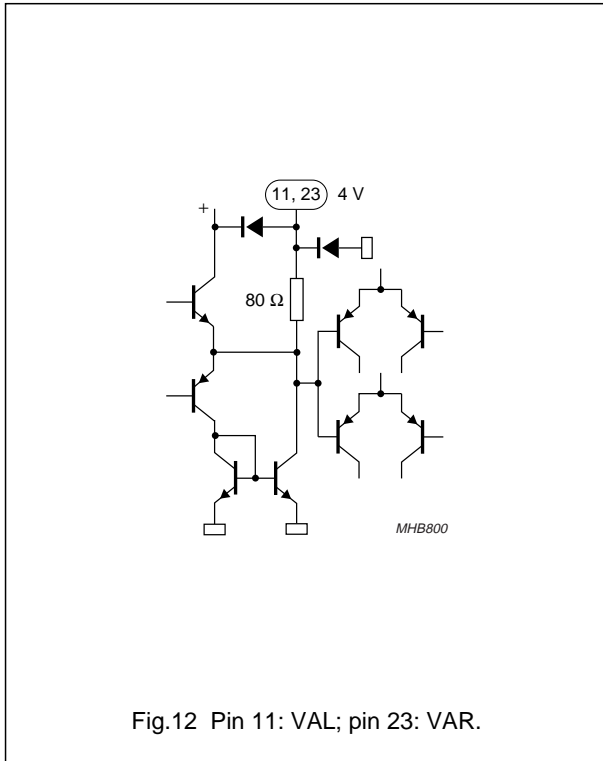

Fig.12 Pin 11: VAL; pin 23: VAR.

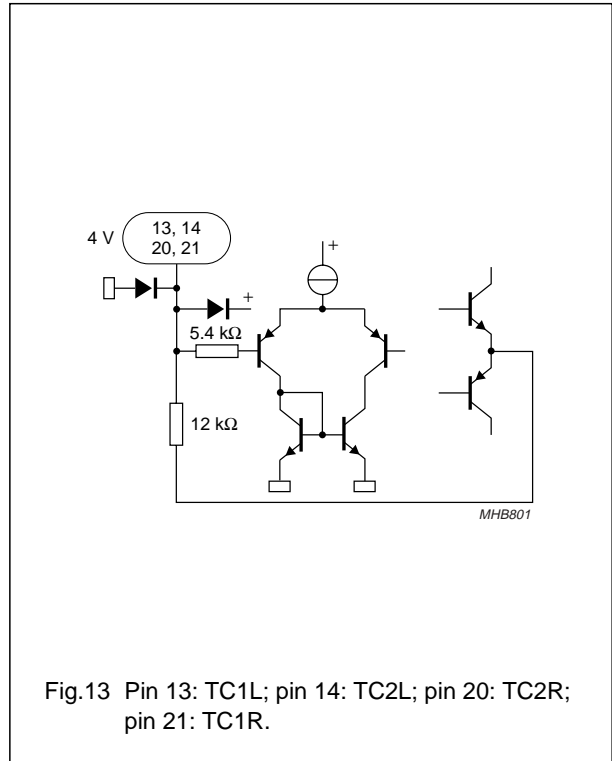
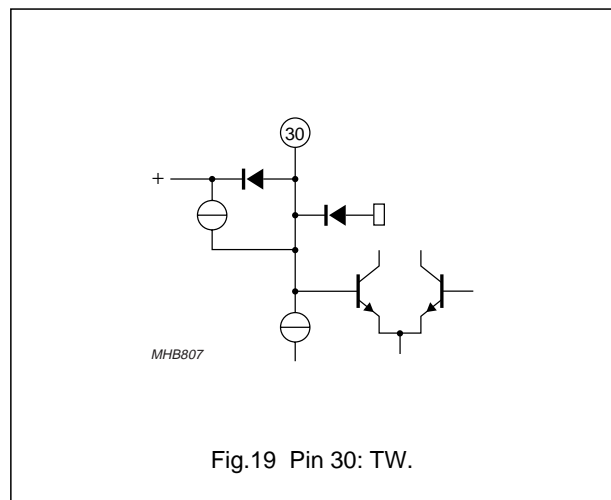
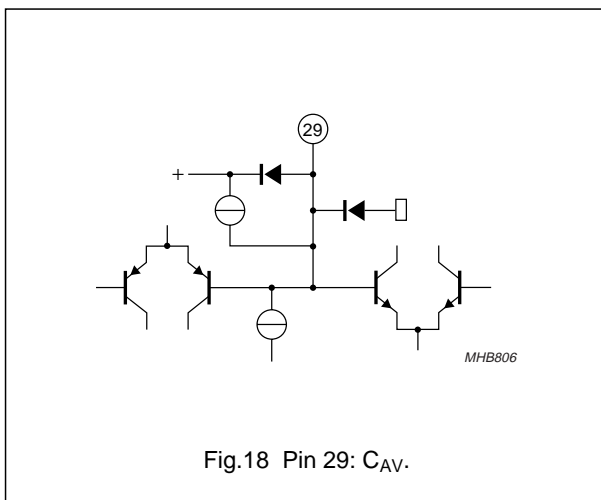
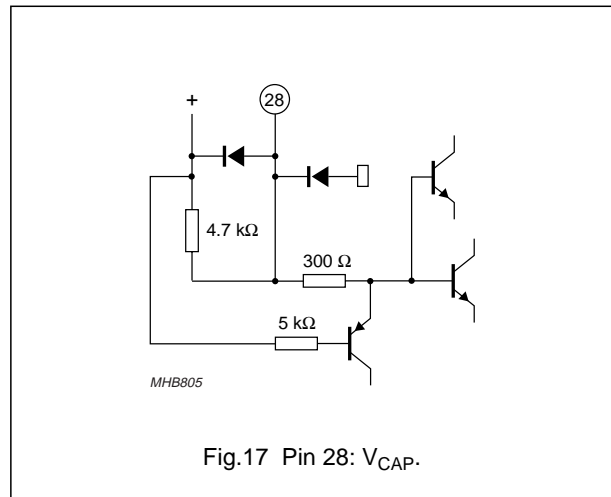
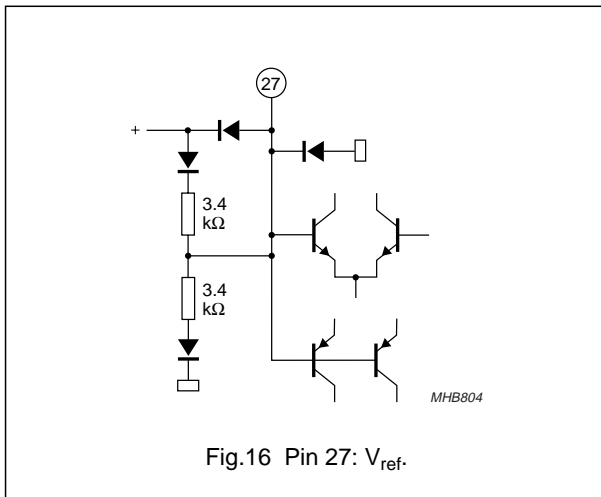
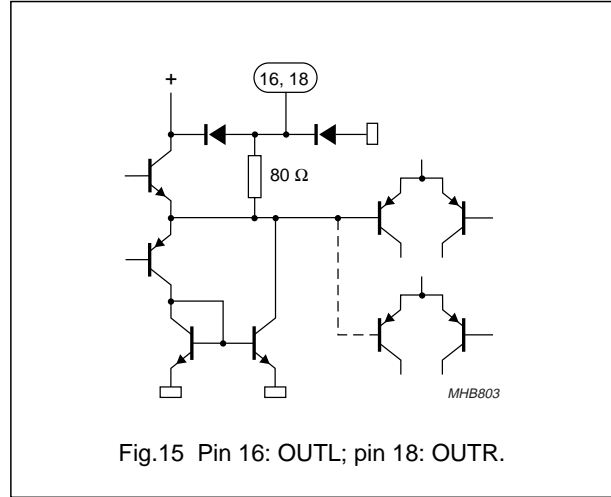
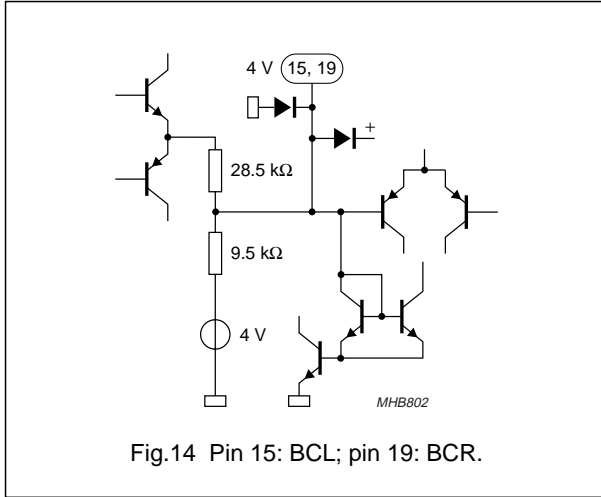

Fig.13 Pin 13: TC1L; pin 14: TC2L; pin 20: TC2R; pin 21: TC1R.

I²C-bus controlled economic BTSC stereo decoder and audio processor

TDA9853H



I²C-bus controlled economic BTSC stereo decoder and audio processor

TDA9853H

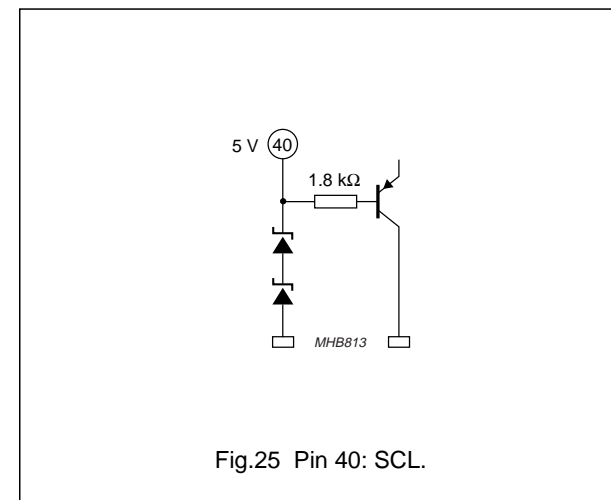
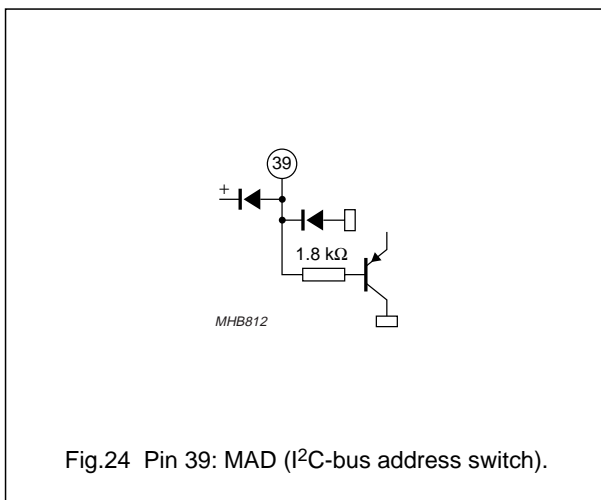
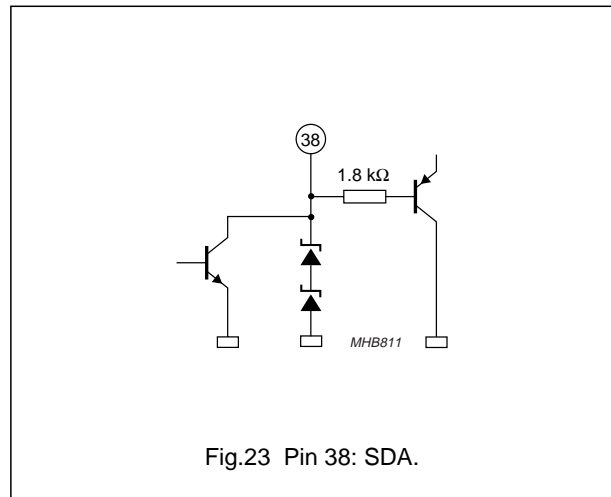
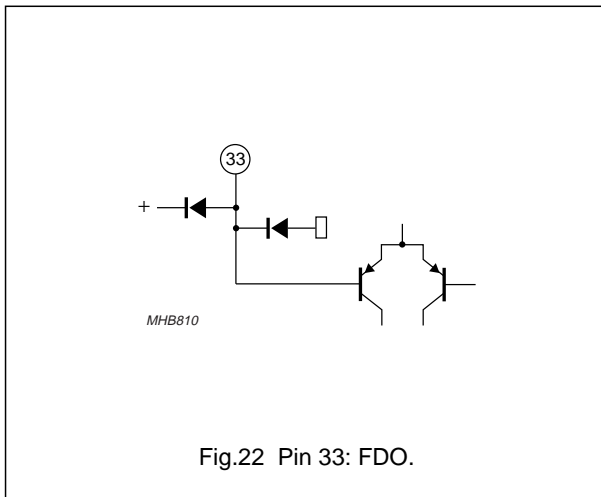
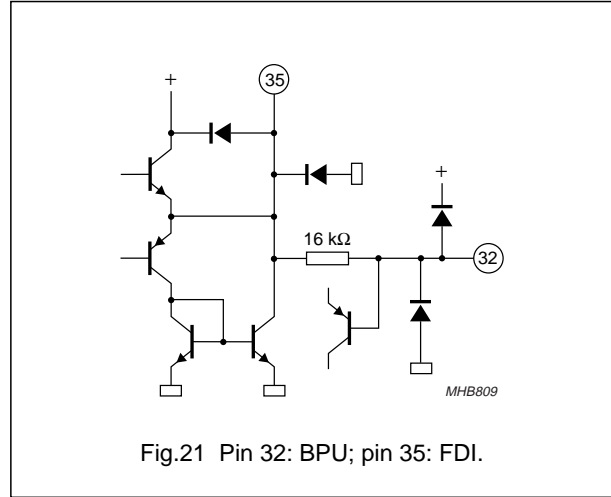
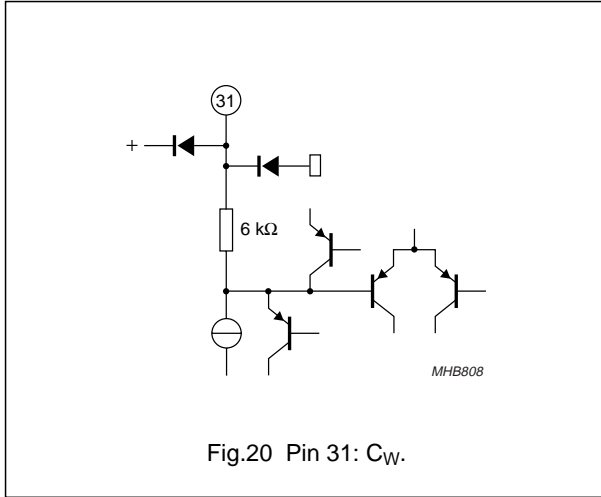

I²C-bus controlled economic BTSC stereo decoder and audio processor

TDA9853H

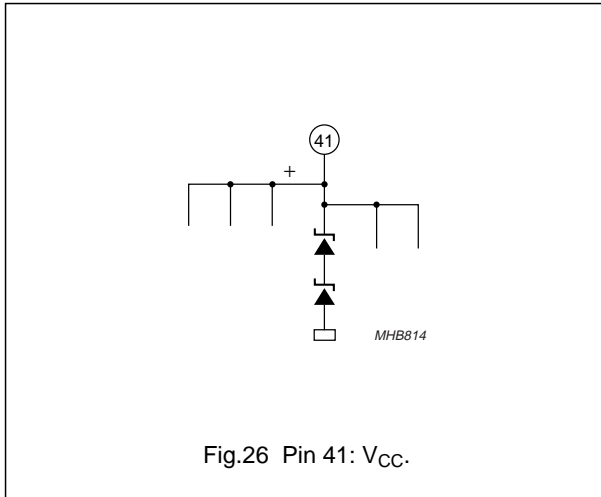

Fig.26 Pin 41: V_{CC}.

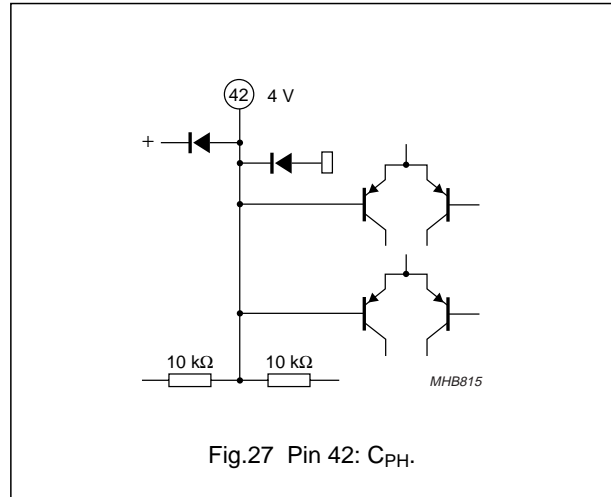

Fig.27 Pin 42: C_{PH}.

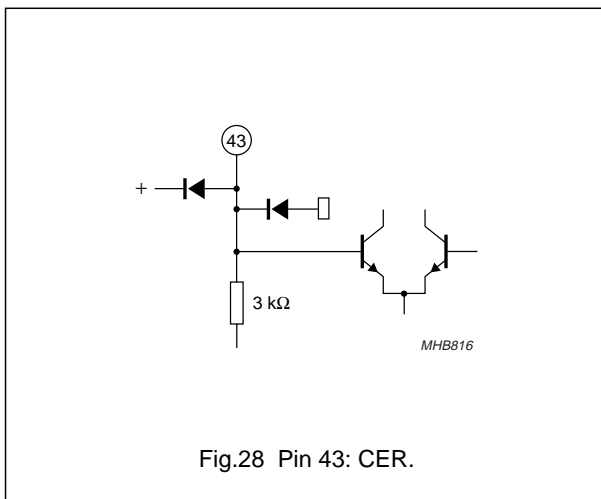

Fig.28 Pin 43: CER.

I²C-bus controlled economic BTSC stereo decoder and audio processor

TDA9853H

PACKAGE OUTLINE

QFP44: plastic quad flat package; 44 leads (lead length 2.35 mm); body 14 x 14 x 2.2 mm

SOT205-1

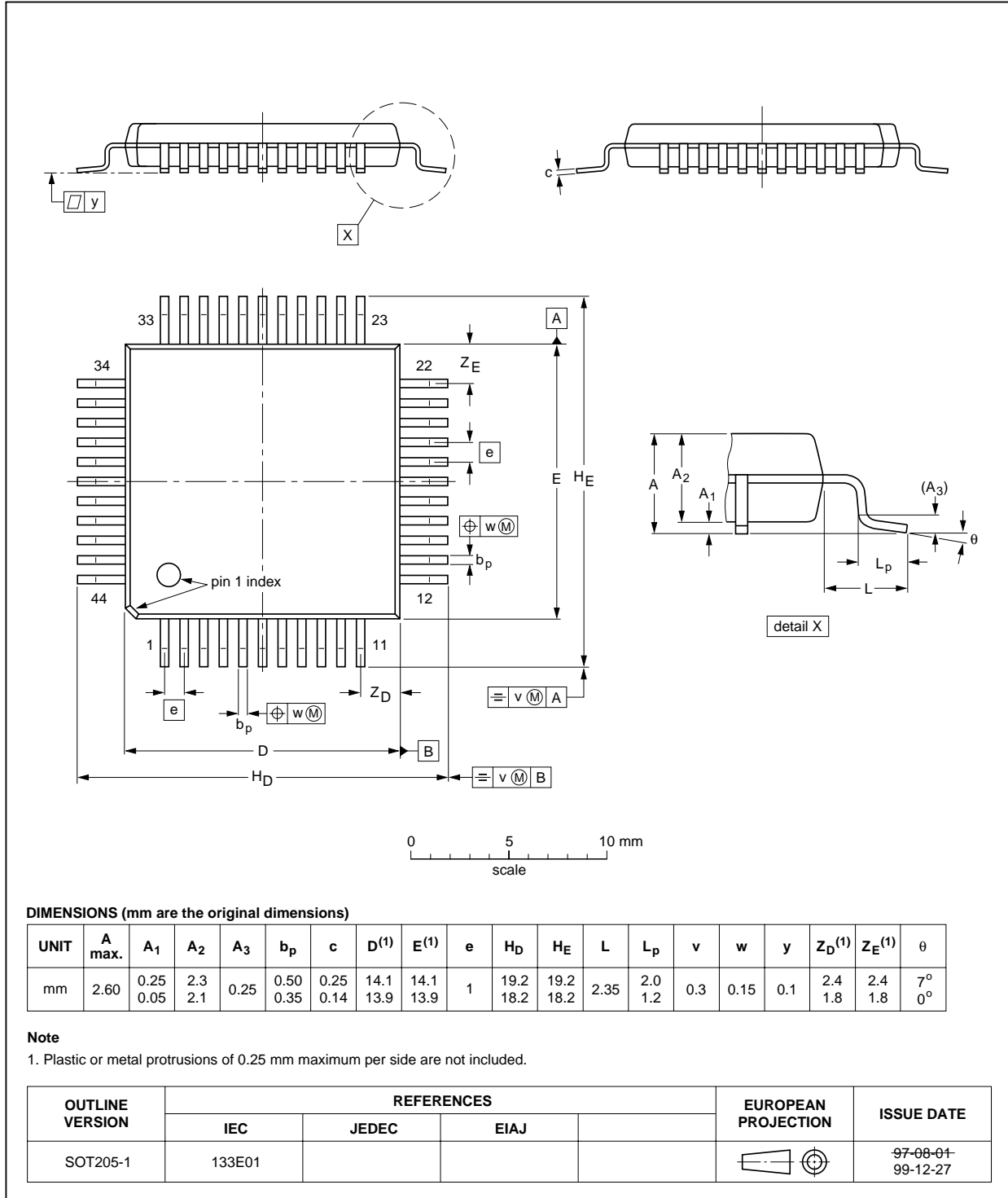

I²C-bus controlled economic BTSC stereo decoder and audio processor

TDA9853H

SOLDERING

Introduction to soldering surface mount packages

This text gives a very brief insight to a complex technology. A more in-depth account of soldering ICs can be found in our "Data Handbook IC26; Integrated Circuit Packages" (document order number 9398 652 90011).

There is no soldering method that is ideal for all surface mount IC packages. Wave soldering can still be used for certain surface mount ICs, but it is not suitable for fine pitch SMDs. In these situations reflow soldering is recommended.

Reflow soldering

Reflow soldering requires solder paste (a suspension of fine solder particles, flux and binding agent) to be applied to the printed-circuit board by screen printing, stencilling or pressure-syringe dispensing before package placement.

Several methods exist for reflowing; for example, convection or convection/infrared heating in a conveyor type oven. Throughput times (preheating, soldering and cooling) vary between 100 and 200 seconds depending on heating method.

Typical reflow peak temperatures range from 215 to 250 °C. The top-surface temperature of the packages should preferably be kept below 220 °C for thick/large packages, and below 235 °C for small/thin packages.

Wave soldering

Conventional single wave soldering is not recommended for surface mount devices (SMDs) or printed-circuit boards with a high component density, as solder bridging and non-wetting can present major problems.

To overcome these problems the double-wave soldering method was specifically developed.

If wave soldering is used the following conditions must be observed for optimal results:

- Use a double-wave soldering method comprising a turbulent wave with high upward pressure followed by a smooth laminar wave.
- For packages with leads on two sides and a pitch (e):
 - larger than or equal to 1.27 mm, the footprint longitudinal axis is **preferred** to be parallel to the transport direction of the printed-circuit board;
 - smaller than 1.27 mm, the footprint longitudinal axis **must** be parallel to the transport direction of the printed-circuit board.

The footprint must incorporate solder thieves at the downstream end.

- For packages with leads on four sides, the footprint must be placed at a 45° angle to the transport direction of the printed-circuit board. The footprint must incorporate solder thieves downstream and at the side corners.

During placement and before soldering, the package must be fixed with a droplet of adhesive. The adhesive can be applied by screen printing, pin transfer or syringe dispensing. The package can be soldered after the adhesive is cured.

Typical dwell time is 4 seconds at 250 °C.

A mildly-activated flux will eliminate the need for removal of corrosive residues in most applications.

Manual soldering

Fix the component by first soldering two diagonally-opposite end leads. Use a low voltage (24 V or less) soldering iron applied to the flat part of the lead. Contact time must be limited to 10 seconds at up to 300 °C.

When using a dedicated tool, all other leads can be soldered in one operation within 2 to 5 seconds between 270 and 320 °C.

I²C-bus controlled economic BTSC stereo decoder and audio processor

TDA9853H

Suitability of surface mount IC packages for wave and reflow soldering methods

PACKAGE	SOLDERING METHOD	
	WAVE	REFLOW ⁽¹⁾
BGA, LFBGA, SQFP, TFBGA	not suitable	suitable
HBCC, HLQFP, HSQFP, HSOP, HTQFP, HTSSOP, SMS	not suitable ⁽²⁾	suitable
PLCC ⁽³⁾ , SO, SOJ	suitable	suitable
LQFP, QFP, TQFP	not recommended ⁽³⁾⁽⁴⁾	suitable
SSOP, TSSOP, VSO	not recommended ⁽⁵⁾	suitable

Notes

1. All surface mount (SMD) packages are moisture sensitive. Depending upon the moisture content, the maximum temperature (with respect to time) and body size of the package, there is a risk that internal or external package cracks may occur due to vaporization of the moisture in them (the so called popcorn effect). For details, refer to the Drypack information in the *"Data Handbook IC26; Integrated Circuit Packages; Section: Packing Methods"*.
2. These packages are not suitable for wave soldering as a solder joint between the printed-circuit board and heatsink (at bottom version) can not be achieved, and as solder may stick to the heatsink (on top version).
3. If wave soldering is considered, then the package must be placed at a 45° angle to the solder wave direction. The package footprint must incorporate solder thieves downstream and at the side corners.
4. Wave soldering is only suitable for LQFP, TQFP and QFP packages with a pitch (e) equal to or larger than 0.8 mm; it is definitely not suitable for packages with a pitch (e) equal to or smaller than 0.65 mm.
5. Wave soldering is only suitable for SSOP and TSSOP packages with a pitch (e) equal to or larger than 0.65 mm; it is definitely not suitable for packages with a pitch (e) equal to or smaller than 0.5 mm.

I²C-bus controlled economic BTSC stereo decoder and audio processor

TDA9853H

DATA SHEET STATUS

DATA SHEET STATUS	PRODUCT STATUS	DEFINITIONS ⁽¹⁾
Objective specification	Development	This data sheet contains the design target or goal specifications for product development. Specification may change in any manner without notice.
Preliminary specification	Qualification	This data sheet contains preliminary data, and supplementary data will be published at a later date. Philips Semiconductors reserves the right to make changes at any time without notice in order to improve design and supply the best possible product.
Product specification	Production	This data sheet contains final specifications. Philips Semiconductors reserves the right to make changes at any time without notice in order to improve design and supply the best possible product.

Note

1. Please consult the most recently issued data sheet before initiating or completing a design.

DEFINITIONS

Short-form specification — The data in a short-form specification is extracted from a full data sheet with the same type number and title. For detailed information see the relevant data sheet or data handbook.

Limiting values definition — Limiting values given are in accordance with the Absolute Maximum Rating System (IEC 60134). Stress above one or more of the limiting values may cause permanent damage to the device. These are stress ratings only and operation of the device at these or at any other conditions above those given in the Characteristics sections of the specification is not implied. Exposure to limiting values for extended periods may affect device reliability.

Application information — Applications that are described herein for any of these products are for illustrative purposes only. Philips Semiconductors make no representation or warranty that such applications will be suitable for the specified use without further testing or modification.

DISCLAIMERS

Life support applications — These products are not designed for use in life support appliances, devices, or systems where malfunction of these products can reasonably be expected to result in personal injury. Philips Semiconductors customers using or selling these products for use in such applications do so at their own risk and agree to fully indemnify Philips Semiconductors for any damages resulting from such application.

Right to make changes — Philips Semiconductors reserves the right to make changes, without notice, in the products, including circuits, standard cells, and/or software, described or contained herein in order to improve design and/or performance. Philips Semiconductors assumes no responsibility or liability for the use of any of these products, conveys no licence or title under any patent, copyright, or mask work right to these products, and makes no representations or warranties that these products are free from patent, copyright, or mask work right infringement, unless otherwise specified.

PURCHASE OF PHILIPS I²C COMPONENTS



Purchase of Philips I²C components conveys a license under the Philips' I²C patent to use the components in the I²C system provided the system conforms to the I²C specification defined by Philips. This specification can be ordered using the code 9398 393 40011.

Philips Semiconductors – a worldwide company

Argentina: see South America

Australia: 3 Figtree Drive, HOMEBUSH, NSW 2140,
Tel. +61 2 9704 8141, Fax. +61 2 9704 8139

Austria: Computerstr. 6, A-1101 WIEN, P.O. Box 213,
Tel. +43 1 60 101 1248, Fax. +43 1 60 101 1210

Belarus: Hotel Minsk Business Center, Bld. 3, r. 1211, Volodarski Str. 6,
220050 MINSK, Tel. +375 172 20 0733, Fax. +375 172 20 0773

Belgium: see The Netherlands

Brazil: see South America

Bulgaria: Philips Bulgaria Ltd., Energoproject, 15th floor,
51 James Bourchier Blvd., 1407 SOFIA,
Tel. +359 2 68 9211, Fax. +359 2 68 9102

Canada: PHILIPS SEMICONDUCTORS/COMPONENTS,
Tel. +1 800 234 7381, Fax. +1 800 943 0087

China/Hong Kong: 501 Hong Kong Industrial Technology Centre,
72 Tat Chee Avenue, Kowloon Tong, HONG KONG,
Tel. +852 2319 7888, Fax. +852 2319 7700

Colombia: see South America

Czech Republic: see Austria

Denmark: Sydhavnsgade 23, 1780 COPENHAGEN V,
Tel. +45 33 29 3333, Fax. +45 33 29 3905

Finland: Sinikalliontie 3, FIN-02630 ESPOO,
Tel. +358 9 615 800, Fax. +358 9 6158 0920

France: 51 Rue Carnot, BP317, 92156 SURESNES Cedex,
Tel. +33 1 4099 6161, Fax. +33 1 4099 6427

Germany: Hammerbrookstraße 69, D-20097 HAMBURG,
Tel. +49 40 2353 60, Fax. +49 40 2353 6300

Hungary: see Austria

India: Philips INDIA Ltd, Band Box Building, 2nd floor,
254-D, Dr. Annie Besant Road, Worli, MUMBAI 400 025,
Tel. +91 22 493 8541, Fax. +91 22 493 0966

Indonesia: PT Philips Development Corporation, Semiconductors Division,
Gedung Philips, Jl. Buncit Raya Kav.99-100, JAKARTA 12510,
Tel. +62 21 794 0040 ext. 2501, Fax. +62 21 794 0080

Ireland: Newstead, Clonskeagh, DUBLIN 14,
Tel. +353 1 7640 000, Fax. +353 1 7640 200

Israel: RAPAC Electronics, 7 Kehilat Saloniki St, PO Box 18053,
TEL AVIV 61180, Tel. +972 3 645 0444, Fax. +972 3 649 1007

Italy: PHILIPS SEMICONDUCTORS, Via Casati, 23 - 20052 MONZA (MI),
Tel. +39 039 203 6838, Fax +39 039 203 6800

Japan: Philips Bldg 13-37, Kohnan 2-chome, Minato-ku,
TOKYO 108-8507, Tel. +81 3 3740 5130, Fax. +81 3 3740 5057

Korea: Philips House, 260-199 Itaewon-dong, Yongsan-ku, SEOUL,
Tel. +82 2 709 1412, Fax. +82 2 709 1415

Malaysia: No. 76 Jalan Universiti, 46200 PETALING JAYA, SELANGOR,
Tel. +60 3 750 5214, Fax. +60 3 757 4880

Mexico: 5900 Gateway East, Suite 200, EL PASO, TEXAS 79905,
Tel. +9-5 800 234 7381, Fax +9-5 800 943 0087

Middle East: see Italy

Netherlands: Postbus 90050, 5600 PB EINDHOVEN, Bldg. VB,
Tel. +31 40 27 82785, Fax. +31 40 27 88399

New Zealand: 2 Wagener Place, C.P.O. Box 1041, AUCKLAND,
Tel. +64 9 849 4160, Fax. +64 9 849 7811

Norway: Box 1, Manglerud 0612, OSLO,
Tel. +47 22 74 8000, Fax. +47 22 74 8341

Pakistan: see Singapore

Philippines: Philips Semiconductors Philippines Inc.,
106 Valero St. Salcedo Village, P.O. Box 2108 MCC, MAKATI,
Metro MANILA, Tel. +63 2 816 6380, Fax. +63 2 817 3474

Poland: Al.Jerozolimskie 195 B, 02-222 WARSAW,
Tel. +48 22 5710 000, Fax. +48 22 5710 001

Portugal: see Spain

Romania: see Italy

Russia: Philips Russia, Ul. Usatcheva 35A, 119048 MOSCOW,
Tel. +7 095 755 6918, Fax. +7 095 755 6919

Singapore: Lorong 1, Toa Payoh, SINGAPORE 319762,
Tel. +65 350 2538, Fax. +65 251 6500

Slovakia: see Austria

Slovenia: see Italy

South Africa: S.A. PHILIPS Pty Ltd., 195-215 Main Road Martindale,
2092 JOHANNESBURG, P.O. Box 58088 Newville 2114,
Tel. +27 11 471 5401, Fax. +27 11 471 5398

South America: Al. Vicente Pinzon, 173, 6th floor,
04547-130 SÃO PAULO, SP, Brazil,
Tel. +55 11 821 2333, Fax. +55 11 821 2382

Spain: Balmes 22, 08007 BARCELONA,
Tel. +34 93 301 6312, Fax. +34 93 301 4107

Sweden: Kottbygatan 7, Akalla, S-16485 STOCKHOLM,
Tel. +46 8 5985 2000, Fax. +46 8 5985 2745

Switzerland: Allmendstrasse 140, CH-8027 ZÜRICH,
Tel. +41 1 488 2741 Fax. +41 1 488 3263

Taiwan: Philips Semiconductors, 5F, No. 96, Chien Kuo N. Rd., Sec. 1,
TAIPEI, Taiwan Tel. +886 2 2134 2451, Fax. +886 2 2134 2874

Thailand: PHILIPS ELECTRONICS (THAILAND) Ltd.,
60/14 MOO 11, Bangna Trad Road KM. 3, Bagna, BANGKOK 10260,
Tel. +66 2 361 7910, Fax. +66 2 398 3447

Turkey: Yukari Dudullu, Org. San. Blg., 2.Cad. Nr. 28 81260 Umraniye,
ISTANBUL, Tel. +90 216 522 1500, Fax. +90 216 522 1813

Ukraine: PHILIPS UKRAINE, 4 Patrice Lumumba str., Building B, Floor 7,
252042 KIEV, Tel. +380 44 264 2776, Fax. +380 44 268 0461

United Kingdom: Philips Semiconductors Ltd., 276 Bath Road, Hayes,
MIDDLESEX UB3 5BX, Tel. +44 208 730 5000, Fax. +44 208 754 8421

United States: 811 East Arques Avenue, SUNNYVALE, CA 94088-3409,
Tel. +1 800 234 7381, Fax. +1 800 943 0087

Uruguay: see South America

Vietnam: see Singapore

Yugoslavia: PHILIPS, Trg N. Pasica 5/v, 11000 BEOGRAD,
Tel. +381 11 3341 299, Fax.+381 11 3342 553

For all other countries apply to: Philips Semiconductors,
Marketing Communications, Building BE-p, P.O. Box 218, 5600 MD EINDHOVEN,
The Netherlands, Fax. +31 40 27 24825

Internet: <http://www.semiconductors.philips.com>

© Philips Electronics N.V. 2000

SCA 70

All rights are reserved. Reproduction in whole or in part is prohibited without the prior written consent of the copyright owner.

The information presented in this document does not form part of any quotation or contract, is believed to be accurate and reliable and may be changed without notice. No liability will be accepted by the publisher for any consequence of its use. Publication thereof does not convey nor imply any license under patent- or other industrial or intellectual property rights.

Printed in The Netherlands

753504/01/pp28

Date of release: 2000 Dec 11

Document order number: 9397 750 07474

Let's make things better.

**Philips
Semiconductors**



PHILIPS