



THE INFINITE POWER OF INNOVATION

TL431/TL431A/TL431B**PRECISION PROGRAMMABLE REFERENCES****PRODUCTION DATA SHEET****DESCRIPTION**

The TL431/TL431A/TL431B series precision adjustable three terminal shunt voltage regulators are pin-to-pin compatible with the industry standard TL431. The output voltage of this reference is programmable by using two external resistors from 2.5V to 36V.

These devices offer low output

impedance for improved load regulation. The typical output impedance of these devices is 200mΩ. These devices find application in the feedback path of switching power supplies, OVP crowbar circuits, reference for A/D, D/A, and as zener diodes with improved turn-on characteristics.

NOTE: For current data & package dimensions, visit our web site: <http://www.linfinity.com>.

KEY FEATURES

- INITIAL VOLTAGE REFERENCE ACCURACY OF 0.4% (TL431B)
- SINK CURRENT CAPABILITY 1mA to 100mA
- TYPICAL OUTPUT DYNAMIC IMPEDANCE LESS THAN 200mΩ;
- TYPICAL OUTPUT IMPEDANCE OF THE TL431B LESS THAN 100mΩ
- ADJUSTABLE OUTPUT VOLTAGE FROM 2.5V TO 36V
- AVAILABLE IN SURFACE-MOUNT PACKAGES
- LOW OUTPUT NOISE
- TYPICAL EQUIVALENT FULL RANGE TEMPERATURE COEFFICIENT OF 30ppm/°C
- DIRECT PIN-TO-PIN REPLACEMENT FOR INDUSTRY STANDARD TL431 AND TL1431

PRODUCT HIGHLIGHT

PRECISION PROGRAMMABLE REFERENCES

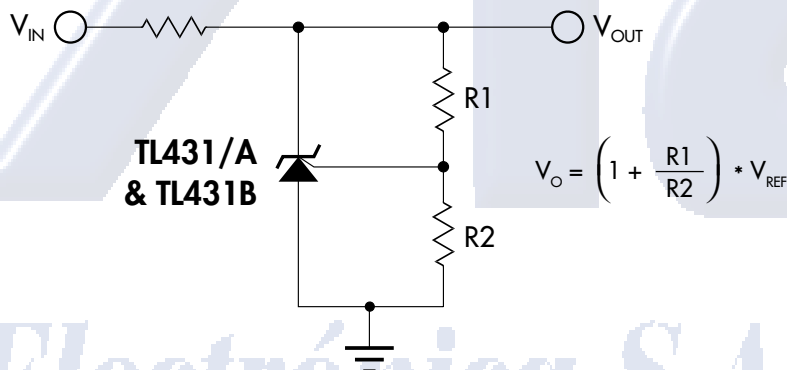

Electrónica S.A. de C.V.

PACKAGE ORDER INFORMATION

T _A (°C)	Initial Tolerance	DM	LP
		Plastic SOIC 8-pin	Plastic TO-92 3-pin
0 to 70	2%	TL431CDM	TL431CLP
	1%	TL431ACDM	TL431ACLP
	0.4%	TL431BCDM	TL431BCLP
-40 to 85	2%	TL431IDM	TL431ILP
	1%	TL431AIDM	TL431AILP
	0.4%	TL431BIDM	TL431BILP

Note: All surface-mount packages are available in Tape & Reel.

Append the letter "T" to part number. (i.e. TL431CDMT)

TO-92 (LP) package also available in ammo-pack.

LINFINITY MICROELECTRONICS INC.

11861 WESTERN AVENUE, GARDEN GROVE, CA. 92841, 714-898-8121, FAX: 714-893-2570

TL431/TL431A/TL431B

PRECISION PROGRAMMABLE REFERENCES

PRODUCTION DATA SHEET

ABSOLUTE MAXIMUM RATINGS (Note 1)

Cathode to Anode Voltage (V_{KA}) (Note 2)	-0.3V to 37V
Reference Input Current (I_{REF})	-50 μ A to 10mA
Continuous Cathode Current (I_K)	-100mA to 150mA
Operating Junction Temperature	
Plastic (DM, LP Packages)	150°C
Storage Temperature Range	-65°C to 150°C
Lead Temperature	300°C

Note 1. Exceeding these ratings could cause damage to the device. All voltages are with respect to Ground. Currents are positive into, negative out of the specified terminal. Pin numbers refer to DIL packages only.

Note 2. Voltage values are with respect to the anode terminal unless otherwise noted.

THERMAL DATA

DM PACKAGE:

THERMAL RESISTANCE-JUNCTION TO AMBIENT, θ_{JA}	165°C/W
---	---------

LP PACKAGE:

THERMAL RESISTANCE-JUNCTION TO AMBIENT, θ_{JA}	156°C/W
---	---------

Junction Temperature Calculation: $T_J = T_A + (P_D \times \theta_{JA})$.

The θ_{JA} numbers are guidelines for the thermal performance of the device/pc-board system.

All of the above assume no ambient airflow

PACKAGE PIN OUTS

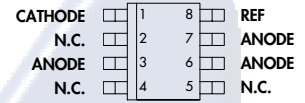

DM PACKAGE (Top View)

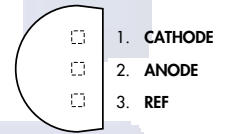

LP PACKAGE (Top View)

BLOCK DIAGRAM

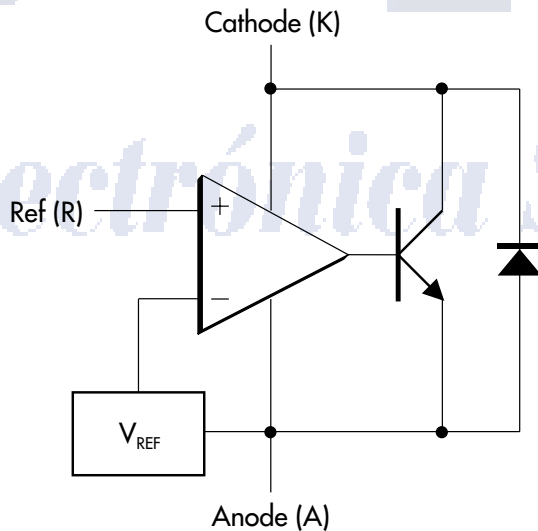

TL431/TL431A/TL431B

PRECISION PROGRAMMABLE REFERENCES

PRODUCTION DATA SHEET

ELECTRICAL CHARACTERISTICS (Note 3)

(Unless otherwise specified, these specifications apply over the operating ambient temperatures for TL431C/TL431AC/TL431BC with $0^{\circ}\text{C} \leq T_A \leq 70^{\circ}\text{C}$, TL431I/TL431AI/TL431BI with $-40^{\circ}\text{C} \leq T_A \leq 85^{\circ}\text{C}$.)

Parameter	Symbol	Test Conditions	TL431/431A/431B			Units	
			Min.	Typ.	Max.		
Reference Input Voltage	TL431	$I_K = 10\text{mA}, V_{KA} = V_{REF}, T_A = 25^{\circ}\text{C}$	2440	2495	2550	mV	
	TL431A		2470	2495	2520	mV	
	TL431B		2490	2500	2510	mV	
Reference Drift	TL431C	$I_K = 10\text{mA}, V_{KA} = V_{REF}$		4	17	mV	
	TL431I			5	30	mV	
	TL431AC		$\frac{\Delta V_{REF}}{\Delta V_{KA}}$		4	17	mV
	TL431AI				5	30	mV
	TL431BC		$I_K = 10\text{mA}, V_{KA} = V_{REF}$		4	15	mV
	TL431BI				5	20	mV
	Voltage Ratio, Ref to Cathode (Note 4)		TL431, TL431A	$I_K = 10\text{mA}, V_{KA} = 2.5\text{V to } 36\text{V}$		-1.4	-2.7
TL431B		$I_K = 10\text{mA}, V_{KA} = 2.5\text{V to } 36\text{V}$		-1.1	-2	mV/V	
Reference Input Current	TL431, TL431A	$V_{KA} = V_{REF}, T_A = 25^{\circ}\text{C}$		2	4	μA	
	TL431B		$V_{KA} = V_{REF}, T_A = 25^{\circ}\text{C}$	1.5	1.9	μA	
			$V_{KA} = V_{REF}, T_A = \text{Operating Range}$			2.3	μA
Minimum Operating Current	I_{MIN}	$V_{KA} = V_{REF}$ to 36V		0.4	1	mA	
Off-State Cathode Current	TL431	I_{OFF}	$V_{KA} = V_{REF}$ to 36V, $T_A = 25^{\circ}\text{C}$	0.1	1	μA	
	TL431A			0.1	1	μA	
	TL431B		$V_{KA} = V_{REF}$ to 36V, $T_A = \text{Operating Range}$			2	μA
			$V_{KA} = 36\text{V}, V_{REF} = 0\text{V}, T_A = 25^{\circ}\text{C}$	0.18	0.5	μA	
			$V_{KA} = 36\text{V}, V_{REF} = 0\text{V}, T_A = \text{Operating Range}$				
Dynamic Impedance	TL431	$ Z_{KA} $	$V_{KA} = V_{REF}, I_K = 1\text{mA to } 100\text{mA}, f \leq 1\text{kHz}, T_A = 25^{\circ}\text{C}$	0.2	0.5	Ω	
	TL431B			0.1	0.2	Ω	

Note 3. These parameters are guaranteed by design.

Note 4. $\frac{\Delta V_{REF}}{\Delta V_{KA}}$ Ratio of change in reference input voltage to the change in cathode voltage.

Electrónica S.A. de C.V.

TL431/TL431A/TL431B**PRECISION PROGRAMMABLE REFERENCES****PRODUCTION DATA SHEET****GRAPH / CURVE INDEX****Characteristic Curves****FIGURE #**

1. REFERENCE INPUT VOLTAGE vs. FREE-AIR TEMPERATURE
2. REFERENCE INPUT CURRENT vs. FREE-AIR TEMPERATURE
3. CATHODE CURRENT vs. CATHODE VOLTAGE
4. CATHODE CURRENT vs. CATHODE VOLTAGE
5. OFF-STATE CATHODE CURRENT vs. FREE-AIR TEMPERATURE
6. RATIO OF DELTA REFERENCE VOLTAGE TO DELTA CATHODE VOLTAGE vs. FREE-AIR TEMPERATURE
7. EQUIVALENT INPUT NOISE VOLTAGE vs. FREQUENCY

FIGURE INDEX**Parameter Measurement Information****FIGURE #**

8. TEST CIRCUIT FOR $V_{KA} = V_{REF}$
9. TEST CIRCUIT FOR $V_{KA} > V_{REF}$
10. TEST CIRCUIT FOR I_{OFF}

Typical Characteristics**FIGURE #**

11. EQUIVALENT INPUT NOISE VOLTAGE OVER A 10-SECOND PERIOD
12. SMALL-SIGNAL VOLTAGE AMPLIFICATION vs. FREQUENCY
13. REFERENCE IMPEDANCE vs. FREQUENCY
14. PULSE RESPONSE
15. STABILITY BOUNDARY CONDITIONS

Application Information**FIGURE #**

16. SHUNT REGULATOR
17. SINGLE-SUPPLY COMPARATOR WITH TEMPERATURE-COMPENSATED THRESHOLD
18. HIGH CURRENT SHUNT REGULATOR
19. CROWBAR CIRCUIT
20. VOLTAGE MONITOR
21. PRECISION CONSTANT-CURRENT SINK

Electrónica S.A. de C.V.

TL431/TL431A/TL431B

PRECISION PROGRAMMABLE REFERENCES

PRODUCTION DATA SHEET

CHARACTERISTIC CURVES

FIGURE 1. — REFERENCE VOLTAGE vs. FREE-AIR TEMPERATURE

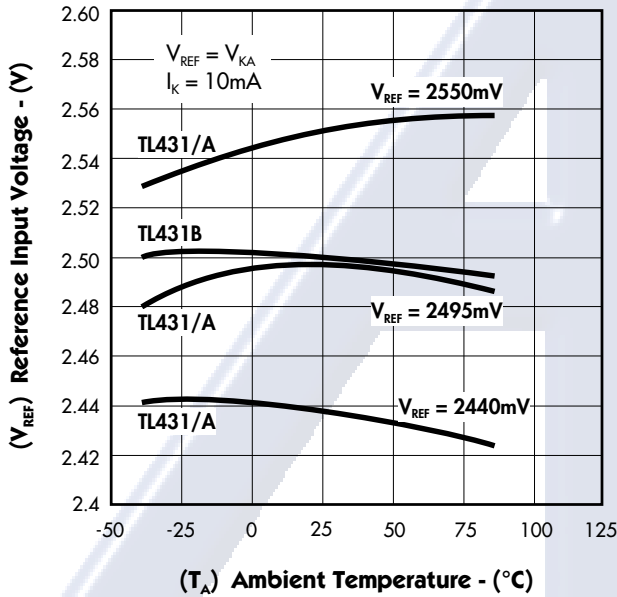

FIGURE 2. — REFERENCE CURRENT vs. FREE-AIR TEMPERATURE

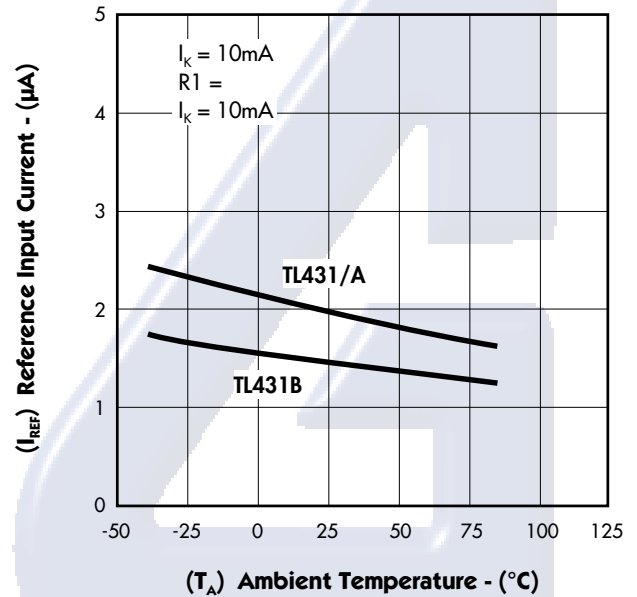

FIGURE 3. — CATHODE CURRENT vs. CATHODE VOLTAGE

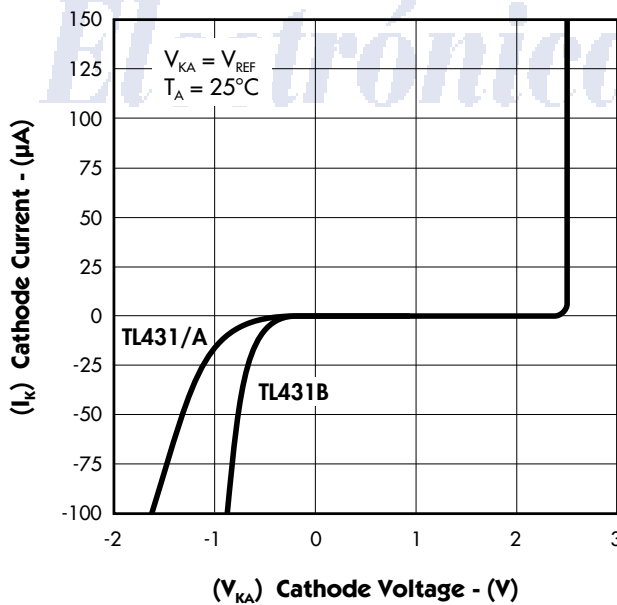
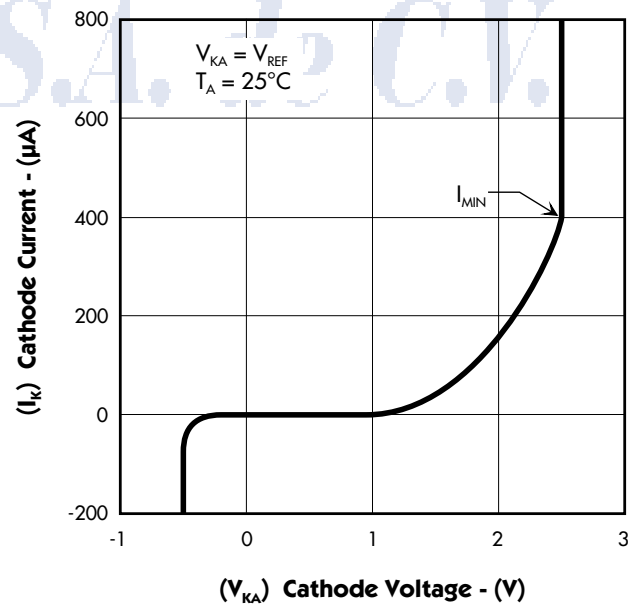

FIGURE 4. — CATHODE CURRENT vs. CATHODE VOLTAGE



TL431/TL431A/TL431B

PRECISION PROGRAMMABLE REFERENCES

PRODUCTION DATA SHEET

CHARACTERISTIC CURVES

FIGURE 5. — OFF-STATE CATHODE CURRENT vs. FREE-AIR TEMPERATURE

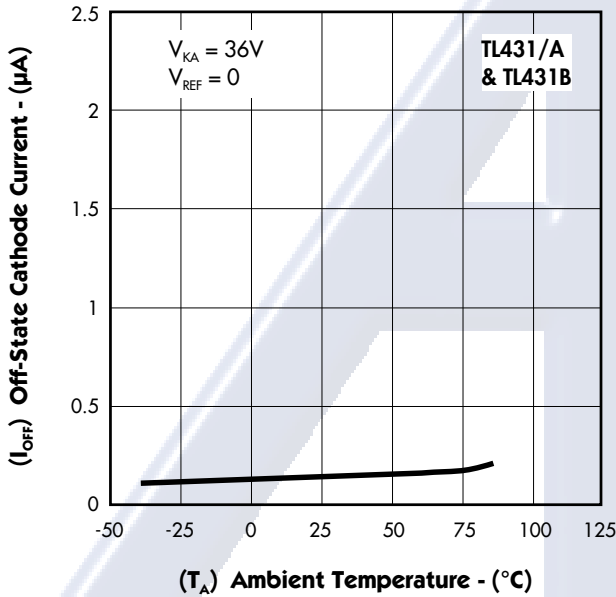

FIGURE 6. — RATIO OF DELTA REFERENCE VOLTAGE TO DELTA CATHODE VOLTAGE vs. FREE-AIR TEMPERATURE

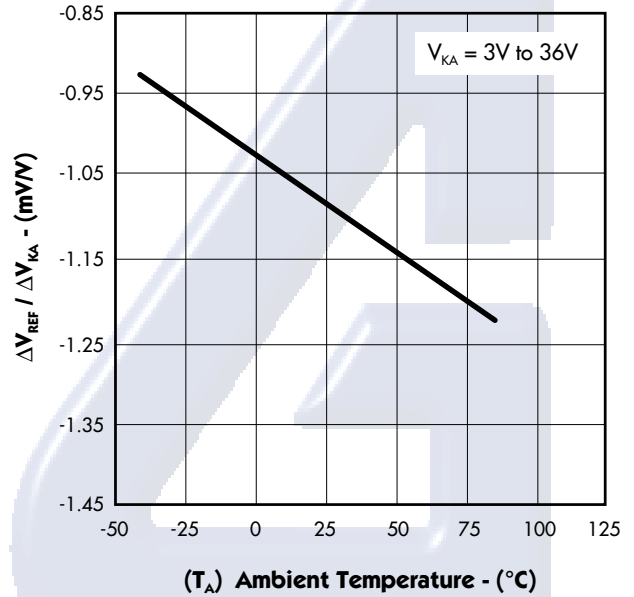
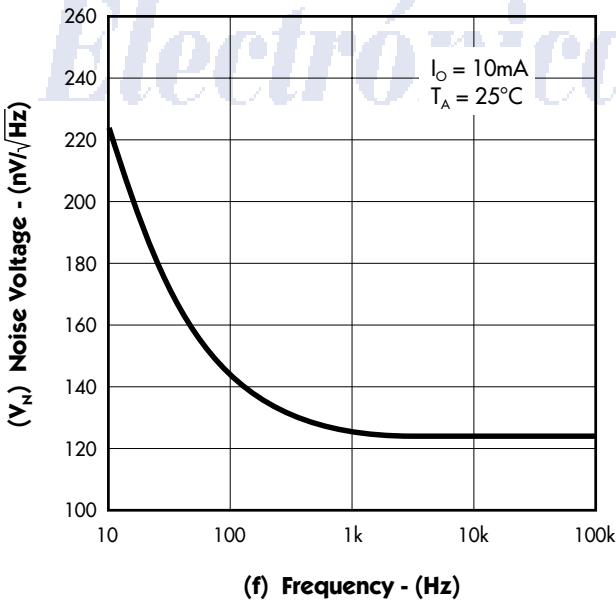
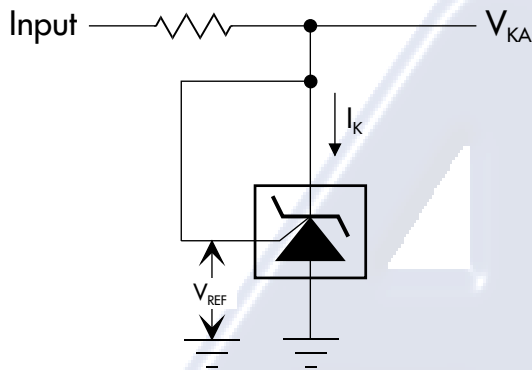
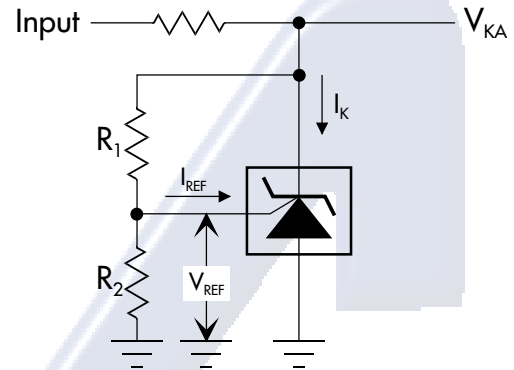
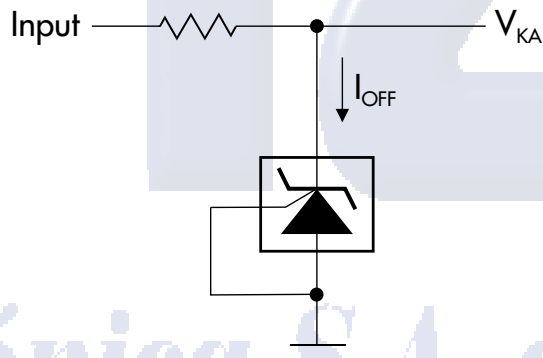

FIGURE 7. — EQUIVALENT INPUT NOISE VOLTAGE vs. FREQUENCY



TL431/TL431A/TL431B**PRECISION PROGRAMMABLE REFERENCES****PRODUCTION DATA SHEET****PARAMETER MEASUREMENT INFORMATION****FIGURE 8** — TEST CIRCUIT FOR $V_{KA} = V_{REF}$ **FIGURE 9** — TEST CIRCUIT FOR $V_{KA} > V_{REF}$ **FIGURE 10** — TEST CIRCUIT FOR I_{OFF} *Electrónica S.A. de C.V.*

TL431/TL431A/TL431B

PRECISION PROGRAMMABLE REFERENCES

PRODUCTION DATA SHEET

TYPICAL CHARACTERISTICS

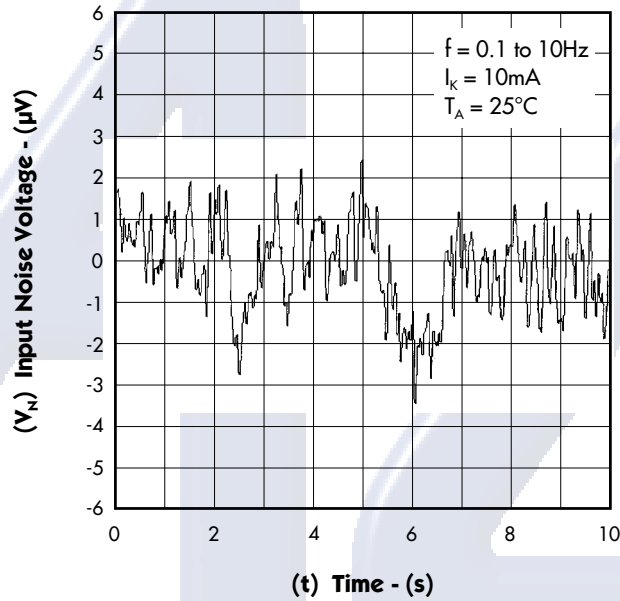
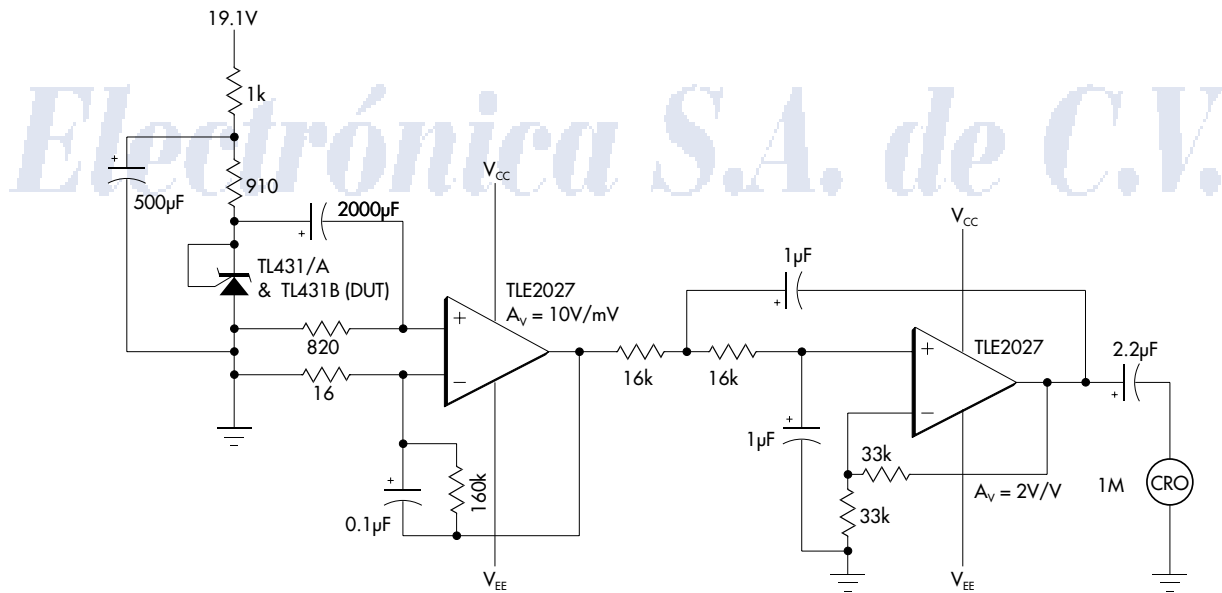

FIGURE 11. — EQUIVALENT INPUT NOISE VOLTAGE OVER A 10-SECOND PERIOD



Test Circuit for 0.1Hz to 10Hz Equivalent Input Noise Voltage

TL431/TL431A/TL431B

PRECISION PROGRAMMABLE REFERENCES

PRODUCTION DATA SHEET

TYPICAL CHARACTERISTICS

FIGURE 12. — SMALL-SIGNAL VOLTAGE AMPLIFICATION vs. FREQUENCY

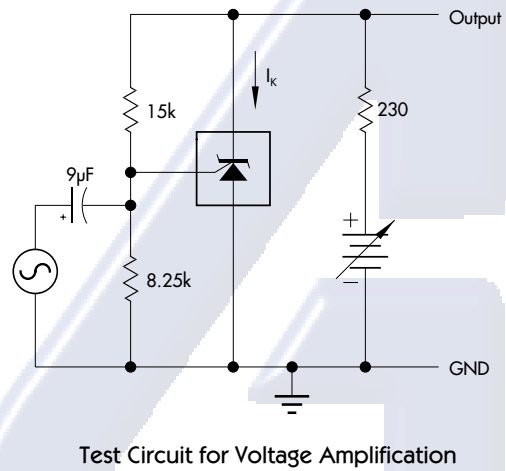
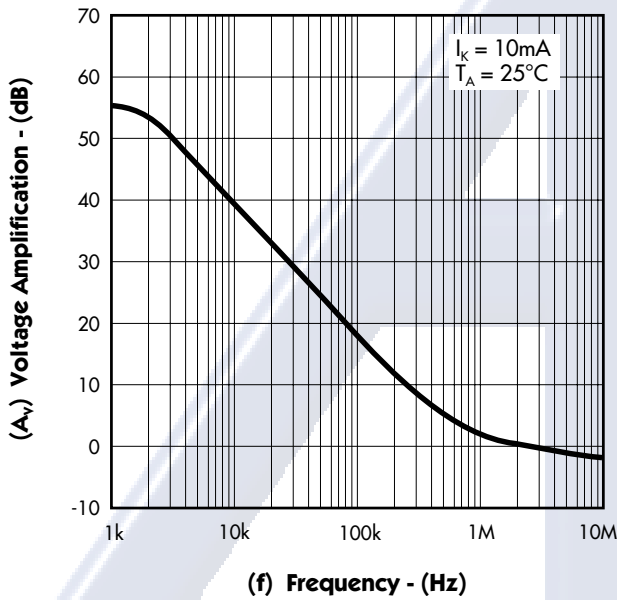
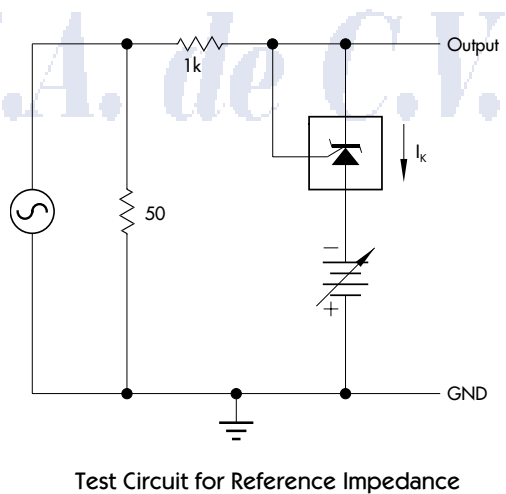
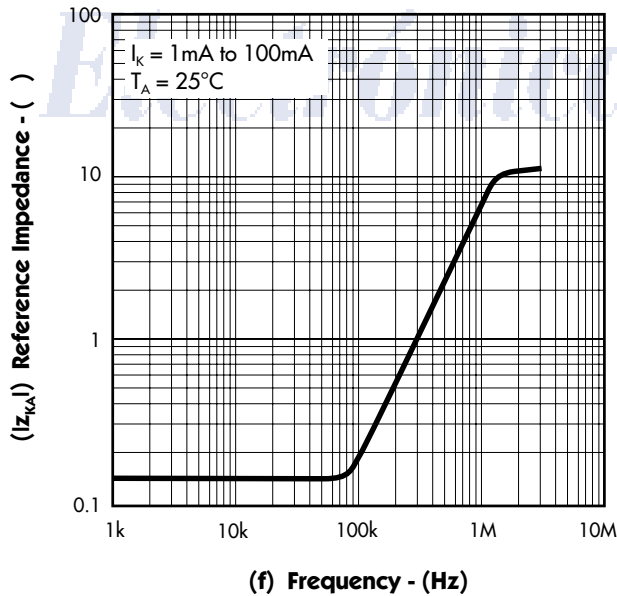

FIGURE 13. — REFERENCE IMPEDANCE vs. FREQUENCY



TL431/TL431A/TL431B

PRECISION PROGRAMMABLE REFERENCES

PRODUCTION DATA SHEET

TYPICAL CHARACTERISTICS

FIGURE 14. — PULSE RESPONSE

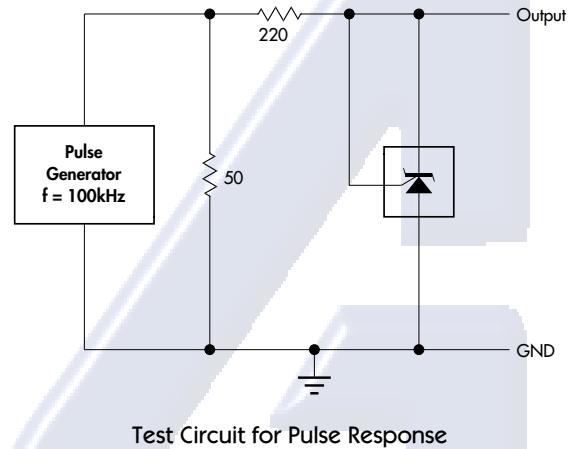
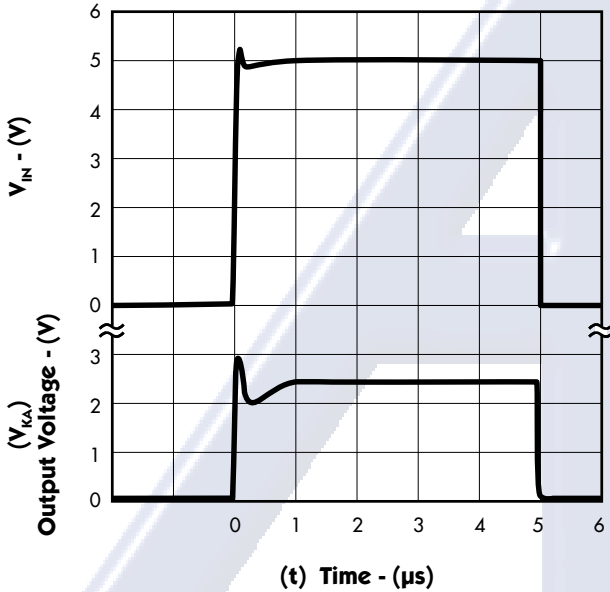
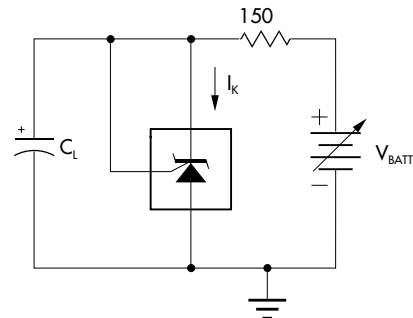
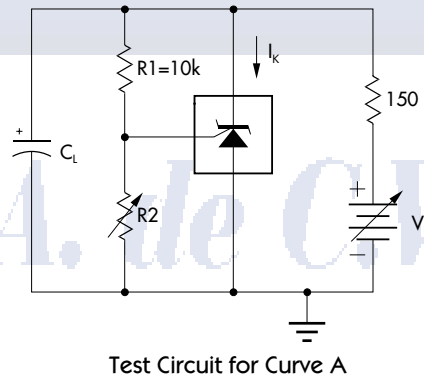
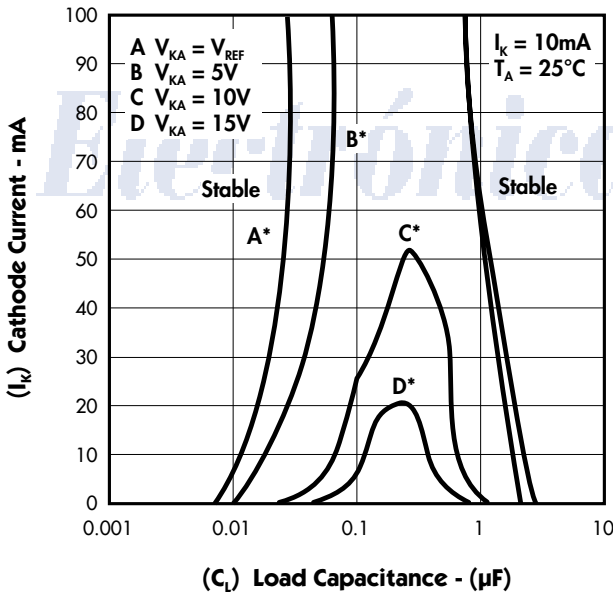

FIGURE 15. — STABILITY BOUNDARY CONDITIONS



* The areas under the curves represent conditions that may cause the device to oscillate. For curves B, C, and D, R_2 and $V+$ were adjusted to establish the initial V_{KA} and I_K conditions with $C_L = 0$. V_{BATT} and C_L were then adjusted to determine the ranges of stability.

TL431/TL431A/TL431B

PRECISION PROGRAMMABLE REFERENCES

PRODUCTION DATA SHEET

APPLICATION INFORMATION

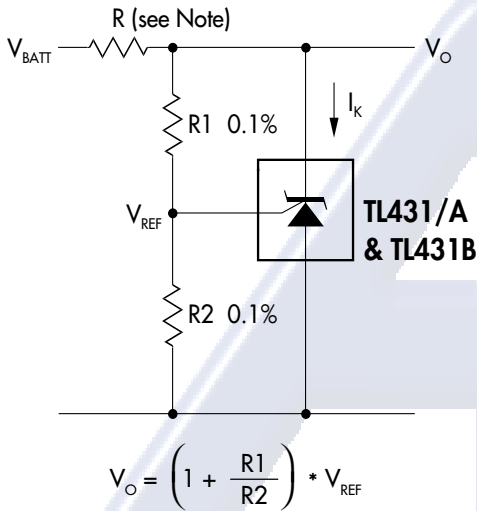

$$V_o = \left(1 + \frac{R1}{R2}\right) * V_{REF}$$

Note: R should provide $\geq 1\text{mA}$ cathode current to the TL431/A & TL431B at minimum V_{BATT} .

FIGURE 16 — SHUNT REGULATOR

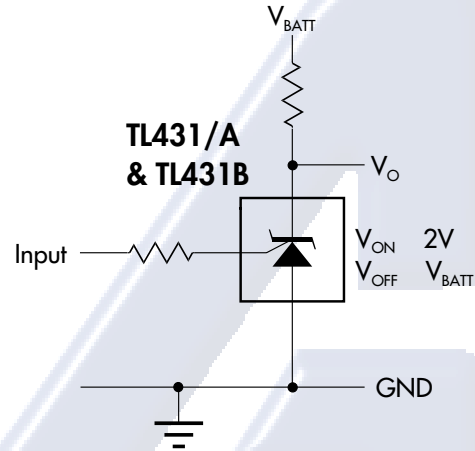
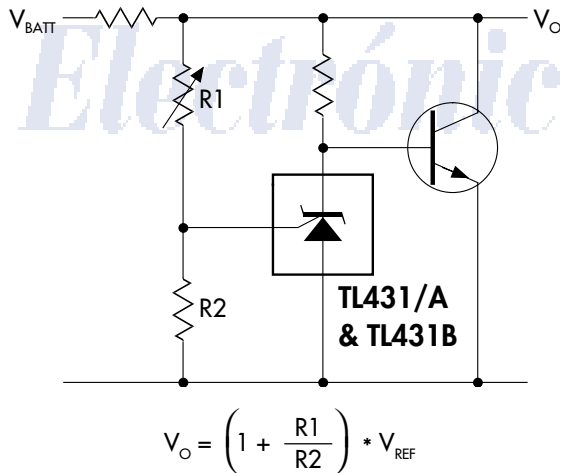
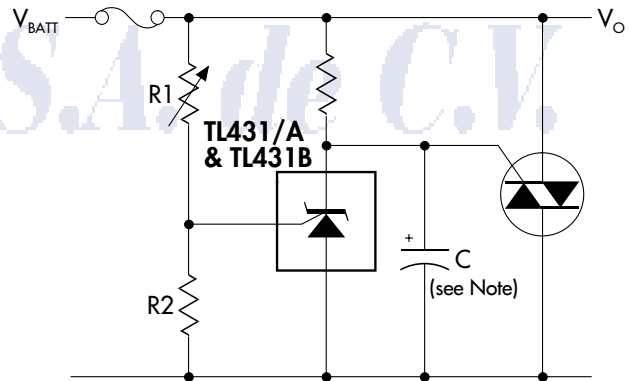

FIGURE 17 — SINGLE-SUPPLY COMPARATOR WITH TEMPERATURE-COMPENSATED THRESHOLD



$$V_o = \left(1 + \frac{R1}{R2}\right) * V_{REF}$$

FIGURE 18 — HIGH CURRENT SHUNT REGULATOR



Note: Refer to the stability boundary conditions in Figure 15 to determine allowable values for C.

FIGURE 19 — CROWBAR CIRCUIT

TL431/TL431A/TL431B

PRECISION PROGRAMMABLE REFERENCES

PRODUCTION DATA SHEET

APPLICATION INFORMATION

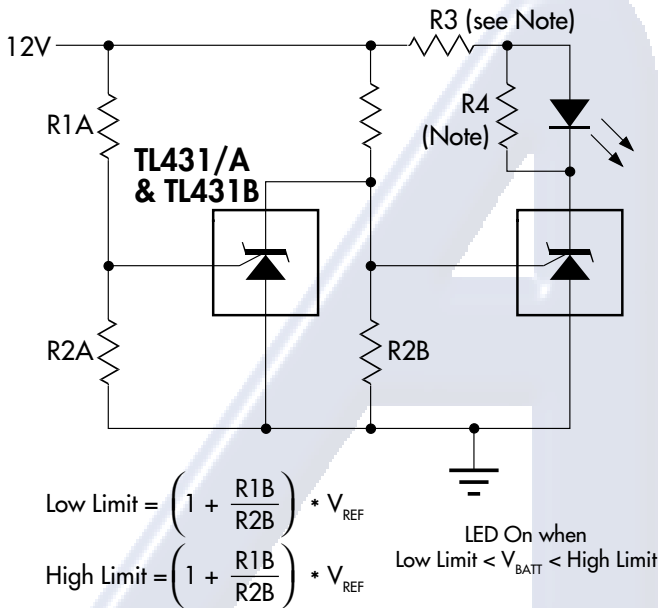

Note: R3 and R4 are selected to provide the desired LED intensity and ≥ 1 mA cathode current to the TL431/A & TL431B at the available V+.

FIGURE 20 — VOLTAGE MONITOR

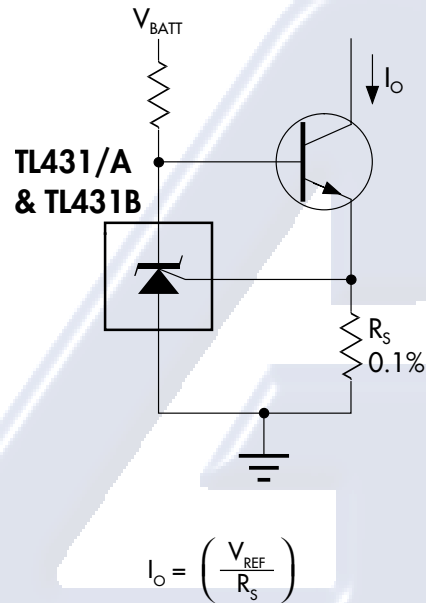

FIGURE 21 — PRECISION CONSTANT-CURRENT SINK

Electrónica S.A. de C.V.

PRODUCTION DATA - Information contained in this document is proprietary to Linfinity, and is current as of publication date. This document may not be modified in any way without the express written consent of Linfinity. Product processing does not necessarily include testing of all parameters. Linfinity reserves the right to change the configuration and performance of the product and to discontinue product at any time.

