



客户 CUSTOMER	工程编号 DESIGN NO	产品名称 DESCRIPTION	客户机型 YOUR MODEL NO	客户料号 YOUR PART NO	国家标准 STANDARD	版本 REV
加安电子	TRANS-12/1200	48型 电源变压器	**	EI48*26	**	A-0

二、电气特性:

ELECTRICITY CHARACTERISTIC:

1、初级输入电压及频率: AC 120V/60Hz

Primary Voltage and Frequency: AC 120V/60Hz

2、初级空载最大电流: $\leq 50\text{mA}$;

Exciting Current (unload): $\leq 50\text{mA}$;

3、在环境25°C下初级绕组直流电阻: ** Ω (+/-20%);

DC Resistance (+/-20%): **Ohm (at25°C)

4、次级\SECONDARY:

绕组 Team	引线(脚) Pin Lead NO	空载电压 $\pm 5\%$ Unload Voltage	负载电压 $\pm 5\%$ Load Voltage	额定电流 LoadCurrent	备注 Remark
1	蓝-黄-蓝	7VAC*2	6VAC*2	1200mA	

5、电气原理图:

SCHEMATIC DIAGRAM:

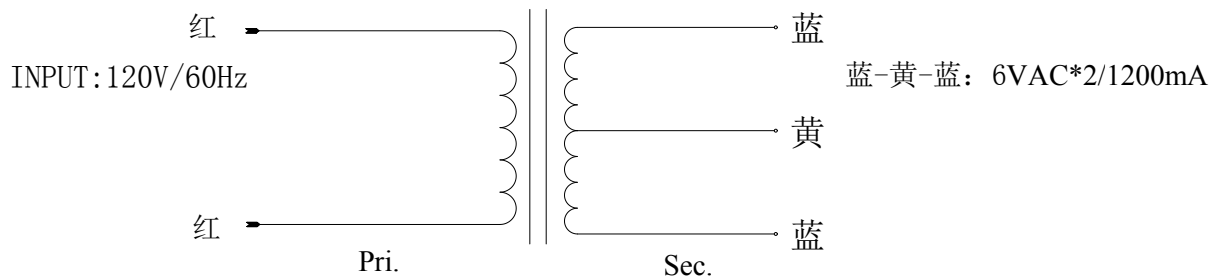

6、绝缘电阻: 初级对次、初级对铁芯承受直流500V电压要求绝缘电阻 $\geq 100\text{M}\Omega$ 。

INSULATION RESISTANCE: Pri.to Sec.and Core 100Mohm Min.For DC500V.

7、抗电强度: 初级对次、初级对铁芯1分钟内承受交流2KV电压要求漏电流 $< 3\text{mA}$ 。

DIELECTRIC STRENGTH: Pri.to Sec.and Core AC2KV ,3mA for One Minute.

8、绝缘等级: CLASS B

INSULATION CLASSIFICATION: CLASS B



客户 CUSTOMER	工程编号 DESIGN NO	产品名称 DESCRIPTION	客户机型 YOUR MODEL NO	客户料号 YOUR PART NO	国家标准 STANDARD	版本 REV
加安电子	TRANS-12/1200	48型 电源变压器	**	EI48*26	**	A-0

三、外观尺寸图:

(单位: mm)

EXTERNAL DIMENSION:

(Unit in mm)

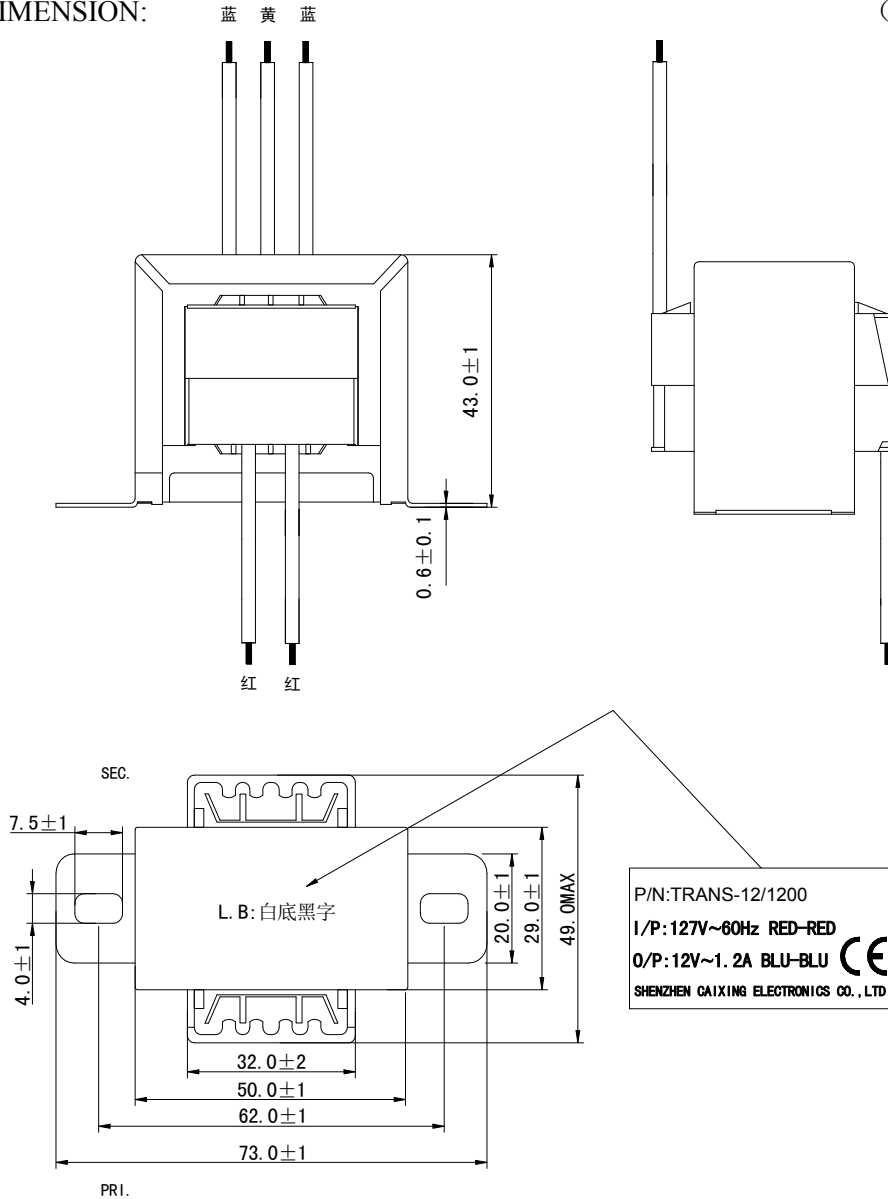

项目 Item	引线 Pin Leads Disposal	引线型号 Leads type	引线外露尺寸 Leads dimension	开口尺寸 Shell dimension	备注 Remark
初级	红-红	1672/22AWG	170mm-/+10mm	5mm-/+0mm	
次级	蓝-黄-蓝	1015/22AWG	170mm-/+10mm	5mm-/+0mm	



客户 CUSTOMER	工程编号 DESIGN NO	产品名称 DESCRIPTION	客户机型 YOUR MODEL NO	客户料号 YOUR PART NO	国家标准 STANDARD	版本 REV
加安电子	TRANS-12/1200	48型 电源变压器	**	EI48*26	**	A-0

四、测试报告：
TEST REPORT:

INPUT: AC 120 V 60 Hz Room Temperature: 25°C

	ITEM	PIN.LEAD	SPEC.	SPL1	SPL2	SPL3	SPL4	SPL5	SPL6
PRI	I ₀ (mA)MAX	红-红	≤50mA	33					
	P ₀ (W)								
	I _L (mA)								
	P _L (W)								

SEC	V ₀ (VAC)	蓝-黄-蓝	7VAC*2±5%	7.19					
	VL(VAC) @1200mA	蓝-黄-蓝	6VAC*2±5%	6.12					

SEC	V ₀ (VAC)								
	VL(VAC) @								

SEC	V ₀ (VAC)								
	VL(VAC) @								

SEC	V ₀ (VAC)								
	VL(VAC) @								

Visual Examination	OK								
Construction Examination	OK								
Polarity	**								

Hi-pot Test

Pri. to Sec.	2.0KV 3mA 1Minute	OK							
Pri. to Core	2.0KV 3mA 1Minute	OK							
Sec. to Core	0.50KV 3mA 1Minute	OK							

REMARKS:	DETERMINANT: Accept: <input type="checkbox"/> Rejection: <input type="checkbox"/>
----------	---

TEST BY 罗四海

APPROVED BY: