

# 产品规格书

## PRODUCT SPECIFICATIONS

料号Part NO		02-002				
产品名称Product Name		TRIMER-5PF; TRIMER-50PF; TRIMER-60PF				
型号Model No		HK06-1				
容量范围 (PF) Cop Honge						
		标称容量 (PF) Nominal Copacitance (PF)	容量误差 Capacitance tolerance	电容温度系数 Camp coeff (ppa/°C)	Q值 Q VOLUE	备注 Remarks
最小值min	最大值max					
Less than 1.8	3	<input type="checkbox"/> 06-3P	3+100% - 0%	NPO±250	> 500	Black
2.4	5	<input type="checkbox"/> 06-5P	5+100% -0%			Blue
2.8	7	<input type="checkbox"/> 06-7P	7+100% -0%			Blue
3.8	10	<input type="checkbox"/> 06-10P	10+100% -0%	N450±300		White
6.5	20	<input type="checkbox"/> 06-20P	20+100% -0%	N750±300		Red
9	30	<input type="checkbox"/> 06-30P	30+100% -0%	N1000±500		Green
12	40	<input type="checkbox"/> 06-40P	40+100% -0%	N2200±800		>300
17	50	<input type="checkbox"/> 06-50P	50+100% -0%		>200	Brown
22	60	<input type="checkbox"/> 06-60P	60+100% -0%			Brown
28	70	<input type="checkbox"/> 06-70P	70+100% -0%			Brown
38	120	<input checked="" type="checkbox"/> 06-120P	120+100% -0%			Brown
额定电压Rated Voltage:			100V			
最大电压Max Voltage:			220V			
绝缘电阻Insulation Resistance:			10000MΩ			
工作环境温度 Operating Temperature:			-25~85°C			

D

C

B

A

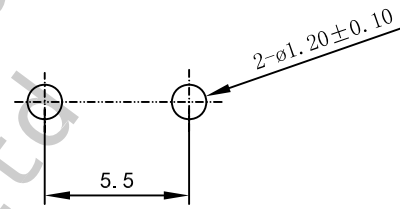
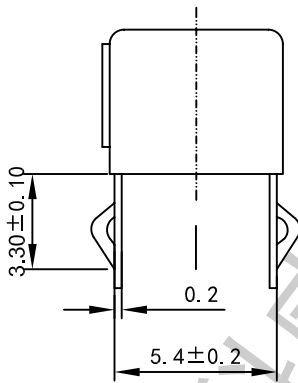
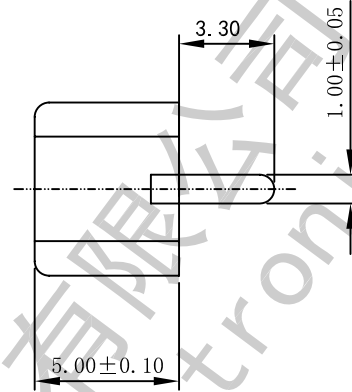
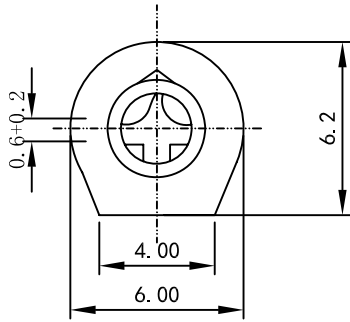

			8	料号 PART NO.	02-002	未注公差 TOLERANCE	
			7	型号 MODEL	HK06-1	1~10	±0.30
			6	品名 ARTICLE	可调电容	10~50	±0.40
			5	单位 UNIT	mm	50~100	±0.50
			4	比例 SCALE	4:1	ANGLE	±5°
			3	批准 APPRO.	审核 CHECK	制图 DRAW	PROJECTION 视图方法
			2	向明根	吕新权	张作虎	
			1				
更版标记 REVISION NOTE	承认 APPRO.	日期 DATE	NO.	<b>深圳市华科威视电子科技有限公司</b> Shenzhen Huakevision Electronic Technology Co., Ltd			

D

C

B

A