

Description

The μ PD8255A-2 and μ PD8255A-5 are general purpose programmable input/output devices designed for use with the 8080A/8085A microprocessors. Twenty-four I/O lines may be programmed in two groups of twelve (group I and group II) and used in three modes of operation. In the basic mode, (Mode 0), each group of twelve I/O pins may be programmed in sets of 4 to input or output. In the strobed mode, (MODE 1), each group may be programmed to have 8 lines of input or output. Three of the remaining four pins in each group are used for handshaking strobes and interrupt control signals. The bidirectional bus mode, (MODE 2), uses the 8 lines of port A for a bi-directional bus, and five lines from port C for bus control signals.

Features

- Fully compatible with the 8080A/8085 microprocessor families
- All inputs and outputs TTL compatible
- 24 programmable I/O pins
- Direct bit set/reset eases control application interfaces
- Eight Darlington drive outputs for printers and displays
- LSI drastically reduces system package count

Ordering Information

Part Number	Package Type	Max System Clock Frequency
μ PD8255AC-2	40-pin plastic DIP	5 MHz
μ PD8255AC-5	40-pin plastic DIP	4 MHz

Pin Configuration

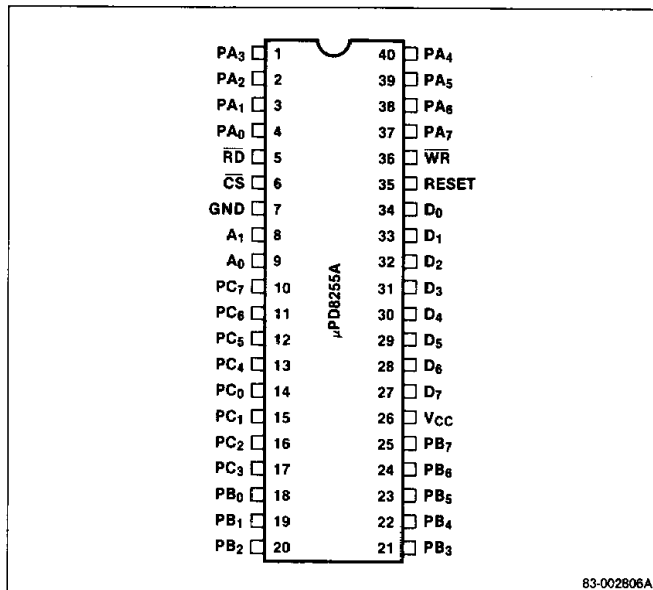

83-002806A

Pin Identification

No.	Symbol	Function
1-4, 37-40	PA ₇ -PA ₀	Port A (I/O)
5	\overline{RD}	Read input
6	\overline{CS}	Chip select input
7	GND	Ground
8,9	A ₁ , A ₀	Port address inputs
10-17	PC ₇ -PC ₀	Port C (I/O)
18-25	PB ₇ -PB ₀	Port B (I/O)
26	V _{CC}	+5 V power supply
27-34	D ₇ -D ₀	Bidirectional data bus
35	RESET	Reset input
36	\overline{WR}	Write input

μPD8255A

Pin Functions

D₇-D₀ (Data Bus Buffer)

These pins form a three-state, bidirectional data bus buffer that is controlled by input and output instructions executed by the processor. Control words and status information are also transmitted via D₇-D₀.

\overline{CS} (Chip Select)

A low input to this pin enables the μPD8255A for communication with the 8080A/8085A.

\overline{RD} (Read)

A low input to this pin enables the μPD8255A for communication with the 8080A/8085A.

\overline{WR} (Write)

A low input to this pin enables the data bus buffer to receive data or control words from the processor.

A₁, A₀ (Port Address)

These inputs are used in conjunction with \overline{CS} , \overline{RD} , and \overline{WR} to control the selection of one of the three ports on the control word register. A₀ and A₁ are usually connected to A₀ and A₁ of the processor address bus.

RESET (Reset)

A high level input to this pin clears the control register and places ports A, B, and C in input mode. The input latches in ports A, B, and C are not cleared.

PA₇-PA₀, PB₇-PB₀, PC₇-PC₀ (Ports A, B, and C)

These three 8-bit I/O ports can be configured to meet a variety of functional requirements through system software. The effectiveness and flexibility of the μPD8255A are further enhanced by special features unique to each of the ports, as follows:

- Port A has an 8-bit data output latch/buffer, data input latch/buffer, and data input latch.
- Port B has an 8-bit data I/O latch/buffer and an 8-bit data input buffer.
- Port C has an 8-bit output latch/buffer and a data input buffer (input not latched).

Port C may be divided into two independent 4-bit control and status ports for use with ports A and B.

V_{CC}

+5 V power supply.

GND (Ground)

Connection to ground.

Block Diagram

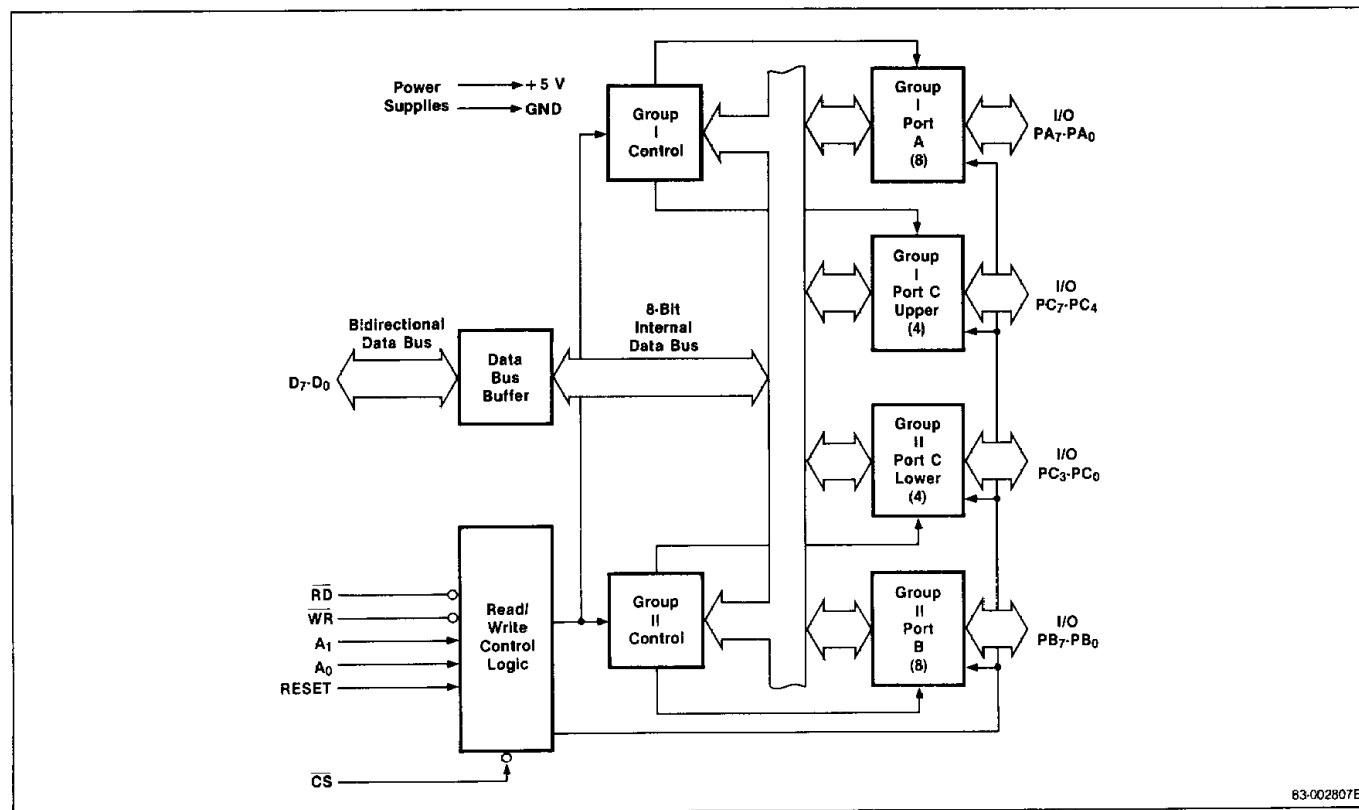

Functional Description

The read/write and control logic manages all internal and external transfers of data, control, and status. It is through this block that the processor address and control buses control the peripheral interfaces.

Through an OUT instruction in system software from the processor, a control word is transmitted to the μPD8255A. Information such as the mode, bit set, and bit reset is used to initialize the functional configuration of each I/O port.

Both group I and group II accept commands from the read/write control logic and control words from the internal data bus and in turn controls its associated I/O ports, as follows:

- Group I: port A and upper port C (PC₇-PC₄)
- Group II: port B and lower port C (PC₃-PC₀)

While the control word register can be written to, the contents cannot be read back to the processor.

Absolute Maximum Ratings

T_A = 25°C

Operating temperature, T _{OPT}	0°C to +70°C
Storage temperature, T _{STG}	-65°C to +150°C
Voltage on any pin with respect to V _{SS}	-0.5 to +7 V

Comment: Stresses above those listed under Absolute Maximum Ratings may cause permanent damage to the device. This is a stress rating only and functional operation of the device at these or any other conditions above those indicated in the operational sections of this specification is not implied. Exposure to absolute maximum rating conditions for extended periods may affect device reliability.

DC Characteristics

T_A = 0 to +70°C; V_{CC} = +5 V ±10%; V_{SS} = 0 V

Parameter	Symbol	Limits		Unit	Test Conditions
		Min	Max		
Input low voltage	V _{IL}	-0.5	0.8	V	
Input high voltage	V _{IH}	2	V _{CC}	V	
Output low voltage	V _{OL}		0.45	V	(2)
Output high voltage	V _{OH}	2.4		V	(3)
Darlington drive current	I _{OH} (1)	-1	-4	mA	V _{EXT} = 1.5 V R _{EXT} = 750Ω
Power supply current	I _{CC}		120	mA	V _{CC} = +5 V, output open
Input leakage current	I _{LIH}		10	μA	V _{IN} = V = V _{CC}
Input leakage current	I _{LIL}		-10	μA	V _{IN} = 0.4 V
Output leakage current	I _{LOH}		±10	μA	V _{OUT} = V _{CC} ; CS = 2.0 V
Output leakage current	I _{LOL}		-10	μA	V _{OUT} = 0.4 V; CS = 2.0 V

Note:

- (1) Any set of eight outputs from either port A, B, C can source 4 mA into 1.5 V.
- (2) I_{OL} = 2.5 mA for DB port; 1.7 mA for peripheral ports.
- (3) I_{OH} = -400μA for DB port; -200 μA for peripheral ports.

Capacitance

T_A = 25°C; V_{CC} = 0V

Parameter	Symbol	Limits		Unit	Test Conditions
		Min	Max		
Input capacitance	C _I		10	pF	f _c = 1 MHz
I/O capacitance	C _{IO}		20	pF	Unmeasured pins returned to V _{SS}

μPD8255A

AC Characteristics

$T_A = 0^\circ\text{C to } +70^\circ\text{C}; V_{CC} = +5\text{ V } \pm 5\%; V_{SS} = 0\text{ V}$

Parameter	Symbol	8255A-2 Limits		8255A-5 Limits		Unit	Test Conditions
		Min	Max	Min	Max		
Address stable before $\overline{\text{READ}}$	t_{AR}	0		0		ns	
Address stable after $\overline{\text{READ}}$	t_{RA}	0		0		ns	
$\overline{\text{READ}}$ pulse width	t_{RR}	200		250		ns	
Data valid from $\overline{\text{READ}}$	t_{RD}		140		170	ns	$C_L = 150\text{ pF}$
Data float after $\overline{\text{READ}}$	t_{DF}	10	100	10	100	ns	$C_L = 100\text{ pF}$ $C_L = 15\text{ pF}$
Time between $\overline{\text{READS}}$ and $\overline{\text{WRITES}}$	t_{RV}	200		850		ns	(Note 2)
Write							
Address stable before $\overline{\text{WRITE}}$	t_{AW}	0		0		ns	
Address stable after $\overline{\text{WRITE}}$	t_{WA}	20		20		ns	
$\overline{\text{WRITE}}$ pulse width	t_{WW}	200		250		ns	
Data valid to $\overline{\text{WRITE}}$ (T.E.)	t_{DW}	100		100		ns	
Data valid after $\overline{\text{WRITE}}$	t_{WD}	0		0		ns	
Other Timing							
$\overline{\text{WR}} = 0$ to output	t_{WB}		350		350	ns	$C_L = 150\text{ pF}$
Peripheral data before $\overline{\text{RD}}$	t_{IR}	0		0		ns	
Peripheral data after $\overline{\text{RD}}$	t_{HR}	0		0		ns	
$\overline{\text{ACK}}$ pulse width	t_{AK}	300		300		ns	
$\overline{\text{STB}}$ pulse width	t_{ST}	350		350		ns	
Per. data before T.E. of $\overline{\text{STB}}$	t_{PS}	0		0		ns	
Per. data after T.E. of $\overline{\text{STB}}$	t_{PH}	150		150		ns	
$\overline{\text{ACK}} = 0$ to output	t_{AD}		300		300	ns	$C_L = 150\text{ pF}$
$\overline{\text{ACK}} = 0$ to output float	t_{KD}	20	250	20	250	ns	$C_L = 50\text{ pF}$ $C_L = 15\text{ pF}$
$\overline{\text{WR}} = 1$ to $\text{OBF} = 0$	t_{WOB}		300		650	ns	
$\overline{\text{ACK}} = 0$ to $\text{OBF} = 1$	t_{AOB}		350		350	ns	
$\overline{\text{STB}} = 0$ to $\text{IBF} = 1$	t_{SIB}		300		300	ns	
$\overline{\text{RD}} = 1$ to $\text{IBF} = 0$	t_{RIB}		300		300	ns	
$\overline{\text{RD}} = 0$ to $\text{INTR} = 0$	t_{RIT}		400		400	ns	
$\overline{\text{STB}} = 1$ to $\text{INTR} = 1$	t_{SIT}		300		300	ns	$C_L = 150\text{ pF}$
$\overline{\text{ACK}} = 1$ to $\text{INTR} = 1$	t_{AIT}		350		350	ns	
$\overline{\text{WR}} = 0$ to $\text{INTR} = 0$	t_{WIT}		450		850	ns	$C_L = 150\text{ pF}$ (Note 3)

Note:

(1) Period of reset pulse must be at least 50 μs during or after power on. Subsequent reset pulse can be 500 ns min.

(2)

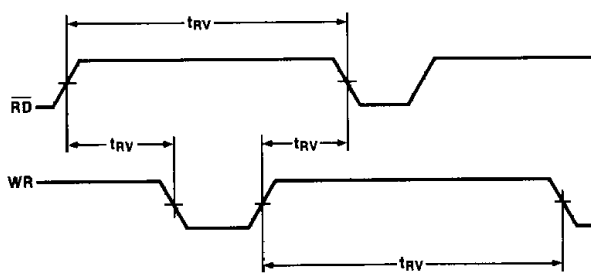

(3) $\text{INTR}\uparrow$ may occur as early as $\overline{\text{WR}}\downarrow$.

AC Testing Load Circuit

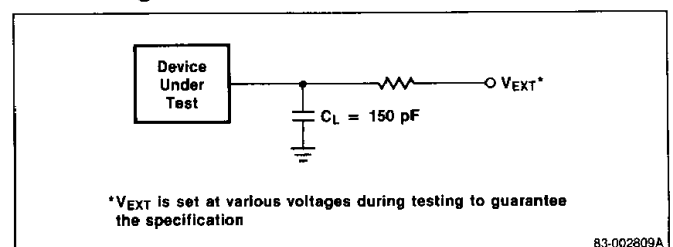

Timing Waveforms

AC Testing Input, Output Waveform

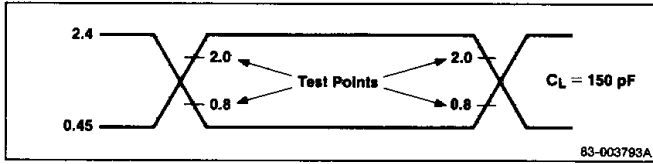

Mode 0

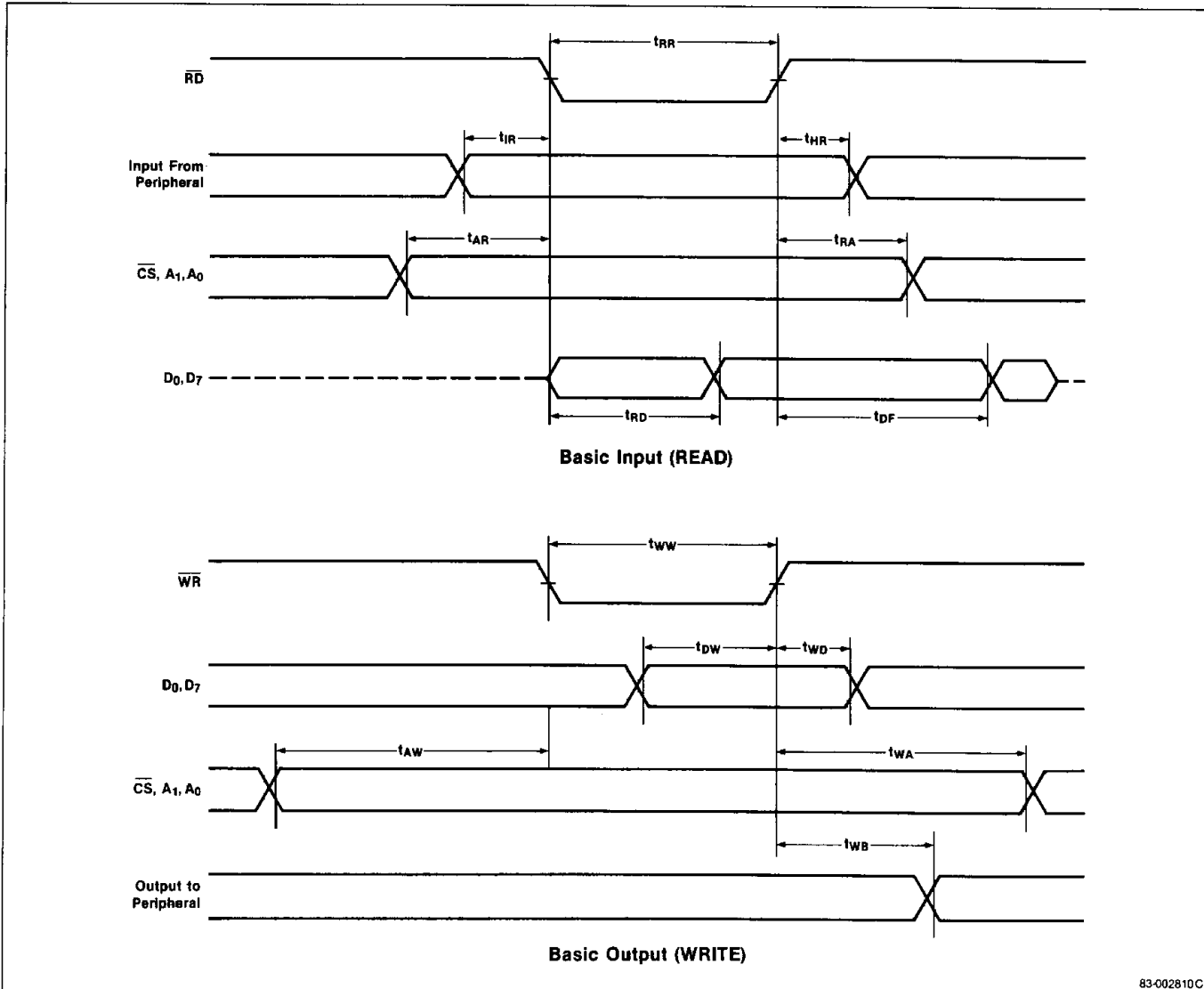

μ PD8255A

Timing Waveforms (cont)

Mode 1

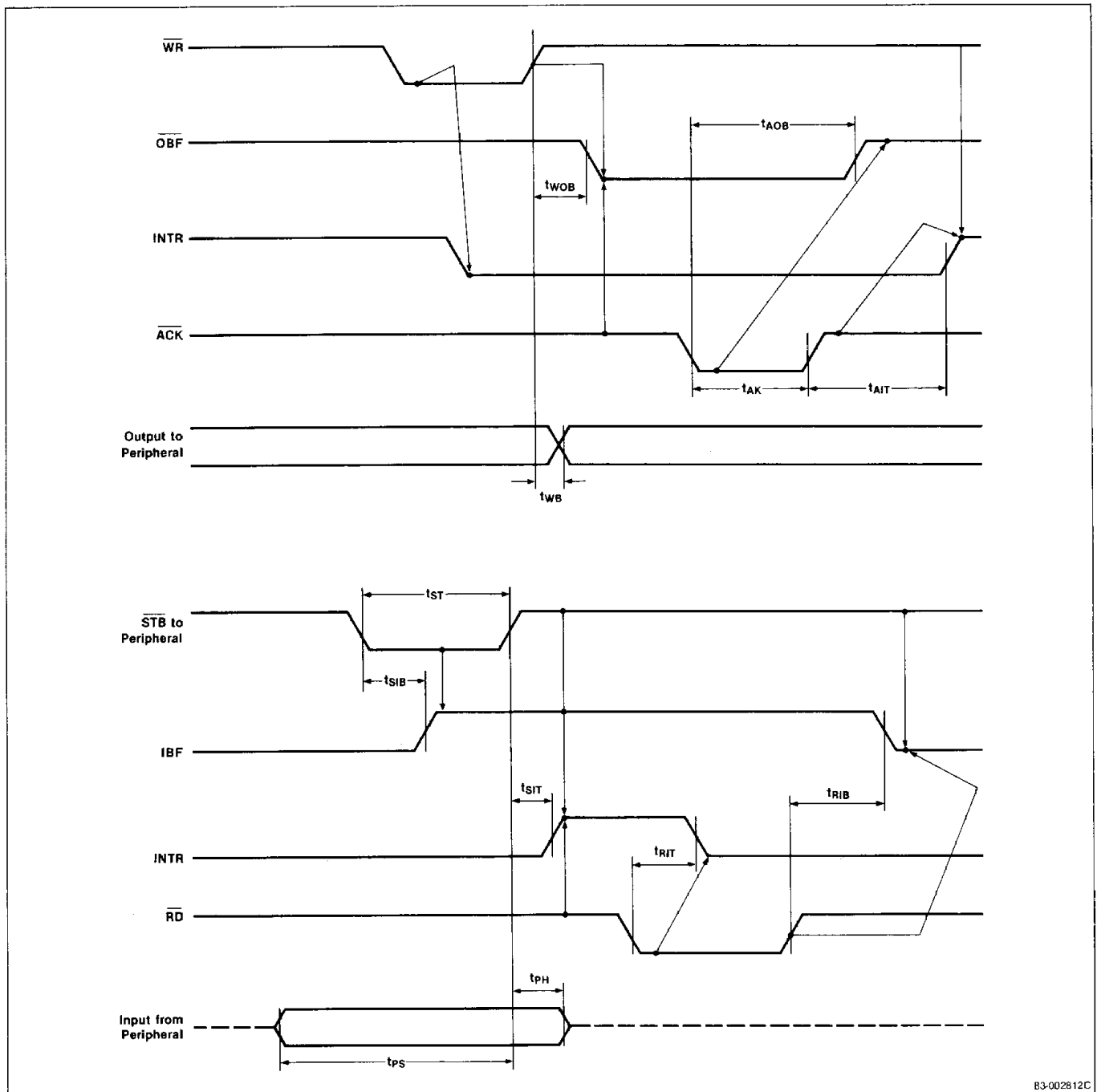

B3-002812C

Timing Waveforms (cont)

Mode 2

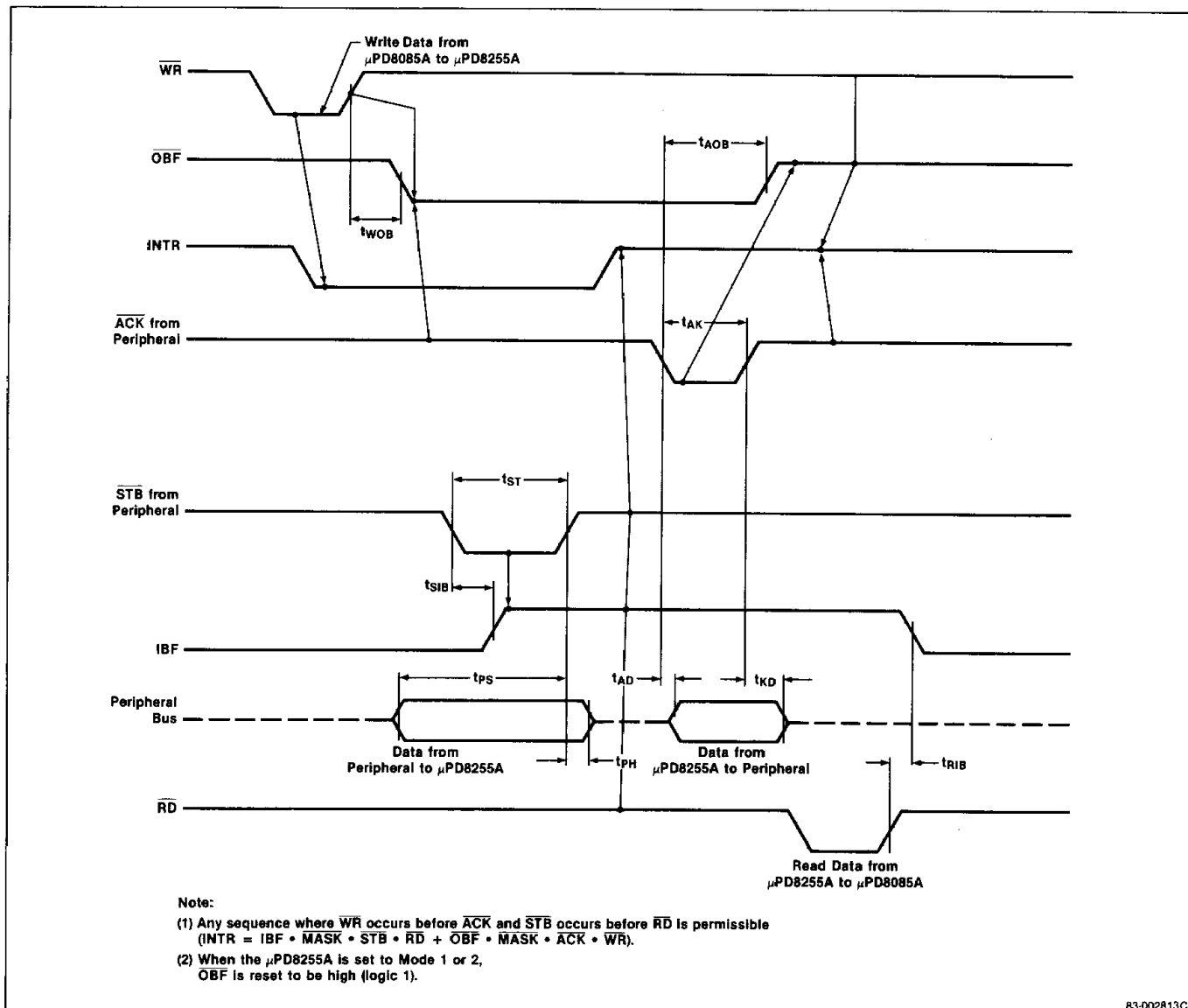

83-002813C



μPD8255A

Modes

The μPD8255A can be operated in modes 0, 1 or 2 which are selected by appropriate control words and are detailed below.

Mode 0

Mode 0 provides basic input and output operations through each of the ports A, B, and C. Output data is latched and input data follows the peripheral. No “handshaking” strobes are needed.

- 16 different configurations in mode 0
- Two 8-bit ports and two 4-bit ports
- Inputs are not latched
- Outputs are latched

Mode 1

Mode 1 provides for strobed input and output operations with data transferred through port A or B and handshaking through port C.

- Two I/O groups (I and II)
- Both groups contain an 8-bit data port and a 4-bit control/data port
- Both 8-bit data ports can be either latched input or latched output

Mode 2

Mode 2 provides for strobed bidirectional operation using PA₀PA₇ as the bidirectional latched data bus. PC₃PC₇ is used for interrupts and “handshaking” bus flow control similar to mode 1. Note that PB₀PB₇ and PC₀PC₂ may be defined as mode 0 or 1, input or output in conjunction with port A in mode 2.

- An 8-bit latched bidirectional bus port (PA₀-PA₇) and a 5-bit control port (PC₃PC₇)
- Both inputs and outputs are latched
- An additional 8-bit input or output port with a 3-bit control port.

Basic Operation

Input Operation (Read)

A ₁	A ₀	RD	WR	CS	
0	0	0	1	0	PORT A → DATA BUS
0	1	0	1	0	PORT B → DATA BUS
1	0	0	1	0	PORT C → DATA BUS

Output Operation (Write)

A ₁	A ₀	RD	WR	CS	
0	0	1	0	0	DATA BUS → PORT A
0	1	1	0	0	DATA BUS → PORT B
1	0	1	0	0	DATA BUS → PORT C
1	1	1	0	0	DATA BUS → CONTROL

Disable Function

A ₁	A ₀	RD	WR	CS	
X	X	X	X	1	DATA BUS → HIGH Z STATE
X	X	1	1	0	DATA BUS → HIGH Z STATE

Note:

- (1) X means “DO NOT CARE”
- (2) All conditions not listed are illegal and should be avoided.



Formats

Mode Definition, Bit/Rest Format

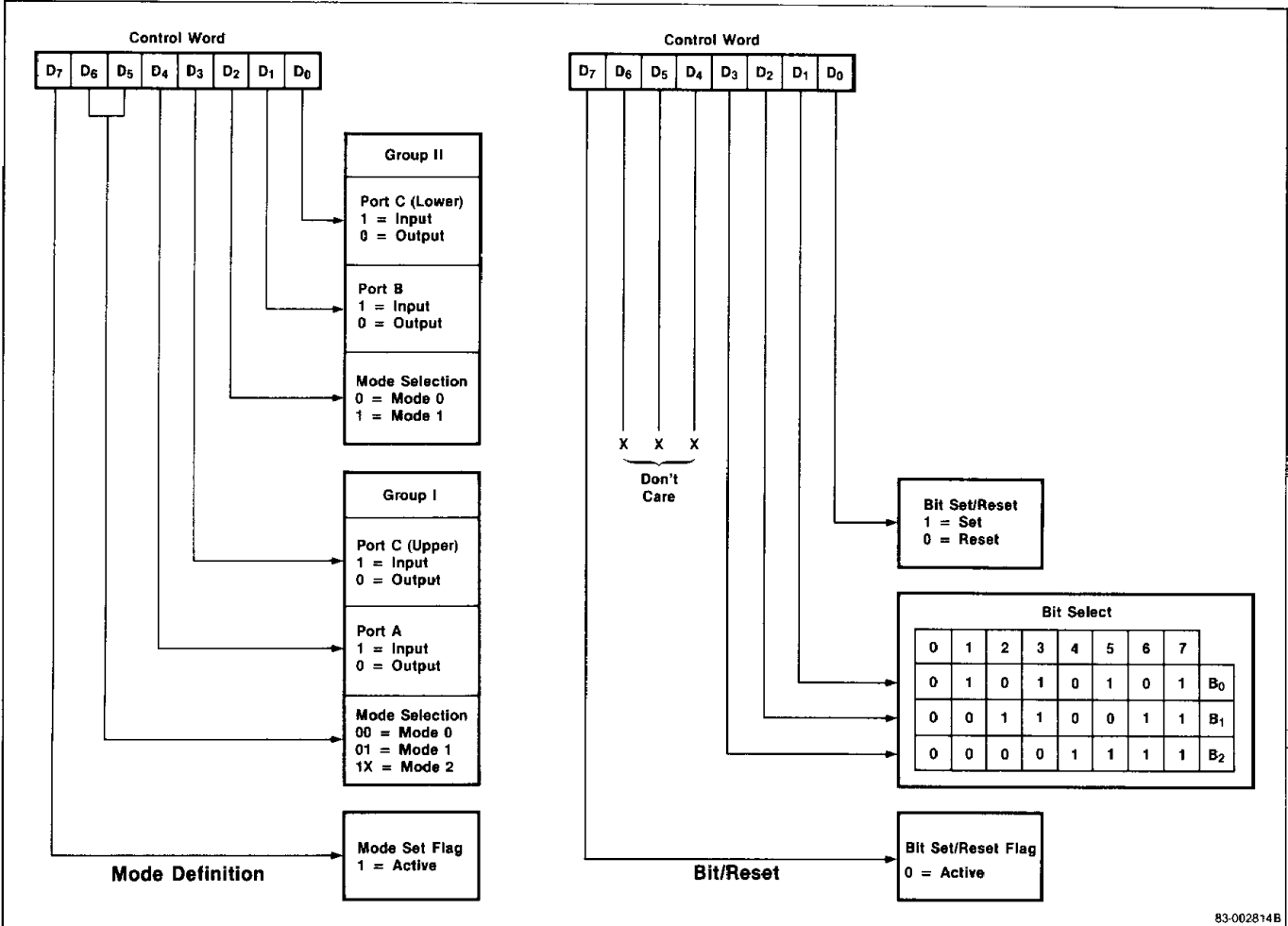

83-002814B