

VGT10SEE-200S2A5

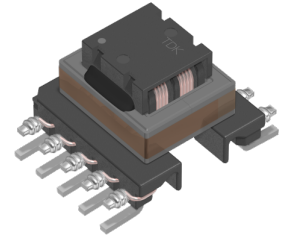

<b>Applications</b>	Automotive
<b>Functions</b>	Flyback transformer (Distributed)
<b>Series</b>	VGT
<b>Status</b>	 Preliminary
<b>Brand</b>	TDK



#### Size

Length(L)	13.00mm ±0.30mm
Width(W)	17.40mm ±0.50mm
Thickness(T)	10.80mm Max.

#### Electrical Characteristics

Turns Ratio	1:1:1:1
Number of Output	2
Inductance	20μH ±25%
Leakage Inductance [Max.]	500nH
Withstanding Voltage [Pri-Sec]	2.6kVrms 1min. or 3.2kVrms 1sec.
Withstanding Voltage [Coil-Core]	1.3kVrms 1min. or 1.6kVrms 1sec.

#### Other

Operating Temp. Range	-40 to 130°C
AEC-Q200	Yes
Packing	Embossed (Plastic)Taping [330mm Reel, Tape width 32mm]
Package Quantity	250pcs
Weight	1.9g

VGT10SEE-200S2A5



## Associated Images

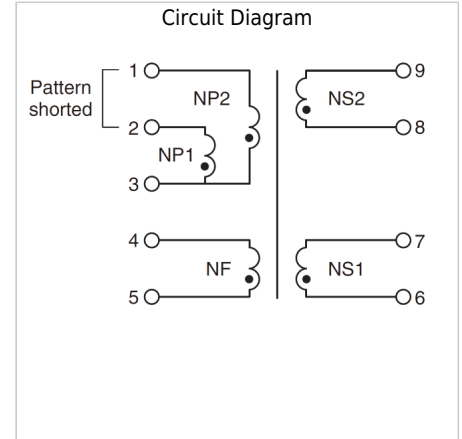
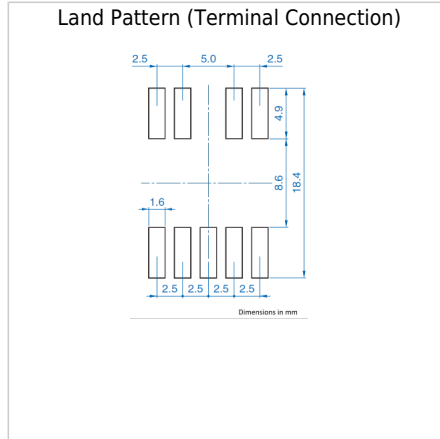
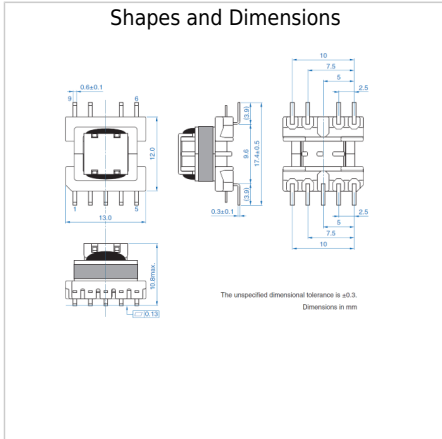

! Images are for reference only and show exemplary products.  
! This PDF document was created based on the data listed on the TDK Corporation website.  
! All specifications are subject to change without notice.